

Onan *Mobile GenSet*

Service Manual

HGJAA, HGJAB, HGJAC,
HGJAD, HGJAE, HGJAF

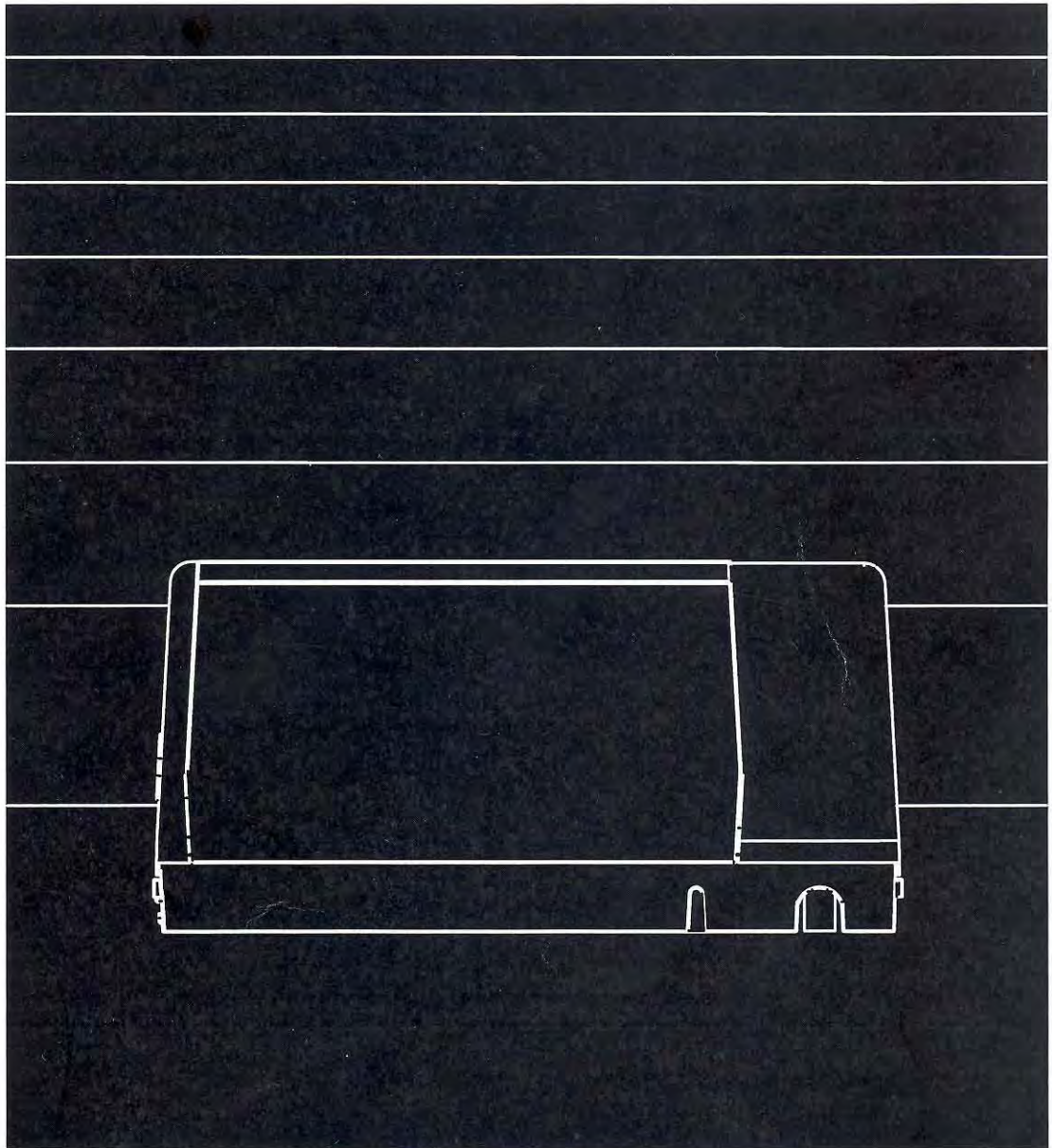



WARNING:



The engine exhaust from this product contains chemicals known to the State of California to cause cancer, birth defects or other reproductive harm.



WARNING



**Do not use this genset on a boat
Such use may violate U. S. Coast Guard
regulations and can result in
severe personal injury or death from
fire, electrocution, or
carbon monoxide poisoning**

Table of Contents

Part 1

SECTION	PAGE
SAFETY PRECAUTIONS	v
1. INTRODUCTION	1-1
2. OPERATION	2-1
Fuel Recommendations	2-1
Engine Oil Recommendations	2-1
Starting Batteries	2-1
Genset Control Panel	2-2
Remote Control Panel	2-2
Conducting Pre-Start Checks	2-3
Priming Gasoline Fuel Systems	2-3
Starting the Genset	2-3
Stopping the Genset	2-4
Restarting the Genset	2-4
Engine Only Operation	2-4
Genset Lockout Switch	2-4
3. PERIODIC MAINTENANCE	3-1
Conducting General Inspections	3-2
Checking Engine Oil Level	3-3
Changing Engine Oil and Oil Filter	3-4
Maintaining Battery and Battery Connections	3-5
Replacing the Air Filter Element	3-5
Replacing Spark Plugs	3-6
Cleaning the Spark Arrestor	3-7
4. PREPARING FOR SERVICE	4-1
Troubleshooting	4-1
Safety	4-1
Special Tools	4-1
Removing the Genset	4-2
Installing the Genset	4-3

SECTION	PAGE
5. CONTROL	5-1
Controller A1	5-1
Other Control Components	5-4
6. GENERATOR	6-1
Generator Description	6-1
Generator Service	6-1
Brushes and Slip Rings	6-3
Generator Testing	6-4
Voltage Adjustments—HGJAD, HGJAE, HGJAF	6-5
Generator Connections	6-5
7. FAN, DRIVE BELT, FLYWHEEL, IGNITION, EXHAUST	7-1
Fan, Belt, Pulleys and Flywheel	7-1
Ignition System	7-4
Exhaust System	7-6
8. FUEL SYSTEM	8-1
Gasoline Fuel System—HGJAA & HGJAD	8-1
Gasoline Fuel System—HGJAB, HGJAC, HGJAE, HGJAF	8-8
LPG Fuel System—HGJAB, HGJAC, HGJAE, HGJAF	8-13
Mechanical Governor—HGJAB, HGJAC, HGJAE, HGJAF	8-19
<hr style="border: 1px solid red;"/>	
9. ENGINE	9-1
Testing Compression / Leakdown	9-1
Testing Crankcase Vacuum	9-1
Removing and Installing Generator / Engine Assembly	9-1
Removing and Installing Engine	9-3
Starter Motor	9-3
Adjusting Valve Lash	9-4
Cylinder Heads and Valves	9-5
Crankcase Assembly	9-6
Dimensions and Clearances	9-15
10. HYDRAULIC PUMP	10-1
Installing the Hydraulic Pump	10-1
Connecting Hydraulic Hoses	10-1

SECTION	PAGE
11. TROUBLESHOOTING	11-1
Fault Codes	11-1
Genset Starts or Stops Without Command – No Fault Code	11-2
No Response – Status Indicator Light Dead	11-3
Starting Batteries Run Down	11-3
Starter Engages – Disengages	11-4
No AC Power – Genset Running, Status LED On Steady or Flashing Rapidly .	11-4
Genset Cranks But Does Not Start – No Fault Code	11-5
Genset Runs But Stops When Switch Is Released – No Fault Code	11-5
Low Oil Pressure Fault – Fault Code 2	11-5
Service Check Fault – Fault Code 3	11-6
Overcrank – Fault Code 4	11-6
Overvoltage – Fault Code 12	11-8
Undervoltage – Fault Code 13	11-9
Overfrequency – Fault Code 14	11-10
Underfrequency – Fault Code 15	11-12
Fuel Pump Fault – Fault Code 17	11-14
Governor Actuator (EFI Only) – Fault Code 19	11-14
Governor Actuator Overload (EFI Only) – Fault Code 22	11-15
Oil Pressure Switch Fault – Fault Code 23	11-16
Voltage Sense Lost – Fault Code 27	11-16
High Battery Voltage – Fault Code 29	11-18
Overspeed Fault (HGJAD, E, F Models Only) – Fault Code 31	11-19
Low Cranking Speed Sense – Fault Code 32	11-21
Fault Code 33 – Fault Code 33	11-22
Control Card Failure – Fault Code 35	11-23
Genset Stopped Without Fault Condition – Fault Code 36	11-23
Invalid Set Configuration – Fault Code 37	11-25
Field Overload (Overvoltage) – Fault Code 38	11-26

SECTION	PAGE
11. TROUBLESHOOTING (CONT.)	11-28
Generator Rotor Fault – Fault Code 41	11-28
Processor Fault – Fault Code 42	11-29
Processor Fault – Fault Code 43	11-29
Speed Sense Fault – Fault Code 45	11-30
Ignition Fault – Fault Code 47	11-32
Field Sense Fault – Fault Code 48	11-33
Processor Failure – Fault Code 51	11-33
Fuel Injector Fault – Fault Code 52	11-33
MAT Sensor Fault – Fault Code 54	11-34
MAP Sensor Fault – Fault Code 56	11-34
Overprime Fault – Fault Code 57	11-35
12. SERVICE CHECKLIST	12-1
13. SPECIFICATIONS	13-1
14. TORQUE SPECIFICATIONS	14-1
WIRING DIAGRAM—HGJAA	A-1
WIRING HARNESS—HGJAA	A-2
WIRING DIAGRAM—HGJAB/HGJAC	A-3
WIRING HARNESS—HGJAB/HGJAC	A-4
WIRING DIAGRAM—HGJAD	A-5
WIRING HARNESS—HGJAD	A-6
WIRING DIAGRAM—HGJAE & HGJAF	A-7
WIRING HARNESS—HGJAE & HDJAF	A-8

9. Engine

TESTING COMPRESSION / LEAKDOWN

Test engine compression and / or leakdown to confirm whether the engine is worn. Compression should fall between 153 and 188 psi and not vary between cylinders by more than 10 percent.

TESTING CRANKCASE VACUUM

Test crankcase vacuum to confirm whether the engine is worn or the breather valve is malfunctioning. Vacuum should be 7 to 10 inches of water column as measured through a tap in the oil fill cap.

REMOVING AND INSTALLING GENERATOR / ENGINE ASSEMBLY

Figure 9-1 illustrates how the engine is mounted on the generator/engine base. The flywheel, exhaust manifold and mounting bolts are accessible for removal on the bottom side of the base.

Removal

Remove the generator/engine assembly from the genset, and then the engine, drive belt, exhaust manifold or ignition coils (magnetos) from the generator/engine assembly.

1. Drain the engine oil because the genset will be turned on its side to remove components.
2. Remove the two-piece control enclosure (Section 5. *Control*) and disconnect the AC output leads from their terminals on the circuit breakers and base.
3. Disconnect the grounding strap at the generator/engine base.
4. Disconnect fuel pump or fuel solenoid leads.
5. Disconnect the fuel lines at the engine (at the fuel filter outlet [supply] and pressure regulator

[return] on EFI models, or at the carburetor or LPG regulator on other models).

6. For Models HGJAA, HGJAB, HGJAD and HGJAE disconnect the engine exhaust outlet at the muffler flange and remove the heat shield between the muffler and engine. For Models HGJAC and HGJAF, remove the muffler.
7. If the engine is to be separated from the base, disconnect all wiring from the engine:
 - A. Spark plug cables (two)
 - B. Ignition kill (two)
 - C. Starter motor and solenoid
 - D. Low oil pressure cutoff switch
 - E. On EFI models, the governor actuator, fuel injector and MAP and MAT sensors, and on models with carburetors, the choke heater and fuel cutoff.
8. If the engine is to be separated from the base, remove the generator/engine bracket and loosen or remove the cylinder shroud screws.

⚠ CAUTION *1) To prevent possible damage, do not rest the generator/engine assembly on its fan shroud. 2) Place blocks under the assembly when it is rested upside-down so that the weight will not bear on the choke pulloff diaphragm (gasoline carburetors).*

9. Remove the two fail-safe bolts. With assistance, lift the generator/engine assembly off its four mounting springs and rest it upside-down. (Four 3/8–16 holes, one in each corner, are provided for lifting and support.)

Installation

Installation is the reverse of removal. Torque the fail-safe bolts to 38 lb-ft (51 N-m). Check that the assembly floats freely on its springs and does not make contact with the drip pan.

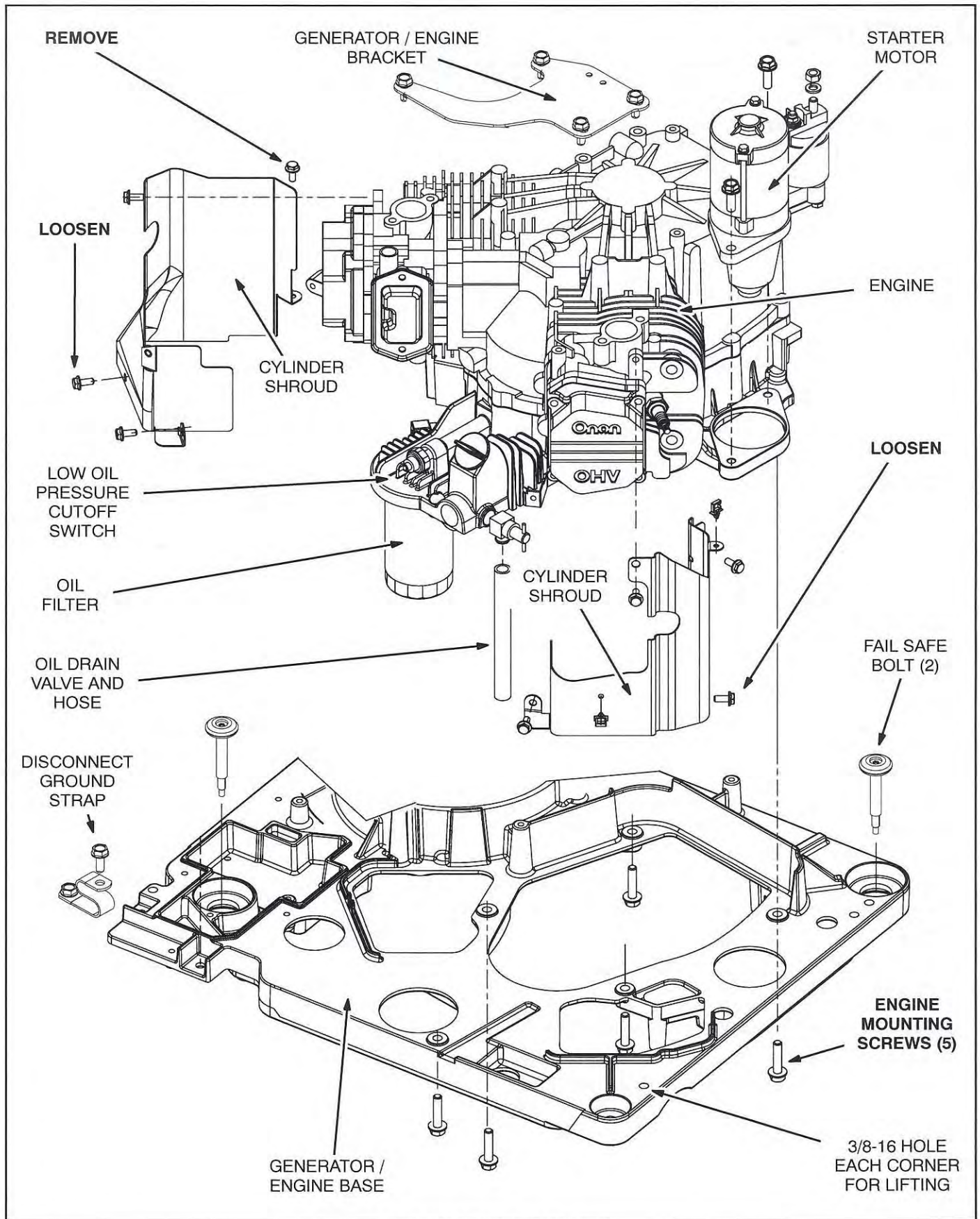

FIGURE 9-1. ENGINE

REMOVING AND INSTALLING ENGINE

Removal

1. Unless it has already been performed, disconnect all wiring from the engine, remove the generator/engine bracket and loosen or remove the cylinder shroud screws shown in Figure 9-1.
2. Remove the ignition coils, flywheel and exhaust manifold (Section 7. *Fan, Drive Belt, Flywheel, Ignition, Exhaust*).
3. Remove the five screws securing the engine to the generator/engine base and lift off the base.

Installation

Installation is the reverse of removal. Torque the engine mounting screws to 20 lb-ft (27 N-m). Torque the cylinder shroud screws to 8 lb-ft (11 N-m).

STARTER MOTOR

Replacing Starter Motor

To remove the starter motor (Figure 9-1), disconnect all wiring and remove the two mounting screws. Follow instructions in the starter motor kit if the starter is to be repaired. When installing a starter motor, torque the mounting screws to 20 lb-ft (27 N-m) and the terminal nut to 6.5 lb ft (8 N-m).

Replacing Starter Motor Solenoid

The starter solenoid is separately replaceable. To determine whether the problem is in the solenoid or in the motor:

⚠WARNING *This test involves high electrical currents, strong arcing and moving parts that can cause severe personal injury. Do not conduct this test near fuel tanks or when flammable vapors are present. Wear safety glasses. Keep fingers away from the pinion gear.*

1. Secure the motor assembly in a vice after it has been removed from the genset.
2. Using a heavy jumper cable, because of the large currents involved, connect the motor terminal on the solenoid (the one closest to the motor) to the positive (+) terminal on a 12 volt battery.
3. Using a heavy cable from the negative (–) terminal on the battery, briefly touch the mounting flange on the motor.
 - A. *If the motor does not spin up quickly and smoothly*, replace the motor/solenoid assembly.
 - B. *If the motor does spin up quickly and smoothly*, the motor is probably okay: replace the solenoid.
 - C. The solenoid is removeable by disconnecting the motor lead from the solenoid terminal and removing the two solenoid mounting nuts. When installing a new solenoid, make sure the solenoid plunger engages the shift fork.
 - D. The solenoid is removeable by disconnecting the motor lead from the solenoid terminal and removing the two solenoid mounting nuts. When installing a new solenoid, make sure the solenoid plunger engages the shift fork.

ADJUSTING VALVE LASH

Valve lash is adjustable through the maintenance access opening on gensets with enclosures. Access to Cylinder No. 1 requires removal of the air filter enclosure. See Page 8-1, 8-8 or 8-13, depending on fuel system.

Note: For accurate adjustments, valve lash must be adjust when the engine is at room temperature.

Adjust valve lash (Figure 9-2) for all valves to 0.004 inch (0.01 mm). Torque the adjustment lock nuts to 6.5 lb-ft (8.5 N-m) and recheck lash.

The following procedure is recommended, noting that the intake valves are the upper ones and the exhaust valves the lower ones and that Cylinder No. 1 is to the left (generator side) and Cylinder No. 2 to the right:

1. Remove the spark plugs so that the engine is easier to turn over.
2. Use a socket wrench on the generator pulley nut to turn the engine. Remove the snap-in cover in the access hole in the drip pan. Always turn clockwise so that the nut does not loosen.
3. Remove the valve covers. Have rags in place to catch the oil that spills out.
4. Turn the engine until the Cylinder No. 2 intake valve (top) is at maximum lift. Then adjust Cylinder No. 1 intake valve lash.
5. Turn the engine until the Cylinder No. 2 exhaust valve (bottom) is at maximum lift. Then adjust Cylinder No. 1 exhaust valve lash.
6. Turn the engine until the Cylinder No. 1 intake valve (top) is at maximum lift. Then adjust Cylinder No. 2 intake valve lash.
7. Turn the engine until the Cylinder No. 1 exhaust valve (bottom) is at maximum lift. Then adjust Cylinder No. 2 exhaust valve lash.
8. Secure the valve covers using new gaskets. Torque the cover screws to 5.5 lb-ft (8 N-m).
9. Replace the spark plugs and pulley nut cover.

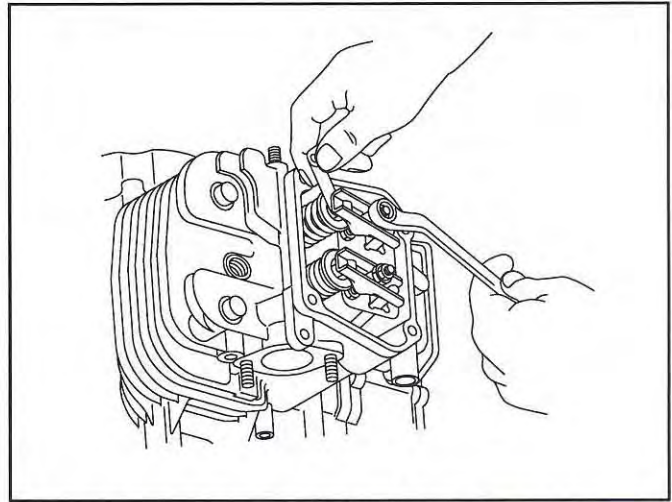

FIGURE 9-2. ADJUSTING VALVE LASH

CYLINDER HEADS AND VALVES

The cylinder heads are removeable after the intake and exhaust manifolds have been removed. See Page 8-1, 8-8 or 8-13 regarding removal of the intake manifold. See Page 7-6 regarding removal of the exhaust manifold.

Removal and Disassembly

To remove the heads from the crankcase, and valves from the heads:

1. Remove the valve covers for access to two of the four head bolts. Have rags in place to catch the oil that spills out.
2. Remove the four head bolts and pull away the head.
3. If the valves are to be removed, place the head on a flat surface and push down on the valve spring retainers, remove the collets and disassemble.
4. Clean the parts thoroughly. Check head flatness, spring free length, valve seat angle and contact width, valve stem diameter and valve guide I. D. against DIMENSIONS AND CLEARANCES (Page 9-15) and replace parts as necessary. Replace burned, pitted or bent valves.

Reassembly and Installation

Reassembly and installation are the reverse of disassembly and removal. Note the following:

1. Lap each valve in place until a uniform ring shows around the face of the valve.
2. Apply oil to the valve stems and install new valve stem seals.
3. Check the head dowel pins and replace if necessary.
4. Install new head gaskets and torque the head bolts in three steps as follows:

Tightening Torques		
Step 1	Step 2	Step 3
7.2 lb-ft (9.8 N-m)	14.5 lb-ft (19.6 N-m)	24.6-30.4 lb-ft (33.3-41.2 N-m)

5. Assemble the push rods and rocker arms (Page 9-6) and adjust valve lash (Page 9-4).

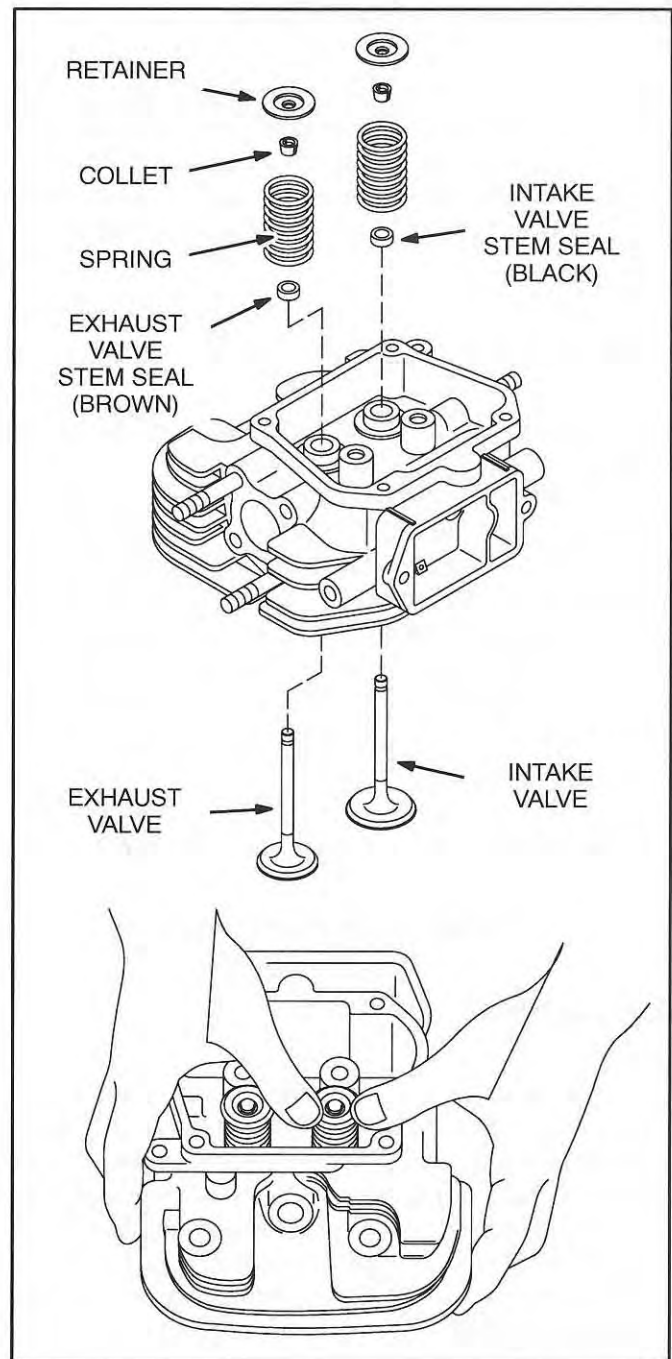

FIGURE 9-3. CYLINDER HEAD AND VALVES

Rocker Arms and Push Rods

After the heads have been assembled to the crankcase the push rods and rocker arms can be assembled loosely as shown in Figure 9-4. Oil the rocker arms and pivots. Insert the push rods into the hollows in the tappets in the crankcase. Adjust valve lash.

Breather Valve

The engine breather is located on the Cylinder No.1 head and consists of a leaf valve (Figure 9-5). The valve maintains a partial vacuum in the crankcase and provides some separation of crankcase gases and oil. The crankcase gases are routed to the air intake for burning in the combustion chambers. Remove, clean and examine the parts and replace as necessary. Re-install the reed valve so that it opens out. Do not tighten the cover screws to more than 3 lb-ft (4 N-m), or the gaskets may be damaged.

Make sure to reconnect the tube between the breather outlet and the back of the air filter.

CRANKCASE ASSEMBLY

Disassembly

After removing the engine from the base (Page 9-3), turn it on its back and remove the main bearing cover screws. Gently tap the cover with a soft-faced hammer to loosen it. If the crank and pistons are to come out, remove the cylinder heads (Page 9-5). Remove the camshaft and tappets and then the pistons and connecting rods and finally the crankshaft. Mark each part so that it can be re-assembled with its mating parts.

Assembly

Before reassembling the crankcase (Figure 9-6), clean all parts thoroughly and check each against DIMENSIONS AND CLEARANCES (Page 9-15). Replace or machine parts as necessary. Replace all gaskets with new. Liberally oil all rotating and sliding parts as they are being assembled. Reassemble the crankcase in the sequence of numbered steps that follow, beginning on (Page 9-8)

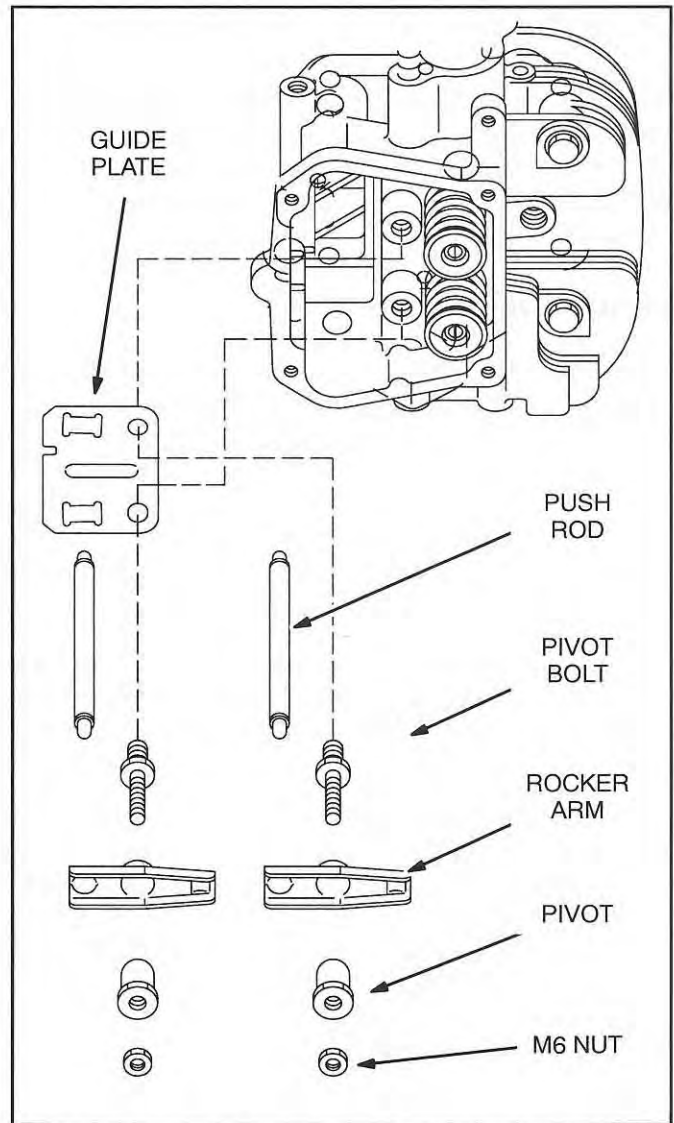

FIGURE 9-4. ROCKER ARMS AND PUSH RODS

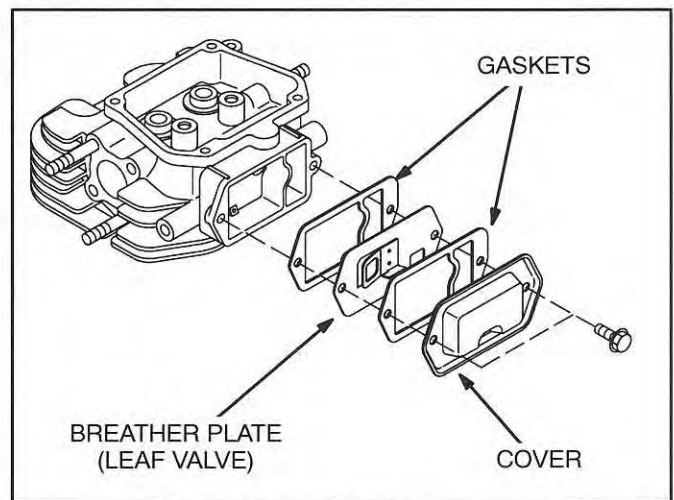

FIGURE 9-5. ENGINE BREATHER VALVE

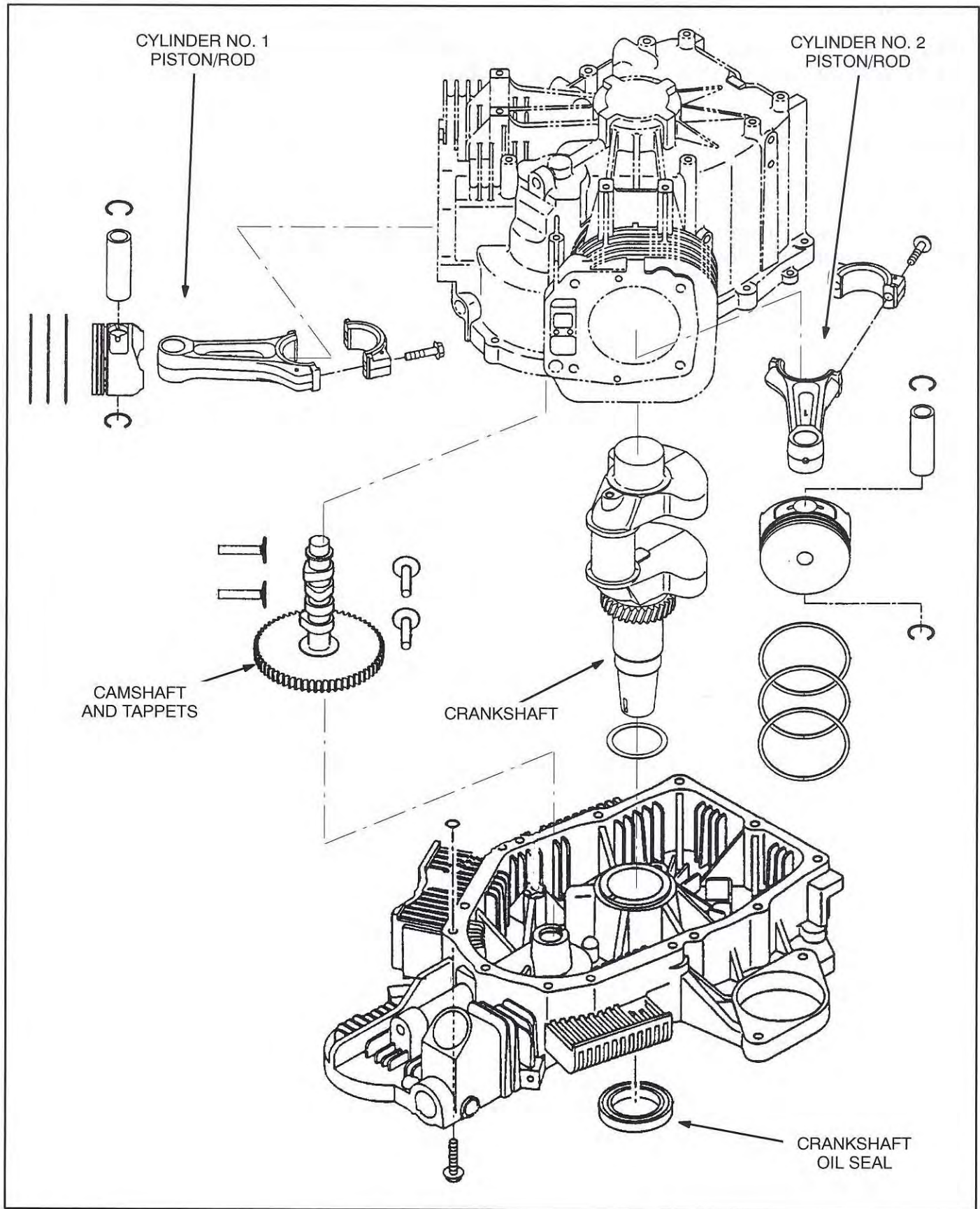

FIGURE 9-6. CRANKCASE ASSEMBLY

Crankshaft

On Models HGJAB, HGJAC, HGJAE and HGJAF install the governor lever and then the crankshaft (Figure 9-7).

Piston Rings

Install the oil ring (bottom) first, then the middle ring and last the top (Figure 9-8). The top ring can be installed either side up. The middle ring has a punch mark on the side that must be up.

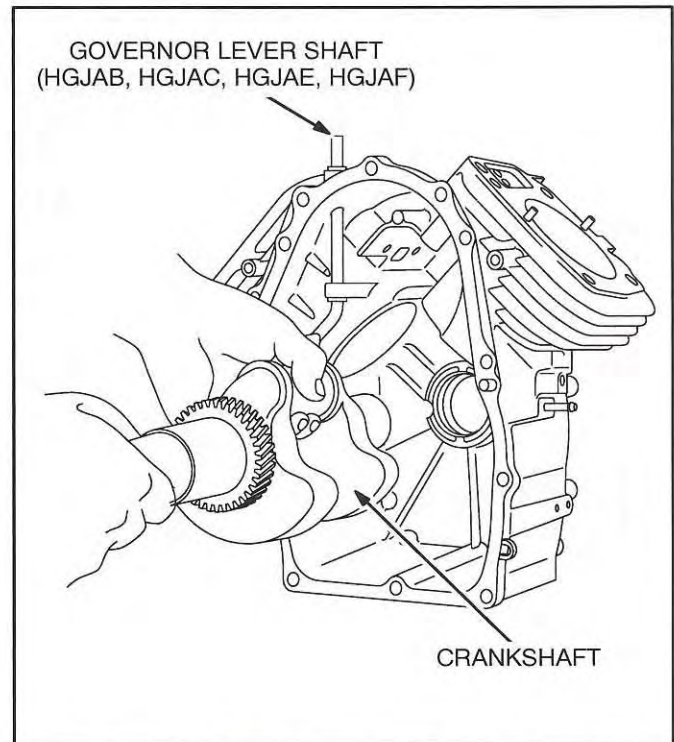

FIGURE 9-7. INSTALLING CRANKSHAFT

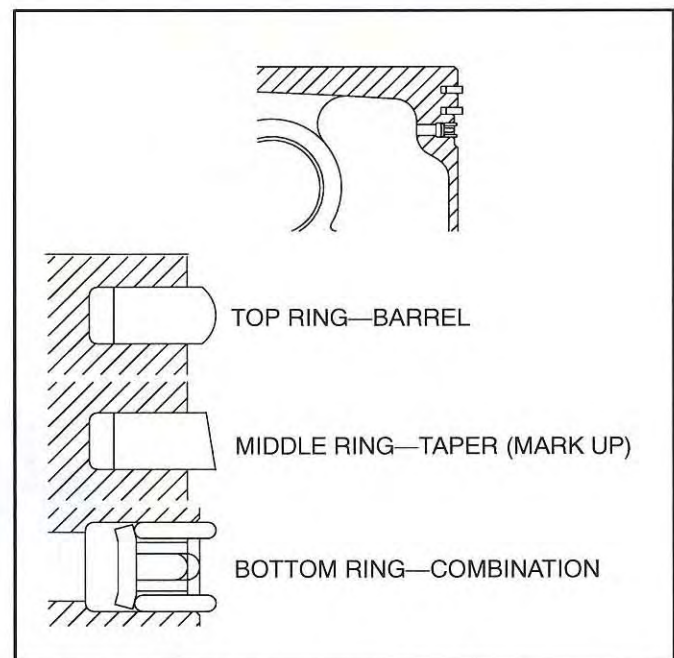

FIGURE 9-8. PISTON RINGS

Piston / Connecting Rod Assembly

Assemble the pistons and connecting rods using both circlips to hold the piston pin in the piston. Note that one connecting rod is marked "1" and the other "2" (Figure 9-9). Assemble in the respective cylinder with the markings on the main bearing cover side.

When installing the connecting rod caps, make sure the alignment marks register (Figure 9-10). Torque the cap bolts to 16.3-19.9 lb-ft (22.1-27 N-m). Check for free movement of piston and connecting rod by turning the crankshaft slowly.

Camshaft and Tappets

Reinstall the tappets in their original bores. Push them in fully to avoid damage during camshaft installation. Install the camshaft and line up the timing marks with the crankshaft gear (Figure 9-11).

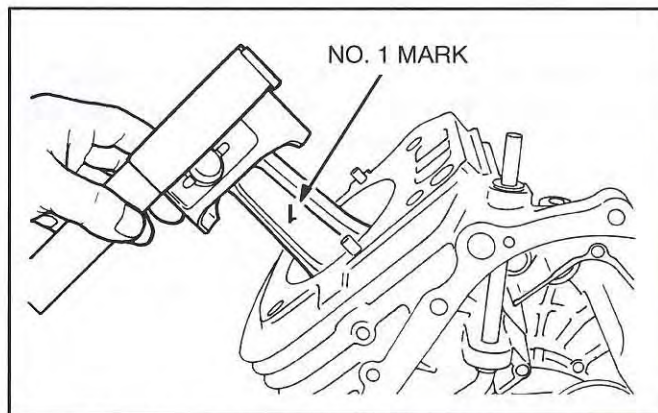

FIGURE 9-9. INSTALLING PISTON / ROD

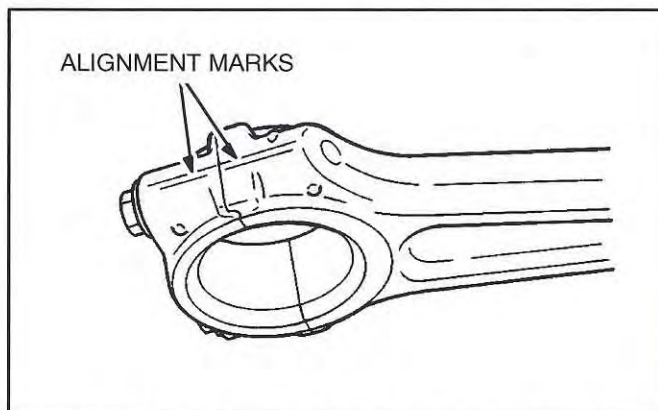

FIGURE 9-10. ROD ALIGNMENT MARKS

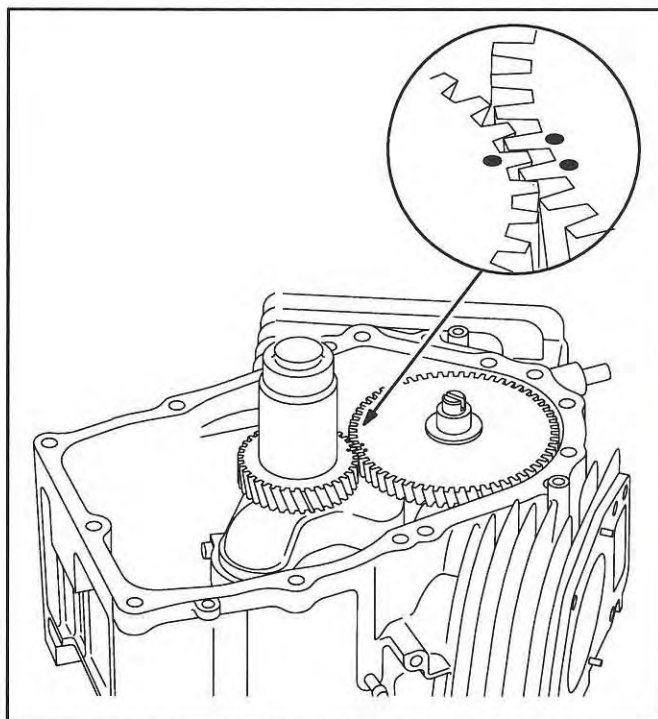

FIGURE 9-11. TIMING MARKS

Crankshaft End Play

Check and adjust crankshaft end play with spacer shims. Three thicknesses are available: 0.6, 0.8 and 1.0 mm (0.024, 0.031 and 0.039 inch). To pick the best shim:

1. Measure and record the A and B distances (Figure 9-12). Figure 9-13 shows a method for determining the B distance. B is equal to Reading 1 minus Reading 2.
2. The thickness of the compressed gasket is 0.014 inch (0.36 mm). Thus:
3. $A + 0.014 \text{ inch} - B = \text{Clearance (inch)}$
[$A + 0.36 \text{ mm} - B = \text{Clearance (mm)}$]
4. Thus, to obtain an end play of 0.008 inch (0.2 mm):
5. $\text{Clearance (inch)} - 0.008 \text{ inch} = \text{Shim Thickness (inch)}$
[$\text{Clearance (mm)} - 0.2 \text{ mm} = \text{Shim Thickness (mm)}$]

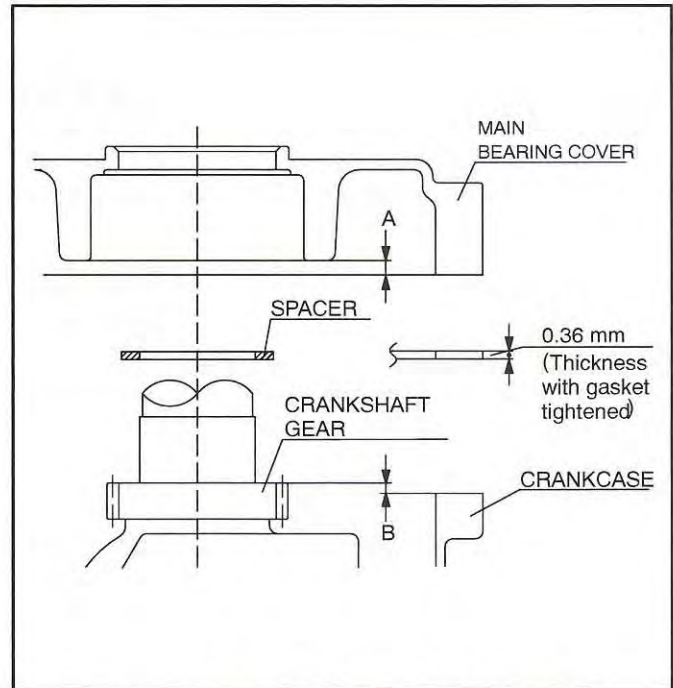

FIGURE 9-12. CRANKSHAFT END PLAY

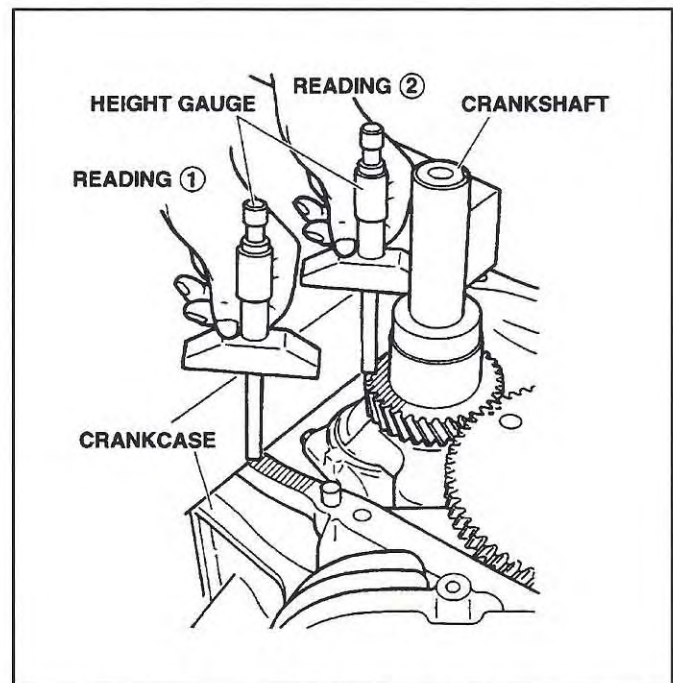

FIGURE 9-13. CRANKSHAFT END PLAY

Crankshaft Oil Seal

Press a new crankshaft oil seal into the main bearing cover to a depth of 0.020 to 0.060 inches (0.5 to 1.5 mm) below the surface.

⚠ CAUTION *Pressing the oil seal in too far will result in an oil leak.*

If the crankshaft has been grooved or has nicks or scratches where the oil seal touches the crankshaft, it is recommended that a "Speedi-Sleeve" be installed. See **PSB 686** for "Speedi-Sleeve" use and installation instructions.

Main Bearing Cover

Install a seal guide over the crankshaft to protect the crankshaft oil seal. On Models HGJAB, HGJAC, HGJAE and HGJAF make sure the governor gear (Page 10-1) has been installed.

Use a new cover gasket and 3-Bond or an RTV adhesive sealant equivalent to Dow Corning 732.

Make sure both O-rings (187-6239) are in place, one at each oil return hole from the block.

Lubricate the oil seal lip and gently guide the cover on over the crankshaft to prevent damaging the oil seal, making sure that the governor gear meshes with the camshaft gear. If necessary, poke a thin rod through the gap between crankcase and cover to turn the governor gear slightly so that the teeth mesh.

Torque the cover screws to 16.2-16.9 lb-ft (22-23 N-m).

Note: Replace all cover screws that are not imprinted with the number "9" with Onan Part Number 800-6361. These are newer, stronger screws necessary for securing the cover tighter to prevent oil leaks.

Lubricating Oil Pump

The crankshaft and camshaft journals are pressure lubricated, while the cylinders and valve system are lubricated by the oil mist in the crankcase. The oil pump is driven by the camshaft through a coupling on the end of the camshaft. A full-flow oil filter and low oil pressure cutoff switch are mounted externally (Figure 9-1).

Low Oil Pressure Switch: The genset controller will blink Fault Code No. 2—Low Oil Pressure if there is a loss of oil pressure (less than 17 psi). Nominal oil pressure is 43 psi. See Section 11. *Troubleshooting*.

Removing Oil Pump: To remove the oil pump for service (Figure 9-14), it will be necessary to remove the flywheel but not to remove the engine from the base. See Section 7. *Fan, Drive Belt, Flywheel, Ignition, Exhaust* to remove the flywheel. Then remove the four mounting screws and remove the pump components (Figure 9-15).

Reinstalling Oil Pump: Clean, service and replace pump parts as necessary (Figure 9-15) and relubricate before installing. Make sure the shaft engages the end of the camshaft properly.

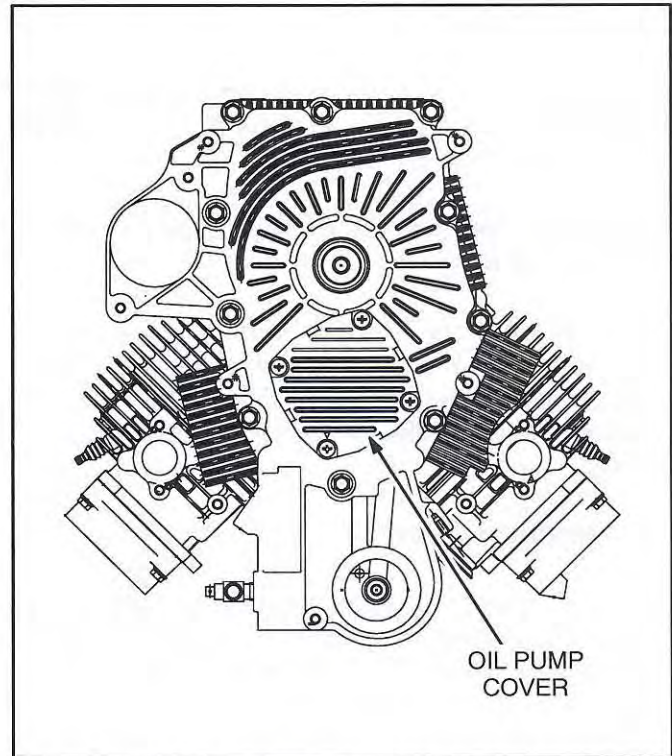

FIGURE 9-14. OIL PUMP COVER (ENGINE BOTTOM)

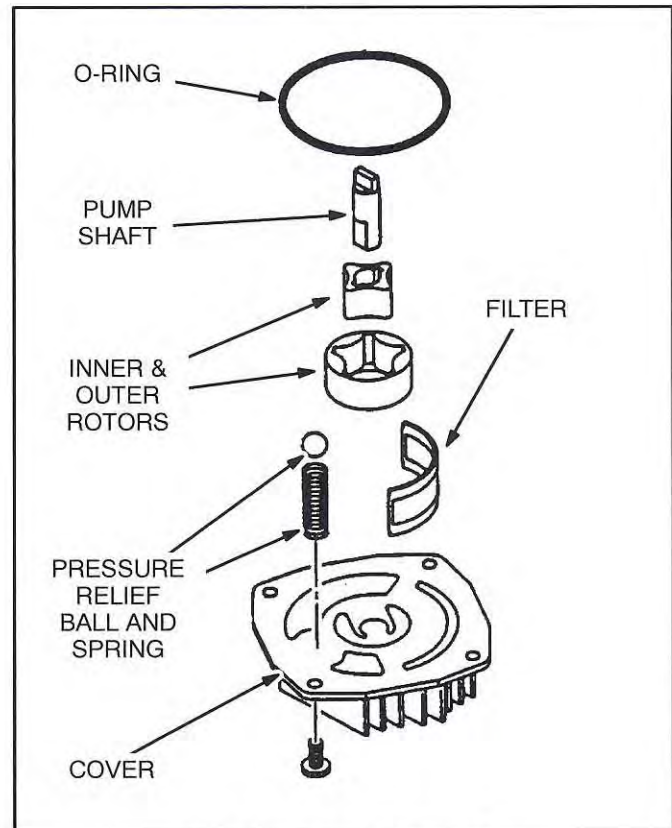

FIGURE 9-15. OIL PUMP

Oil Control Leaf Valves

A leaf valve is secured by two screws and a retainer plate in the push rod compartment along side each cylinder (Figure 9-16). The valves control the mist of crankcase gases and oil that pass through the heads lubricating the valve system. The oil drops out and returns to the crankcase through passages in the heads and crankcase while the breather valve (Page 9-6) prevents accumulation of the crankcase gases.

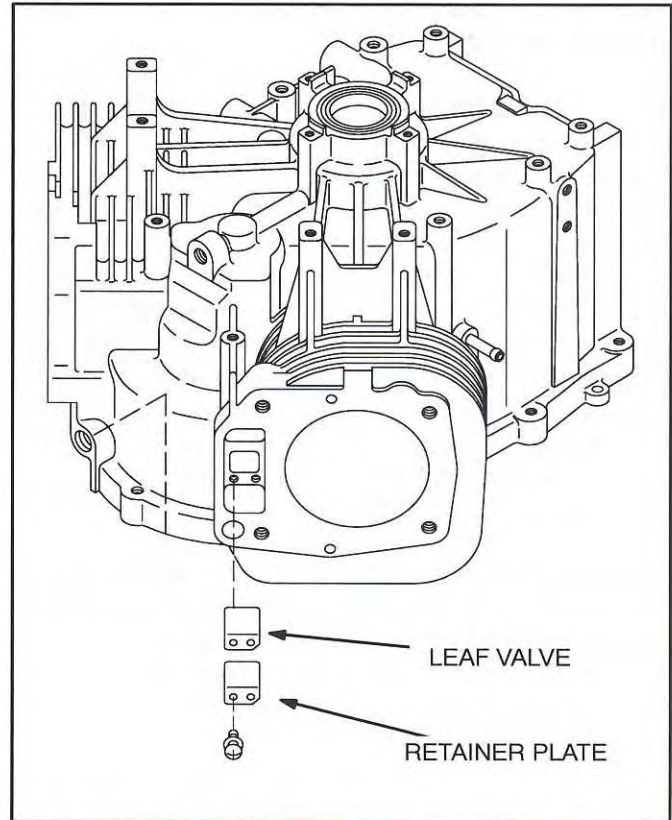

FIGURE 9-16. OIL CONTROL LEAF VALVES

Mechanical Governor—HGJAB, HGJAC, HGJAE, HGJAF

The internal components of the mechanical governor are accessible when the main bearing cover is removed. The governor gear assembly rotates on a shaft projecting from the bearing cover and snaps in place in the groove in the shaft (Figure 10-1). It is driven by the camshaft gear. The governor lever is carried in the crankcase and protrudes out the side (Figure 9-17), where the governor arm is attached (Page 8-20). The governor sleeve (Figure 10-1) pushes up on the paddle of the governor lever shaft (Figure 9-17). It opposes, in proportion to engine speed, the force of the external governor spring (Page 8-20).

Be careful when assembling the main bearing cover to the crankcase that the governor and camshaft gears mesh properly. If necessary, poke a thin rod through the gap between crankcase and cover to turn the governor gear slightly so that the teeth mesh.

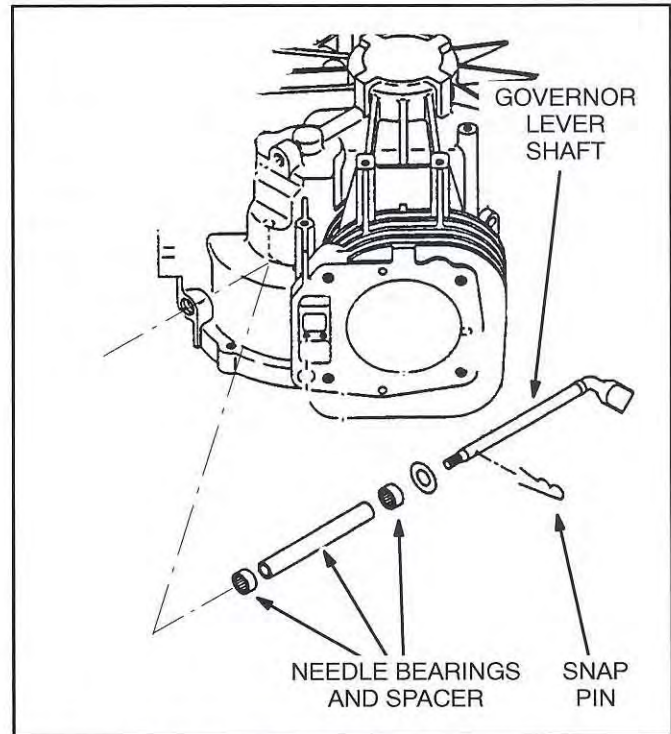

FIGURE 9-17. GOVERNOR LEVER

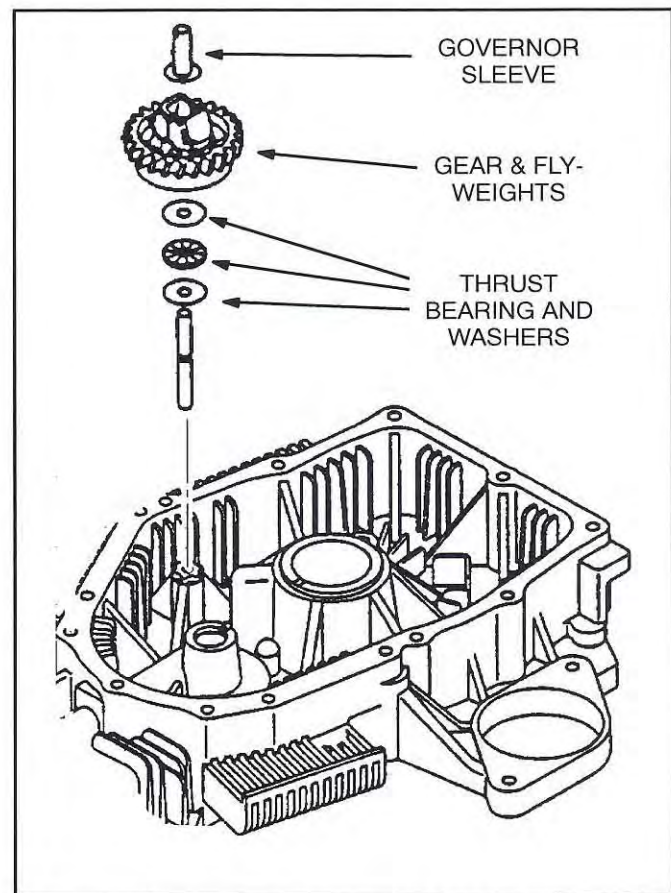
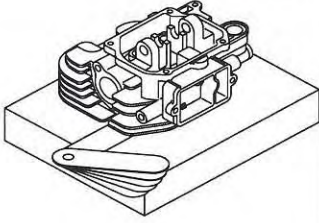
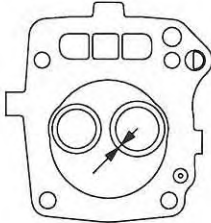
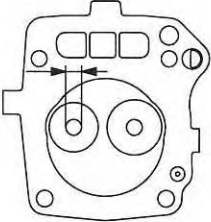
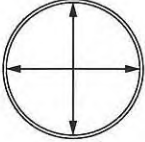
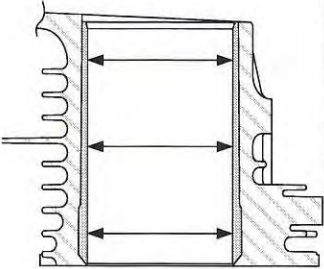
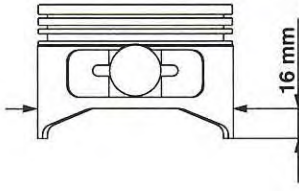
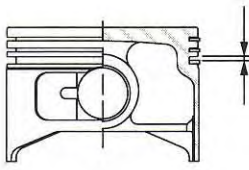
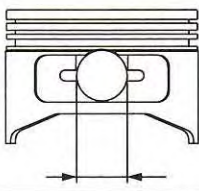
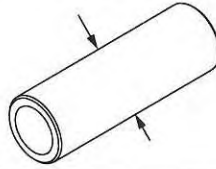
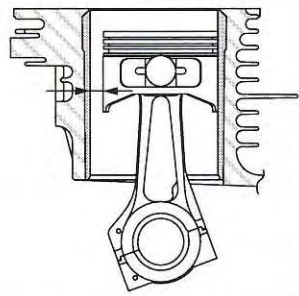
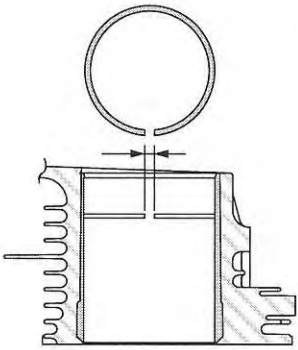
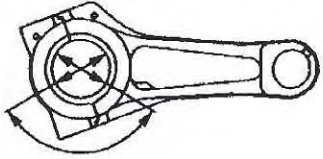
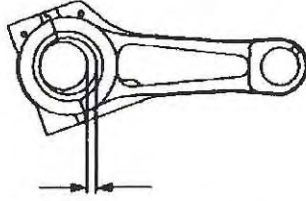
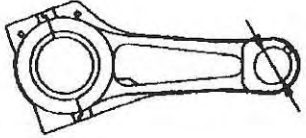
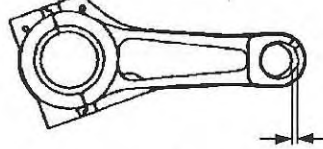
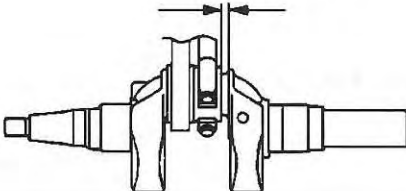

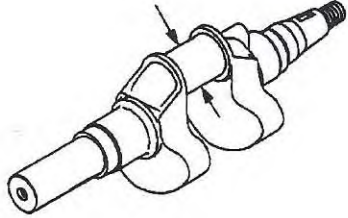
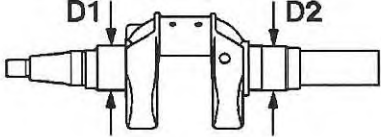
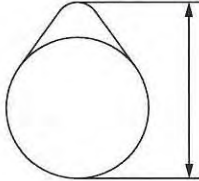
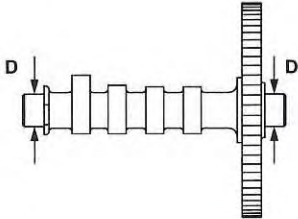
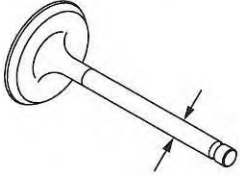

FIGURE 9-18. GOVERNOR GEAR

DIMENSIONS AND CLEARANCES

ITEM	STANDARD inches (mm)	MAXIMUM inches (mm)	
Cylinder Head			
Flatness 	0.002 or less (0.05 or less)	0.004 (0.1)	
Valve seat contact width 	Intake/ Exhaust 0.028 – 0.039 (0.7 – 1.0)	0.079 (2.0)	
Valve guide inside diameter 	0.2376 – 0.2383 (6.035 – 6.053)	0.242 (6.15)	
Cylinder			
Inside diameter  	STD	3.1496 – 3.1504 (80.000 – 80.019)	Rebore when the difference between the max. and min. of diameter reaches 0.004 (0.1)
	1st Reboring	3.159 – 3.160 (80.250 – 80.269)	3.159 – 3.160 (80.250 – 80.269)
	2nd Reboring	3.169 – 3.170 (80.500 – 80.519)	_____
	Roundness after reboring	0.004 (0.01)	_____
	Cylindricity after reboring	0.0006 (0.015)	_____

ITEM		STANDARD inches (mm)	MAXIMUM inches (mm)
Piston Piston size (at skirt in thrust direction) 	STD	3.148 – 3.149 (79.968 – 79.988)	3.145 (79.878)
	1st outer diameter	3.158 – 3.159 (80.218 – 80.238)	3.155 (80.128)
	2nd outer diameter	3.168 – 3.169 (80.468 – 80.488)	3.164 (80.378)
Ring groove side clearance 	Top	0.0002 – 0.0035 (0.05 – 0.09)	0.006 (0.15)
	2nd	0.0012 – 0.0028 (0.03 – 0.07)	0.006 (0.15)
	Oil Ring	0.0022 – 0.0069 (0.057 – 0.175)	0.006 (0.15)
Piston pin hole 		0.8262 – 0.8269 (20.989 – 21.002)	0.8281 (21.035)
Piston pin outer di- ameter 		0.8264 – 0.8268 (20.991 – 21.000)	0.8251 (20.960)
Clearance between piston and cylinder at skirt area 		0.0005 – 0.0020 (0.012 – 0.051)	0.0098 (0.25)

ITEM		STANDARD inches (mm)	MAXIMUM inches (mm)	
Piston <i>(continued)</i> Piston ring end gap		Top 2nd	0.0079 – 0.0157 (0.2 – 0.4)	0.0591 (1.5)
		Oil Ring	0.0079 – 0.0276 (0.2 – 0.7)	0.0591 (1.5)
Connecting Rod				
Large end inner diameter	 120°	1.5354 – 1.5361 (39.000 – 39.016)	1.5394 (39.100)	
Clearance between crankpin and inner diameter		0.0012 – 0.0024 (0.030 – 0.060)	0.0079 (0.2)	
Small end inner diameter		0.8272 – 0.8277 (21.010 – 21.023)	0.8299 (21.080)	
Clearance between piston pin and inner diameter		0.0004 – 0.0013 (0.010 – 0.032)	0.0047 (0.12)	
Large end side clearance		0.0039 – 0.0157 (0.1 – 0.4)	0.0394 (1.0)	

ITEM		STANDARD inches (mm)	MAXIMUM inches (mm)
Crankshaft			
Crankpin outer diameter		1.5337 – 1.5343 (38.956 – 38.970)	1.5315 (38.90)
Journal diameter		D1: 1.77102 – 1.77165 (44.984 – 45.000) D2: 1.77110 – 1.77154 (44.986 – 44.997)	_____
End Play		0.005 – 0.012 (0.127 – 0.305)	
Camshaft			
Cam height (internal and external)		1.4213 – 1.4291 (36.1 – 36.3)	1.4154 (35.95)
Journal outer diameter "D"		0.7861 – 0.7866 (19.967 – 19.980)	0.7854 (19.950)
Valve			
Valve stem outer diameter		Intake 0.2350 – 0.2356 (5.970 – 5.985) Exhaust 0.2346 – 0.2352 (5.960 – 5.975)	0.2303 (5.85)
Clearance between valve stem and valve stem guide		Intake 0.0022 – 0.0033 (0.050 – 0.083) Exhaust 0.0024 – 0.0037 (0.060 – 0.093)	0.0118 (0.30)

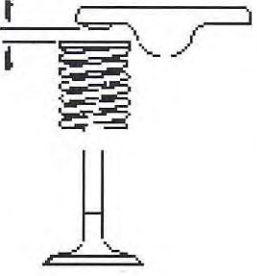
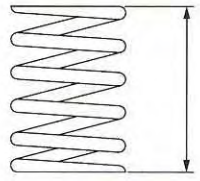
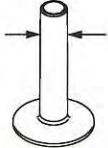
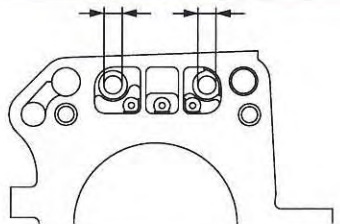
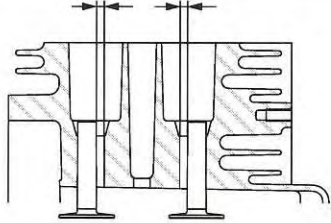
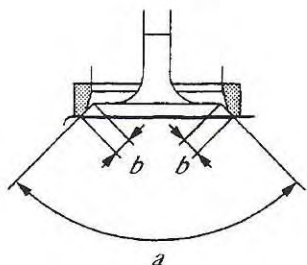
ITEM		STANDARD inches (mm)	MAXIMUM inches (mm)
Valve <i>(continued)</i> Valve clearance	 Intake/ Exhaust Measured Cold	0.0034 – 0.0045 (0.085 – 0.115)	
Valve spring Free length		1.5551 (39.5)	—
Tappet Outer stem diameter		0.03528 – 0.3533 (8.960 – 8.975)	0.3516 (8.93)
Inner guide diameter		0.3543 – 0.3549 (9.00 – 9.015)	0.3575 (9.08)
Tappet guide clearance		0.0010 – 0.0022 0.025 – 0.055)	0.0059 (0.15)
Valve seat angle Cut angle (a) Contact width (b)		a: 90° b: 0.028 – 0.039 (0.7 – 1.0)	0.079 (2.0)

This side is intentionally blank

10. Hydraulic Pump

The optional hydraulic pump, when provided, is mounted atop the engine (Figure 10-1). See Section 13. *Specifications* regarding hose fittings, fluid specifications and inlet conditions.

INSTALLING THE HYDRAULIC PUMP

When installing the pump, apply molybdenum disulfide paste or equivalent to the shaft spline and torque the two flange screws to 20 lb-ft (26 N-m). Do not start the genset before the hydraulic pump has been connected to the hydraulic system and filled with oil.

⚠ CAUTION *Running the genset without oil in the hydraulic pump will destroy the pump.*

⚠ CAUTION *The slightest amount of dirt in an hydraulic system can damage precisely machined internal components. Keep dirt out:*

- *Thoroughly clean the outside of a fitting or cap before disconnecting or removing it.*
- *Keep all openings in components and hoses capped with proper JIC caps until just before making connections.*
- *Thoroughly flush hoses before connecting.*
- *Regularly replace the oil filter.*
- *Never reuse hydraulic fluid that has been drained from a system.*

CONNECTING HYDRAULIC HOSES

⚠ WARNING *The high pressure spray from a leak or fitting in a hydraulic line can penetrate the skin, leading to possible blood poisoning — Wear safety glasses — Shut down the genset before loosening or tightening fittings — Do not delay getting proper medical attention if exposed to high pressure oil spray.*

When connecting hoses and starting up the system:

1. Consider that hoses shrink slightly in length and expand slightly in diameter under pressure.
2. There must be enough slack in the connected hoses to prevent strain due to movement of the pump.

3. Support, restrain and protect hydraulic hose as necessary to prevent chaffing.
4. Do not bend hose tighter than the hose manufacturer recommends.
5. Use wide-sweep 90-degree fittings.
6. Always use two wrenches when tightening hydraulic fittings.
7. Install an SAE Class 4 filter (10 micron) in the system.
8. The system oil reservoir should be above the pump and the hose from the pump should slope up to the reservoir.
9. To fill the pump, first fill the reservoir and crank the engine with the spark plug cables disconnected from the spark plugs to prevent the engine from starting. Replenish oil in the reservoir as necessary.
10. The installed system must not cause pump inlet conditions to exceed *Specifications*.

⚠ CAUTION *Continuing to run or load a noisy pump can destroy it. Purge the air before continuing.*

11. The hydraulic system has air in it as long as there continues to be sharp metallic noise. Run the genset for a few seconds at a time until all air has been purged.

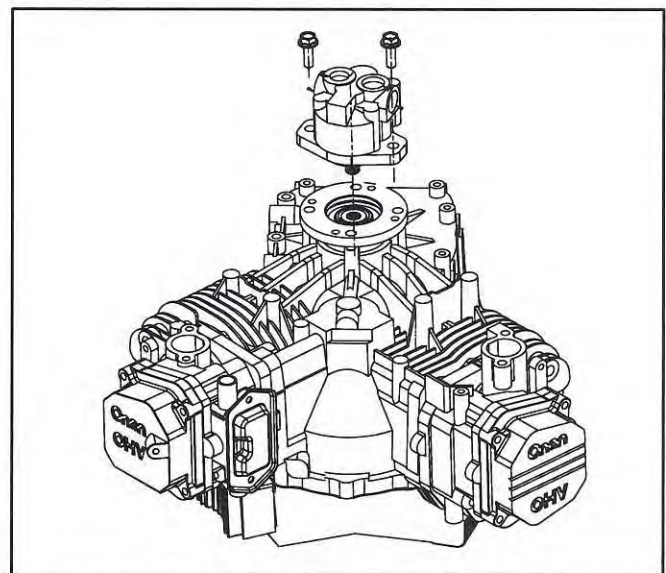

FIGURE 10-1. HYDRAULIC PUMP

This side is intentionally blank

Faint, illegible text, likely bleed-through from the reverse side of the page.

Faint, illegible text, likely bleed-through from the reverse side of the page.

11. Troubleshooting

⚠WARNING *Hot engine parts can cause severe burns. Always allow the engine time to cool before performing any maintenance or service.*

The Fault Codes are listed in numerical order along with step-by-step corrective actions. Refer to the appropriate wiring diagram and harness drawings beginning on Page A-1.

First note the following:

- Maintaining engine oil level, keeping battery connections clean and tight, watching the fuel gauge, not overloading the genset, etc. will prevent most shutdowns.
- When the genset and vehicle engine share a common fuel tank the fuel dip tubes are usually arranged so that the genset will run out of fuel first. Marking the genset empty point on the fuel gauge will make it easier to tell when to stop the genset before running it out of fuel.

FAULT CODES

The genset controller provides extensive diagnostics by causing the status indicator light on the Control Switch to blink in coded fashion. Following a fault shutdown, the indicator light will repeatedly blink 2, 3 or 4 blinks at a time.

- **Two blinks** indicates a low oil pressure fault.
- **Three blinks** indicates a service fault. Press **Stop** once to cause the two-digit, second-level fault code to blink. (Pressing **Stop** again will stop the blinking.) The two-digit code consists of 1, 2, 3, 4 or 5 blinks, a brief pause, and then 1 to 9 blinks. The first set of blinks represents the tens digit and the second set of blinks the units digit of the fault code number. For example, **Fault Code No. 36** appears as:

blink-blink-blink—*pause*—blink-blink-blink-blink-blink-blink—
long pause—repeat

- **Four blinks** indicates that cranking exceeded 30 seconds without the engine starting.
- **Note: Fault Code Nos. 3 and 4 are first level faults. Avoid interpreting them as second-level Fault Code Nos. 33 and 44, which have purposely not been assigned as fault codes.**

Restoring Fault Code Blinking – The fault code stops blinking after five minutes (15 minutes, Series HGJAA & HGJAD). Press **Stop** three times within five seconds to restore blinking. **Note that the last fault logged will blink even after the condition that caused the shutdown has been corrected.**

GENSET STARTS OR STOPS WITHOUT COMMAND – NO FAULT CODE

⚠WARNING *Some genset service procedures present hazards that can result in severe personal injury or death. Only trained and experienced persons with knowledge of fuels, electricity, and machinery hazards should perform genset service. See Safety Precautions.*

Logic: To start or stop – control receives ground at start or stop input on control, DC voltage drops below 9V and controller de-energizes (shuts down in sleep mode)

Possible Cause: Low battery voltage, shorted harness connection, faulty start/stop switch, Auto Gen Start (AGS) is enabled

Diagnosis and Repair:

1. Check last fault and record.
2. Measure battery voltage at battery and genset.
3. Inspect battery connections and cables for cleanliness, tightness and damage: clean, tighten and repair connections and cables as necessary.
4. Check electrolyte level and hydrometer reading in maintenance type batteries: replace electrolyte and recharge or replace battery as necessary.
5. Disconnect genset control P1 connector, verify P1 pins are fully inserted and inspect pin condition per PSB-676: insert, repair or replace pins as necessary.
6. Reconnect P1 connector and test run genset for symptom: repair or replace pins in connector as necessary.
7. Measure battery voltage at genset while attempting to start from local or remote switch: recharge or replace battery if voltage drops below 9 VDC, test and service genset battery charger if so equipped, increase battery cable size or run parallel cables.
8. Measure battery voltage and check for charger increase while genset is running.
9. Measure for continuity change across start/stop switch between neutral and start position and neutral and stop position at switches and at connector P1: reconnect or repair connections, replace switches as necessary.
10. Measure for continuity from start and stop inputs to ground at switches and at connector P1: Repair or replace damaged harness.
11. Determine if AGS is installed and enabled (AGS will command start and stop based on its own settings): disable AGS or explain AGS function to customer (see PSB-666).

NO RESPONSE – STATUS INDICATOR LIGHT DEAD

⚠️WARNING *Some genset service procedures present hazards that can result in severe personal injury or death. Only trained and experienced persons with knowledge of fuels, electricity, and machinery hazards should perform genset service. See Safety Precautions.*

Logic: To start – control receives ground via start/stop switch to start or stop input on control

Possible Cause: Low/No battery voltage, poor battery connection, faulty battery, open harness connection, faulty start/stop switch, faulty LED

Diagnosis and Repair:

1. Measure battery voltage at battery, at genset and at connector P1: reconnect, clean, repair and replace connections as necessary.
2. Measure battery voltage at genset while attempting to start or prime from local or remote switch: recharge or replace battery if voltage drops below 9 VDC, test and service genset battery charger if so equipped, increase battery cable size or run parallel cables.
3. Measure for continuity change across start/stop switch between neutral and start position and neutral and stop position at switches and at connector P1: reconnect or repair connections, replace switches as necessary.
4. Test switches LED by energizing with 12 VDC: replace switches as necessary.
5. Disconnect genset control P1 connector, verify P1 pins are fully inserted and inspect pin condition per PSB-676: insert, repair or replace pins as necessary.
6. Reconnect P1 connector and test run genset for start and prime operation: replace control as necessary.

STARTING BATTERIES RUN DOWN

⚠️WARNING *Some genset service procedures present hazards that can result in severe personal injury or death. Only trained and experienced persons with knowledge of fuels, electricity, and machinery hazards should perform genset service. See Safety Precautions.*

Logic: Low/No battery voltage

Possible Cause: Battery connections, battery, charging system, excessive cranking, excessive priming

Diagnosis and Repair:

1. Measure battery voltage at battery and genset.
2. Inspect battery connections and cables for cleanliness, tightness and damage: clean, tighten and repair connections and cables as necessary.
3. Check electrolyte level and hydrometer reading in maintenance type batteries: replace electrolyte and recharge or replace battery as necessary.
4. Verify battery charger is on and check operation.
5. Measure battery voltage and check for charging increase while genset is running.
6. Check last fault and record: troubleshoot as necessary.
7. Disconnect genset control P1 connector, verify P1 pins are fully inserted and inspect pin condition per PSB-676: insert, repair or replace pins as necessary.
8. Reconnect P1 connector and test run genset for fault occurrence: repair or replace pins in connector as necessary.
9. Measure for continuity change across start/stop switch between neutral and stop position at switches and P1 connector: replace switches as necessary or disconnect external stop device if so equipped.
10. Measure for voltage at fuel pump while genset is not running or being primed: replace control as necessary.

STARTER ENGAGES – DISENGAGES

⚠️WARNING *Some genset service procedures present hazards that can result in severe personal injury or death. Only trained and experienced persons with knowledge of fuels, electricity, and machinery hazards should perform genset service. See Safety Precautions.*

Logic: Cranking voltage dips below 6 VDC: microprocessor aborts start attempt

Possible Cause: Battery connections, battery, charging system, start/stop switches, engine compression

Diagnosis and Repair:

1. Measure battery voltage at battery and genset.
2. Inspect battery connections and cables for cleanliness, tightness and damage: clean, tighten and repair connections and cables as necessary.
3. Check electrolyte level and hydrometer reading in maintenance type batteries: replace electrolyte and recharge or replace battery as necessary.
4. Disconnect genset control P1 connector, verify P1 pins are fully inserted and inspect pin condition per PSB-676: insert, repair or replace pins as necessary.
5. Reconnect P1 connector and test run genset for fault occurrence: repair or replace pins in connector as necessary.
6. Measure battery voltage at genset while attempting to start from local or remote switch: recharge or replace battery if voltage drops below 9 VDC, test and service genset battery charger if so equipped, increase battery cable size or run parallel cables.
7. Measure battery voltage and check for charger increase while genset is running.

NO AC POWER – GENSET RUNNING, STATUS LED ON STEADY OR FLASHING RAPIDLY

⚠️WARNING *Some genset service procedures present hazards that can result in severe personal injury or death. Only trained and experienced persons with knowledge of fuels, electricity, and machinery hazards should perform genset service. See Safety Precautions.*

Logic: Genset control in normal or Engine Run Only mode

Possible Cause: Circuit breakers, Engine Run Only mode due to faulty generator

Diagnosis and Repair:

1. Status light on – Measure AC output at genset circuit breaker: reset or turn on genset circuit breaker, diagnose faulty loads as necessary
2. **HGJAD, E, F Models** – (Rapid flashing status light – Engine Run Only mode)
 - A. Remove connector P1 from control and re-install and try to start genset: inspect, repair or replace P1 connector pins as necessary.
 - B. While running in Engine Run Only mode externally excite field with 12 VDC or 24 VDC and measure main and quadrature winding AC output.
 - C. Measure field, quadrature and main winding resistance: clean slip rings, replace brushes, repair harness and replace rotor or stator as necessary.
 - D. Measure field, quadrature and main winding resistance to ground: clean slip rings, replace brushes, repair harness and replace rotor or stator as necessary.
 - E. Measure field, quadrature and main winding resistance to each other: clean slip rings, replace brushes, repair harness and replace rotor or stator as necessary.
 - F. Check brush alignment per PSB-682a.

GENSET CRANKS BUT DOES NOT START – NO FAULT CODE

⚠WARNING *Some genset service procedures present hazards that can result in severe personal injury or death. Only trained and experienced persons with knowledge of fuels, electricity, and machinery hazards should perform genset service. See Safety Precautions.*

Logic: Fault codes are based on time lapse between events

Possible Cause: Not holding start switch long enough to cause fault

Diagnosis and Repair:

1. Check and record last fault code.
2. Crank genset and hold switch until control stops cranking and displays fault code (approximately 30 seconds): troubleshoot fault code and reference last fault code recorded above if necessary.

GENSET RUNS BUT STOPS WHEN SWITCH IS RELEASED – NO FAULT CODE

⚠WARNING *Some genset service procedures present hazards that can result in severe personal injury or death. Only trained and experienced persons with knowledge of fuels, electricity, and machinery hazards should perform genset service. See Safety Precautions.*

Logic: Fault codes are based on time lapse between events

Possible Cause: Not holding start switch long enough to cause fault

Diagnosis and Repair:

1. Check and record last fault code.
2. Start genset and hold switch until control shuts down and displays fault code (approximately 30 seconds): troubleshoot fault code and reference last fault code recorded above if necessary.

LOW OIL PRESSURE FAULT – FAULT CODE 2

⚠WARNING *Some genset service procedures present hazards that can result in severe personal injury or death. Only trained and experienced persons with knowledge of fuels, electricity, and machinery hazards should perform genset service. See Safety Precautions.*

Logic: Continuous ground at control for oil pressure input

Possible Cause: Low/high oil level, faulty switch, faulty oil pressure relief valve, fault oil pump

Diagnosis and Repair:

1. Verify that Last Fault is FC 2: Yes, continue diagnosis; No, troubleshoot actual last fault.
2. Measure oil level: add or drain oil as necessary.
3. Disconnect genset control P1 connector, verify P1 pins are fully inserted and inspect pin condition per PSB-676: insert, repair or replace pins as necessary.
4. Reconnect P1 connector and test run genset for fault occurrence: repair or replace pins in connector as necessary.
5. Measure continuity change across start/stop switch between rest and under simulated pressure: replace switch as necessary.
6. **HGJAB, C** – Measure continuity between ground and P1-13: repair or replace harness as necessary.
HGJAA, D, E, F – Measure continuity between ground and P1-6: repair or replace harness as necessary.
7. Measure oil pressure with mechanical gauge: repair or replace relief valve and oil pump as necessary.

SERVICE CHECK FAULT – FAULT CODE 3

⚠️WARNING *Some genset service procedures present hazards that can result in severe personal injury or death. Only trained and experienced persons with knowledge of fuels, electricity, and machinery hazards should perform genset service. See Safety Precautions.*

Logic: Single-Digit Fault to indicate shutdown due to a Two-Digit Fault

Possible Cause: Any Two-Digit Fault Code

Diagnosis and Repair:

1. Verify that Last Fault is FC 3: Yes, continue diagnosis; No, troubleshoot actual last fault.
2. While LED is flashing three times press stop once (1 second duration): trouble shoot Two-Digit Fault Code.

OVERCRANK – FAULT CODE 4

⚠️WARNING *Some genset service procedures present hazards that can result in severe personal injury or death. Only trained and experienced persons with knowledge of fuels, electricity, and machinery hazards should perform genset service. See Safety Precautions.*

Logic: Controller unable to sense genset frequency after 30 seconds of holding start switch

Possible Cause: Faulty switch, faulty external start command, fuel supply, air fuel mixture, exhaust system, wire connections, starter, ignition system

Diagnosis and Repair:

1. Verify that Last Fault is FC 4: Yes, continue diagnosis; No, troubleshoot actual last fault.
2. Measure for continuity change across start/stop switch between neutral and start position at switches and P1 connector: replace switches as necessary or disconnect external start device if so equipped.
3. Disconnect genset control P1 connector, verify P1 pins are fully inserted and inspect pin condition per PSB-676: insert, repair or replace pins as necessary.
4. Reconnect P1 connector and test run genset for fault occurrence: repair or replace pins in connector as necessary.
5. Verify engine rotation manually: repair engine damage as necessary.
6. Measure DC voltage at starter during start attempt: repair wire connections, replace start solenoid and starter as necessary.
7. Check air filter cleanliness; replace air filter as necessary.
8. Check for blocked or damaged exhaust system: repair or replace exhaust components as necessary.
9. **All Gasoline Models**
 - A. Vapor lock may occur in high ambient temperatures: operate in ambients at less than 120°F; verify proper installation to prevent air recirculation; correct as necessary.
 - B. Measure steady DC voltage at fuel pump while genset is cranking: repair wiring as necessary.
 - C. Try to start genset on shop fuel supply: verify tank level and fuel line condition in vehicle.

10. All Gasoline Carburetor Models

- A. Verify carburetor altitude setting: readjust as necessary.
- B. Verify choke operation, setting, linkage, vacuum pull off assembly and sustain valve: readjust, repair or replace as necessary.
- C. Measure fuel pump pressure/flow: replace fuel filter or fuel pump as necessary.
- D. Inspect carburetor butterfly for binding: replace carburetor as necessary.

11. All Gasoline EFI Models

- A. Inspect throttle body for binding or damage: replace as necessary.
- B. Measure fuel pump pressure/flow: replace fuel filter, pressure regulator or fuel pump as necessary.

12. Propane Models

- A. When ambient temperatures are less than 40°F vapor-withdrawal Propane tanks should be at least half full to provide proper vaporization rate.
 - B. Propane having more than 2.5 percent Butane will not vaporize in ambients at less than 32°F; use HD-5 grade Propane.
 - C. Measure steady DC voltage at fuel solenoid while genset is running; repair wiring as necessary.
 - D. Verify clear vent hose.
 - E. Run genset on shop fuel supply; verify tank level and fuel line condition in vehicle.
 - F. Check genset fuel lines for damage: replace fuel line as required.
 - G. Measure regulator lock off pressure.
13. Check governor, actuator, linkage and spring for debris, damage and looseness: readjust and repair as necessary.
14. Verify that spark plug cables are secure on spark plugs: reconnect or replace as necessary.
15. Measure DC voltage from ignition kill lead greater than 1 VDC: repair or replace leads, pins or magnetos as necessary.
16. Inspect ignition kill leads in harness and at connector P1: repair or replace lead, terminal or pins as necessary.
17. Test Magnetos:
- A. Disconnect Connector P1.
 - B. Connect positive(+) meter lead to chassis ground.
 - C. **HGJAA, D, E, F** – Measure continuity to negative lead at pin P1-4 and P1-5: replace magnetos as necessary.
 - D. **HGJAB, C** – Measure continuity to negative lead at pin P1-15 and P1-20: replace magnetos as necessary.
18. Measure spark plug gap: set gap or replace spark plugs as necessary.
19. Verify ignition spark condition.
20. Inspect spark plug lead, kill lead terminal at magneto and measure magneto air gap: replace terminals, set gap or replace magnetos as necessary.
21. Measure field, quadrature and main winding resistance: clean slip rings, replace brushes, repair harness and replace rotor or stator as necessary.
22. Measure field, quadrature and main winding resistance to ground: clean slip rings, replace brushes, repair harness and replace rotor or stator as necessary.
23. Measure field, quadrature and main winding resistance to each other: clean slip rings, replace brushes, repair harness and replace rotor or stator as necessary.
24. Check brush alignment per PSB-682a.
25. Dealers contact Distributor for technical support, Distributors contact factory for technical support.

OVERVOLTAGE – FAULT CODE 12

⚠WARNING *Some genset service procedures present hazards that can result in severe personal injury or death. Only trained and experienced persons with knowledge of fuels, electricity, and machinery hazards should perform genset service. See Safety Precautions.*

Logic: Instantaneous Fault – AC voltage S1–S2 greater than 150 VAC

Delayed Fault – AC voltage S1–S2 greater than 138 VAC, but less than 150 VAC for 3 continuous minutes

Possible Causes: Genset loads, Inverter/Charger, wire connections, AC sense transformer, windings

Diagnosis & Repair:

1. Verify that Last Fault is FC 12: Yes, continue diagnosis; No, troubleshoot actual last fault.
2. Measure AC voltage.
3. Measure AC frequency while changing engine rpm to determine if frequency response matches engine rpm response: repair damaged generator drive system as necessary.
4. Cycle loads to determine if a particular load causes fault: diagnose faulty load as necessary.
5. Determine Inverter/Charger battery charge rate (typical default is 80 percent): if adjustable reduce to 30 percent.
6. Verify balanced loads in 120/240 VAC applications: balance loads within 10 percent line-to-line as required.
7. **HGJAD only** – Run genset in Engine Run Only mode and externally excite field F1–F2 with 12 VDC or 24 VDC and measure main and quadrature winding AC output.
8. **Non EFI** – If the genset will not stay running measure genset frequency, quadrature winding and main winding voltages using Break-Out Tool 420–0603 and Instruction Sheet R1098.
9. Remove connector P1 from control and re-install and try to start genset: inspect, repair or replace P1 connector pins as necessary.
10. Measure field, quadrature and main winding resistance: clean slip rings, replace brushes, repair harness and replace rotor or stator as necessary.
11. Measure field, quadrature and main winding resistance to ground: clean slip rings, replace brushes, repair harness and replace rotor or stator as necessary.
12. Measure field, quadrature and main winding resistance to each other: clean slip rings, replace brushes, repair harness and replace rotor or stator as necessary.
13. Check brush alignment per PSB-682a.
14. Dealers contact Distributor for technical support, Distributors contact factory for technical support.

UNDERVOLTAGE – FAULT CODE 13

⚠WARNING *Some genset service procedures present hazards that can result in severe personal injury or death. Only trained and experienced persons with knowledge of fuels, electricity, and machinery hazards should perform genset service. See Safety Precautions.*

Logic: AC voltage S1–S2 less than 108 VAC for 5 continuous seconds

Possible Causes: Genset loads, Inverter/Charger, wire connections, generator drive system, windings, AC sense transformer, windings

Diagnosis & Repair:

1. Verify that Last Fault is FC 13: Yes, continue diagnosis; No, troubleshoot actual last fault.
2. Measure AC voltage.
3. Measure AC voltage in and out of sense transformer (if so equipped): repair wire connection, replace sense transformer as necessary.
4. Measure AC frequency while changing engine rpm to determine if frequency response matches engine rpm response: repair damaged generator drive system as necessary.
5. Cycle loads to determine if a particular load will cause fault: diagnose faulty load as necessary.
6. Determine battery charge rate (typical default is 80 percent): if adjustable reduce to 30 percent.
7. Verify balanced loads in 120/240 VAC applications: balance loads within 10 percent line-to-line as required.
8. **HGJAD only** – Run genset in Engine Run Only mode and externally excite field F1–F2 with 12 VDC or 24 VDC and measure main and quadrature winding AC output.
9. **Non EFI** – If the genset will not stay running measure genset frequency, quadrature winding and main winding voltages using Break-Out Tool 420–0603 and Instruction Sheet R1098.
10. Remove connector P1 from control and re-install and try to start genset: inspect, repair or replace P1 connector pins as necessary.
11. Measure field, quadrature and main winding resistance: clean slip rings, replace brushes, repair harness and replace rotor or stator as necessary.
12. Measure field, quadrature and main winding resistance to ground: clean slip rings, replace brushes, repair harness and replace rotor or stator as necessary.
13. Measure field, quadrature and main winding resistance to each other: clean slip rings, replace brushes, repair harness and replace rotor or stator as necessary.
14. Check brush alignment per PSB-682a.
15. Dealers contact Distributor for technical support, Distributors contact factory for technical support.

OVERFREQUENCY – FAULT CODE 14

⚠️WARNING *Some genset service procedures present hazards that can result in severe personal injury or death. Only trained and experienced persons with knowledge of fuels, electricity, and machinery hazards should perform genset service. See Safety Precautions.*

Logic: Instantaneous Fault – Frequency greater than 70Hz

Delayed Fault – Frequency greater than 66Hz, but less than 70Hz, for 3 continuous seconds

Possible Causes: Genset loads, Inverter/Charger, engine governor function, fuel supply, air fuel mixture, exhaust system, choke, demand regulator, carburetor, generator drive system, generator windings, ignition, wire connections

Diagnosis & Repair:

1. Verify that Last Fault is FC 14: Yes, continue diagnosis; No, troubleshoot actual last fault.
2. Measure AC current while running genset with vehicle loads: identify faulty or short cycling loads.
3. Determine battery charge rate (typical default is 80 percent): if adjustable reduce to 30 percent.
4. Measure genset load capability with shop load bank (derate for altitude and temperature as necessary).
5. Measure genset frequency and droop while running.
6. Measure AC frequency while changing engine rpm to determine if frequency response matches engine rpm response: repair damaged generator drive system as necessary.
7. Disconnect genset control P1 connector, verify P1 pins are fully inserted and inspect pin condition per PSB-676: insert, repair or replace pins as necessary.
8. Reconnect P1 connector and test run genset for fault occurrence: repair or replace pins in connector as necessary.
9. Check all grounds and neutral leads for looseness at battery, genset, inverter/converter; run genset on separate battery: tighten or replace terminals and leads as necessary.
10. Check air filter cleanliness; replace air filter as necessary.
11. Check for blocked or damaged exhaust system: repair or replace exhaust components as necessary.
12. Verify P1-29 (HGJAD, E, F Models; unused Hz select option prior to 2004) is not grounded: remove lead termination, tape and isolate.
13. **HGJAD only** – Run genset in Engine Run Only and externally excite field F1-F2 with 12 VDC or 24 VDC and measure main and quadrature winding AC output.
14. **Non EFI** – If the genset will not stay running measure genset frequency, quadrature winding and main winding voltages using Break-Out Tool 420-0603 and Instruction Sheet R1098.
15. **All Gasoline Models**
 - A. Vapor lock may occur in high ambient temperatures: operate in ambients at less than 120°F; verify proper installation to prevent air recirculation; correct as necessary.
 - B. Measure steady DC voltage at fuel pump while genset is cranking: repair wiring as necessary.
 - C. Try to start genset on shop fuel supply: verify tank level and fuel line condition in vehicle.

16. All Gasoline Carburetor Models

- A. Verify carburetor altitude setting: readjust as necessary.
- B. Verify choke operation, setting, linkage, vacuum pull off assembly and sustain valve: readjust, repair or replace as necessary.
- C. Measure fuel pump pressure/flow: replace fuel filter or fuel pump as necessary.
- D. Inspect carburetor butterfly for binding: replace carburetor as necessary.

17. All Gasoline EFI Models

- A. Inspect throttle body for binding or damage: replace as necessary.
- B. Measure fuel pump pressure/flow: replace fuel filter, pressure regulator or fuel pump as necessary.

18. Propane Models

- A. When ambient temperatures are less than 40°F vapor-withdrawal Propane tanks should be at least half full to provide proper vaporization rate.
 - B. Propane having more than 2.5 percent Butane will not vaporize in ambients at less than 32°F; use HD-5 grade Propane.
 - C. Measure steady DC voltage at fuel solenoid while genset is running; repair wiring as necessary.
 - D. Verify clear vent hose.
 - E. Run genset on shop fuel supply; verify tank level and fuel line condition in vehicle.
 - F. Check genset fuel lines for damage: replace fuel line as required.
 - G. Measure regulator lock off pressure.
19. Check governor, actuator, linkage and spring for debris, damage and looseness: readjust and repair as necessary.
20. Measure field, quadrature and main winding resistance: clean slip rings, replace brushes, repair harness and replace rotor or stator as necessary.
21. Measure field, quadrature and main winding resistance to ground: clean slip rings, replace brushes, repair harness and replace rotor or stator as necessary.
22. Measure field, quadrature and main winding resistance to each other: clean slip rings, replace brushes, repair harness and replace rotor or stator as necessary.
23. Check brush alignment per PSB-682a.
24. Verify that spark plug cables are secure on spark plugs: reconnect or replace as necessary.
25. Inspect ignition kill leads in harness and at connector P1: repair or replace lead, terminal or pins as necessary.
26. Test Magnetos:
- A. Disconnect Connector P1.
 - B. Connect positive(+) meter lead to chassis ground.
 - C. **HGJAA, D, E, F** – Measure continuity to negative lead at pin P1-4 and P1-5: replace magnetos as necessary.
 - D. **HGJAB, C** – Measure continuity to negative lead at pin P1-15 and P1-20: replace magnetos as necessary.
27. Measure spark plug gap: set gap or replace spark plugs as necessary.
28. Verify ignition spark condition.
29. Inspect spark plug cables, kill lead terminal at magneto and measure magneto air gap: replace terminals, set gap or replace magnetos as necessary.
30. Measure temperature of air intake and temperature rise across genset; remove blockage or prevent air recirculation.
31. Dealers contact Distributor for technical support, Distributors contact factory for technical support.

UNDERFREQUENCY – FAULT CODE 15

⚠️WARNING *Some genset service procedures present hazards that can result in severe personal injury or death. Only trained and experienced persons with knowledge of fuels, electricity, and machinery hazards should perform genset service. See Safety Precautions.*

Logic: Carburetor Models – Frequency less than 54Hz for 30 continuous seconds
EFI Models – Frequency less than 54Hz for 8 continuous seconds

Possible causes: Genset loads, Inverter/Charger, engine governor function, fuel supply, air fuel mixture, exhaust system, choke, demand regulator, carburetor, generator drive system, generator windings, ignition, wire connections

Diagnosis & Repair:

1. Verify that Last Fault is FC 15: Yes, continue diagnosis; No, troubleshoot actual last fault.
2. Measure AC current while running genset with vehicle loads: identify faulty or short cycling loads.
3. Determine battery charge rate (typical default is 80 percent): if adjustable reduce to 30 percent.
4. Measure genset load capability with shop load bank (derate for altitude and temperature as necessary).
5. Measure genset frequency and droop while running.
6. Measure AC frequency while changing engine rpm to determine if frequency response matches engine rpm response: repair damaged generator drive system as necessary.
7. Disconnect genset control P1 connector, verify P1 pins are fully inserted and inspect pin condition per PSB-676: insert, repair or replace pins as necessary.
8. Reconnect P1 connector and test run genset for fault occurrence: repair or replace pins in connector as necessary.
9. Check air filter cleanliness; replace air filter as necessary.
10. Check for blocked or damaged exhaust system: repair or replace exhaust components as necessary.
11. **HGJAD only** – Run genset in Engine Run Only and externally excite field with 12 VDC or 24 VDC and measure main and quadrature winding AC output.
12. **Non EFI only** – If the genset will not stay running measure genset frequency, quadrature winding and main winding voltages using Break-Out Tool 420-0603 and Instruction Sheet R1098.
13. **All Gasoline Models**
 - A. Vapor lock may occur in high ambient temperatures: operate in ambients at less than 120°F; verify proper installation to prevent air recirculation; correct as necessary.
 - B. Measure steady DC voltage at fuel pump while genset is cranking: repair wiring as necessary.
 - C. Try to start genset on shop fuel supply: verify tank level and fuel line condition in vehicle.
14. **All Gasoline Carburetor Models**
 - A. Verify carburetor altitude setting: readjust as necessary.
 - B. Verify choke operation, setting, linkage, vacuum pull off assembly and sustain valve: readjust, repair or replace as necessary.
 - C. Measure fuel pump pressure/flow: replace fuel filter or fuel pump as necessary.
 - D. Inspect carburetor butterfly for binding: replace carburetor as necessary.

15. All Gasoline EFI Models

- A. Inspect throttle body for binding or damage: replace as necessary.
- B. Measure fuel pump pressure/flow: replace fuel filter, pressure regulator or fuel pump as necessary.

16. Propane Models

- A. When ambient temperatures are less than 40°F vapor-withdrawal Propane tanks should be at least half full to provide proper vaporization rate.
 - B. Propane having more than 2.5 percent Butane will not vaporize in ambients at less than 32°F; use HD-5 grade Propane.
 - C. Measure steady DC voltage at fuel solenoid while genset is running; repair wiring as necessary.
 - D. Verify clear vent hose.
 - E. Run genset on shop fuel supply; verify tank level and fuel line condition in vehicle.
 - F. Check genset fuel lines for damage: replace fuel line as required.
 - G. Measure regulator lock off pressure.
17. Check governor, actuator, linkage and spring for debris, damage and looseness: readjust and repair as necessary.
18. Measure field, quadrature and main winding resistance: clean slip rings, replace brushes, repair harness and replace rotor or stator as necessary.
19. Measure field, quadrature and main winding resistance to ground: clean slip rings, replace brushes, repair harness and replace rotor or stator as necessary.
20. Measure field, quadrature and main winding resistance to each other: clean slip rings, replace brushes, repair harness and replace rotor or stator as necessary.
21. Check brush alignment per PSB-682a.
22. Verify that spark plug cables are secure on spark plugs: reconnect or replace as necessary.
23. Inspect ignition kill leads in harness and at connector P1: repair or replace lead, terminal or pins as necessary.
24. Test Magnetos:
- A. Disconnect Connector P1.
 - B. Connect positive(+) meter lead to chassis ground.
 - C. **HGJAA, D, E, F** – Measure continuity to negative lead at pin P1-4 and P1-5: replace magnetos as necessary.
 - D. **HGJAB, C** – Measure continuity to negative lead at pin P1-15 and P1-20: replace magnetos as necessary.
25. Measure spark plug gap: set gap or replace spark plugs as necessary.
26. Verify ignition spark condition.
27. Inspect spark plug lead, kill lead terminal at magneto and measure magneto air gap: replace terminals, set gap or replace magnetos as necessary.
28. Measure temperature of air intake and temperature rise across genset; remove blockage or prevent air recirculation.
29. Dealers contact Distributor for technical support, Distributors contact factory for technical support.

FUEL PUMP FAULT – FAULT CODE 17

⚠WARNING *Some genset service procedures present hazards that can result in severe personal injury or death. Only trained and experienced persons with knowledge of fuels, electricity, and machinery hazards should perform genset service. See Safety Precautions.*

Logic: Only Active Prior to 2001 – Open fuel pump circuit at control

Possible Causes: Wire connections, harness leads, faulty fuel pump

Diagnosis & Repair:

1. Verify that Last Fault is FC 17: Yes, continue diagnosis; No, troubleshoot actual last fault.
2. Verify fuel pump operation in prime mode, if pump operates fault condition has been cleared verify harness connections, no further troubleshooting.
3. **HGJAA, D** Check continuity across fuse F1.
4. Disconnect genset control P1 connector, verify P1 pins are fully inserted and inspect pin condition per PSB-676: insert, repair or replace pins as necessary.
5. Reconnect P1 connector, prime genset to verify pump operation and test run genset for fault occurrence.
6. Measure continuity between E2 fuel pump leads; replace terminals or fuel pump as necessary.
7. Measure voltage between fuel pump E2 + and ground while priming; replace terminals, harness leads or control as necessary.

GOVERNOR ACTUATOR (EFI ONLY) – FAULT CODE 19

⚠WARNING *Some genset service procedures present hazards that can result in severe personal injury or death. Only trained and experienced persons with knowledge of fuels, electricity, and machinery hazards should perform genset service. See Safety Precautions.*

Logic: Shorted or open connection between governor leads after pressing start

Possible causes: Wire connections, P1-17, governor actuator

Diagnosis & Repair:

1. Verify that Last Fault is FC 19: Yes, continue diagnosis; No, troubleshoot actual last fault.
2. Disconnect genset control P1 connector, verify P1 pins are fully inserted and inspect pin condition per PSB-676: insert, repair or replace pins as necessary.
3. Reconnect P1 connector and test run genset for fault occurrence: repair or replace pins in connector as necessary.
4. P1-17 open to ground on EFI Models: ground lead as required for carburetor configuration.
5. Verify actuator function by applying DC voltage to terminals: replace actuator as necessary.
6. Measure resistance between actuator terminals; repair or replace connections as necessary, replace governor actuator.
7. Measure continuity between P1-28 and actuator lead; repair or replace terminals and leads as necessary.
8. Measure DC voltage at actuator while starting: replace controller as necessary.

GOVERNOR ACTUATOR OVERLOAD (EFI ONLY) – FAULT CODE 22

⚠WARNING *Some genset service procedures present hazards that can result in severe personal injury or death. Only trained and experienced persons with knowledge of fuels, electricity, and machinery hazards should perform genset service. See Safety Precautions.*

Logic: Only active Prior to 2001 – Maximum governor output (PWM) for 10 continuous seconds

Possible causes: Genset loads, Inverter/Charger, wire connections, fuel supply, air fuel mixture, exhaust system, governor actuator, ignition system

Diagnosis & Repair:

1. Verify that Last Fault is FC 22: Yes, continue diagnosis; No, troubleshoot actual last fault.
2. Measure AC current while running genset with vehicle loads: identify faulty or short cycling loads or reduce vehicle loads as necessary.
3. Determine battery charge rate (typical default is 80 percent): if adjustable reduce to 30 percent.
4. Measure genset load capability with shop load bank (derate for altitude and temperature as necessary).
5. Measure AC frequency and droop while running.
6. Measure AC frequency while changing engine rpm to determine if frequency response matches engine rpm response: repair damaged generator drive system as necessary.
7. Disconnect genset control P1 connector, verify P1 pins are fully inserted and inspect pin condition per PSB-676: insert, repair or replace pins as necessary.
8. Reconnect P1 connector and test run genset for fault occurrence: repair or replace pins in connector as necessary.
9. Check air filter cleanliness; replace air filter as necessary.
10. Check intake manifold and gaskets for air leaks: tighten fasteners and replace gaskets and manifold as necessary.
11. Check for blocked or damaged exhaust system: repair or replace exhaust components as necessary.
12. Measure fuel pump pressure/flow: replace fuel filter, pressure regulator or fuel pump as necessary.
13. Verify actuator function by applying DC voltage to terminals: replace actuator as necessary.
14. Check throttle body for binding; inspect spring for dirt and debris: clean spring, replace throttle body as necessary.
15. Verify that spark plug cables are secure on spark plugs: reconnect or replace as necessary.
16. Inspect ignition kill leads in harness and at connector P1: repair or replace lead, terminal or pins as necessary.
17. Test Magnetos:
 - A. Disconnect Connector P1.
 - B. Connect positive(+) meter lead to chassis ground.
 - C. **HGJAA, D, E, F** – Measure continuity to negative lead at pin P1-4 and P1-5: replace magnetos as necessary.
 - D. **HGJAB, C** – Measure continuity to negative lead at pin P1-15 and P1-20: replace magnetos as necessary.
18. Measure spark plug gap: set gap or replace spark plugs as necessary.
19. Verify ignition spark condition.
20. Inspect spark plug cables, kill lead terminal at magneto and measure magneto air gap: replace terminals, set gap or replace magnetos as necessary.
21. Dealers contact Distributor for technical support, Distributors contact factory for technical support.

OIL PRESSURE SWITCH FAULT – FAULT CODE 23

⚠WARNING *Some genset service procedures present hazards that can result in severe personal injury or death. Only trained and experienced persons with knowledge of fuels, electricity, and machinery hazards should perform genset service. See Safety Precautions.*

Logic: Only Active Prior to 2001 – Continuous open on oil pressure switch input before cranking

Possible Causes: Wire connections, faulty switch

Diagnosis & Repair:

1. Verify that Last Fault is FC 23: Yes, continue diagnosis; No, troubleshoot actual last fault.
2. Verify harness lead is connected to switch: repair or replace terminal as necessary.
3. Disconnect genset control P1 connector, verify P1 pins are fully inserted and inspect pin condition per: insert, repair or replace pins as necessary.
4. Reconnect P1 connector and test run genset for fault occurrence.
5. Measure continuity to ground at switch and through harness at P1 connector: replace switch, repair or replace harness as necessary.

VOLTAGE SENSE LOST – FAULT CODE 27

⚠WARNING *Some genset service procedures present hazards that can result in severe personal injury or death. Only trained and experienced persons with knowledge of fuels, electricity, and machinery hazards should perform genset service. See Safety Precautions.*

Logic: No Sense Voltage (0 VAC across S1–S2) for 1 continuous second after start disconnect

Possible Causes: Genset loads, Inverter/Charger, VAC sense transformer, engine governor function, fuel supply, choke, demand regulator, carburetor, generator windings, ignition, wire connections, temperature

Diagnosis & Repair:

1. Verify that Last Fault is FC 27: Yes, continue diagnosis; No, troubleshoot actual last fault.
2. Measure AC voltage.
3. Determine battery charge rate (typical default is 80 percent): if adjustable reduce to 30 percent.
4. Disconnect genset control P1 connector, verify P1 pins are fully inserted and inspect pin condition per PSB–676: insert, repair or replace pins as necessary.
5. Reconnect P1 connector and test run genset for fault occurrence: repair or replace pins in connector as necessary.
6. Check air filter cleanliness; replace air filter as necessary.
7. Check for blocked or damaged exhaust system: repair or replace exhaust components as necessary.
8. **HGJAD only** – Run genset in Engine Run Only and externally excite field with 12 VDC or 24 VDC and measure main and quadrature winding AC output.
9. **Non EFI only** – If the genset will not stay running measure genset frequency, quadrature winding and main winding voltages using Break-Out Tool 420–0603 and Instruction Sheet R1098.

10. All Gasoline Models

- A. Vapor lock may occur in high ambient temperatures: operate in ambients at less than 120°F; verify proper installation to prevent air recirculation; correct as necessary.
- B. Measure steady DC voltage at fuel pump while genset is cranking: repair wiring as necessary.
- C. Try to start genset on shop fuel supply: verify tank level and fuel line condition in vehicle.

11. All Gasoline Carburetor Models

- A. Verify carburetor altitude setting: readjust as necessary.
- B. Verify choke operation, setting, linkage, vacuum pull off assembly and sustain valve: readjust, repair or replace as necessary.
- C. Measure fuel pump pressure/flow: replace fuel filter or fuel pump as necessary.
- D. Inspect carburetor butterfly for binding: replace carburetor as necessary.

12. All Gasoline EFI Models

- A. Inspect throttle body for binding or damage: replace as necessary.
- B. Measure fuel pump pressure/flow: replace fuel filter, pressure regulator or fuel pump as necessary.

13. Propane Models

- A. When ambient temperatures are less than 40°F vapor-withdrawal Propane tanks should be at least half full to provide proper vaporization rate.
- B. Propane having more than 2.5 percent Butane will not vaporize in ambients at less than 32°F; use HD-5 grade Propane.
- C. Measure steady DC voltage at fuel solenoid while genset is running; repair wiring as necessary.
- D. Verify clear vent hose.
- E. Run genset on shop fuel supply; verify tank level and fuel line condition in vehicle.
- F. Check genset fuel lines for damage: replace fuel line as required.
- G. Measure regulator lock off pressure.

- 14. Check governor, actuator, linkage and spring for debris, damage and looseness: readjust and repair as necessary.
- 15. Measure field, quadrature and main winding resistance: clean slip rings, replace brushes, repair harness and replace rotor or stator as necessary.
- 16. Measure field, quadrature and main winding resistance to ground: clean slip rings, replace brushes, repair harness and replace rotor or stator as necessary.
- 17. Measure field, quadrature and main winding resistance to each other: clean slip rings, replace brushes, repair harness and replace rotor or stator as necessary.
- 18. Check brush alignment.
- 19. Verify that spark plug cables are secure on spark plugs: reconnect or replace as necessary.
- 20. Inspect ignition kill leads in harness and at connector P1: repair or replace lead, terminal or pins as necessary.

21. Test Magnetos:

- A. Disconnect Connector P1.
- B. Connect positive(+) meter lead to chassis ground.
- C. **HGJAA, D, E, F** – Measure continuity to negative lead at pin P1–4 and P1–5: replace magnetos as necessary.
- D. **HGJAB, C** – Measure continuity to negative lead at pin P1–15 and P1–20: replace magnetos as necessary.

22. Measure spark plug gap: set gap or replace spark plugs as necessary.

23. Verify ignition spark condition.

24. Inspect spark plug lead, kill lead terminal at magneto and measure magneto air gap: replace terminals, set gap or replace magnetos as necessary.

25. Measure temperature of air intake and temperature rise across genset; remove blockage or prevent air recirculation.

26. Dealers contact Distributor for technical support, Distributors contact factory for technical support.

HIGH BATTERY VOLTAGE – FAULT CODE 29

⚠WARNING *Some genset service procedures present hazards that can result in severe personal injury or death. Only trained and experienced persons with knowledge of fuels, electricity, and machinery hazards should perform genset service. See Safety Precautions.*

Logic: DC voltage to controller greater than 19 VDC when pressing start or stop

Possible Causes: Incorrect battery configuration, wire damage, faulty charger, control

Diagnosis & Repair:

- 1. Verify that Last Fault is FC 29: Yes, continue diagnosis; No, troubleshoot actual last fault.
- 2. Measure DC voltage at battery, genset and connector P1: reconnect battery or repair wiring as necessary.
- 3. Measure DC voltage with battery charger on: reduce boost charge rate or diagnose faulty charger as necessary.
- 4. If genset shares batteries with propulsion engine, check for fault using shop battery (voltage spike may cause fault): diagnose fault or voltage spikes from propulsion engine charging system.
- 5. Disconnect genset control P1 connector, verify P1 pins are fully inserted and inspect pin condition per PSB–676: insert, repair or replace pins as necessary.
- 6. Reconnect P1 connector and test run genset for fault occurrence: replace controller.

OVERSPEED FAULT (HGJAD, E, F MODELS ONLY) – FAULT CODE 31

⚠WARNING *Some genset service procedures present hazards that can result in severe personal injury or death. Only trained and experienced persons with knowledge of fuels, electricity, and machinery hazards should perform genset service. See Safety Precautions.*

Logic: 5kW Engine Run Only mode –Engine RPM via ignition pulse greater than 2880rpm
7kW Engine Run Only mode –Engine RPM via ignition pulse greater than 3360rpm

Possible Causes: Engine governor function, fuel supply, air fuel mixture, exhaust system, choke, demand regulator, carburetor, generator drive system, ignition, wire connections

Diagnosis & Repair:

1. Verify that Last Fault is FC 31: Yes, continue diagnosis; No, troubleshoot actual last fault.
2. Measure genset frequency and droop while running.
3. Measure AC frequency while changing engine rpm to determine if frequency response matches engine rpm response: repair damaged generator drive system as necessary.
4. Disconnect genset control P1 connector, verify P1 pins are fully inserted and inspect pin condition per PSB-676: insert, repair or replace pins as necessary.
5. Reconnect P1 connector and test run genset for fault occurrence: repair or replace pins in connector as necessary.
6. Check air filter cleanliness; replace air filter as necessary.
7. Check for blocked or damaged exhaust system: repair or replace exhaust components as necessary.
8. **HGJAD only** – Run genset in Engine Run Only and externally excite field F1–F2 with 12 VDC or 24 VDC and measure AC frequency.
9. **Non EFI** – If the genset will not stay running measure AC frequency using Break-Out Tool 420-0603 and Instruction Sheet R1098.
10. **All Gasoline Models**
 - A. Vapor lock may occur in high ambient temperatures: operate in ambients at less than 120°F; verify proper installation to prevent air recirculation; correct as necessary.
 - B. Measure steady DC voltage at fuel pump while genset is cranking: repair wiring as necessary.
 - C. Try to start genset on shop fuel supply: verify tank level and fuel line condition in vehicle.
11. **All Gasoline Carburetor Models**
 - A. Verify carburetor altitude setting: readjust as necessary.
 - B. Verify choke operation, setting, linkage, vacuum pull off assembly and sustain valve: readjust, repair or replace as necessary.
 - C. Measure fuel pump pressure/flow: replace fuel filter or fuel pump as necessary.
 - D. Inspect carburetor butterfly for binding: replace carburetor as necessary.
12. **All Gasoline EFI Models**
 - A. Inspect throttle body for binding or damage: replace as necessary.
 - B. Measure fuel pump pressure/flow: replace fuel filter, pressure regulator or fuel pump as necessary.

13. Propane Models

- A. When ambient temperatures are less than 40°F vapor-withdrawal Propane tanks should be at least half full to provide proper vaporization rate.
 - B. Propane having more than 2.5 percent Butane will not vaporize in ambients at less than 32°F; use HD-5 grade Propane.
 - C. Measure steady DC voltage at fuel solenoid while genset is running; repair wiring as necessary.
 - D. Verify clear vent hose.
 - E. Run genset on shop fuel supply; verify tank level and fuel line condition in vehicle.
 - F. Check genset fuel lines for damage: replace fuel line as required.
 - G. Measure regulator lock off pressure.
14. Check governor, actuator, linkage and spring for debris, damage and looseness: readjust and repair as necessary.
15. Verify that spark plug cables are secure on spark plugs: reconnect or replace as necessary.
16. Inspect ignition kill leads in harness and at connector P1: repair or replace lead, terminal or pins as necessary.
17. Test Magnetos
- A. Disconnect Connector P1.
 - B. Connect positive(+) meter lead to chassis ground.
 - C. Measure continuity to negative lead at pin P1-4 and P1-5: replace magnetos as necessary.
18. Measure spark plug gap: set gap or replace spark plugs as necessary.
19. Verify ignition spark condition.
20. Inspect spark plug lead, kill lead terminal at magneto and measure magneto air gap: replace terminals, set gap or replace magnetos as necessary.
21. Measure temperature of air intake and temperature rise across genset; remove blockage or prevent air recirculation.
22. Dealers contact Distributor for technical support, Distributors contact factory for technical support.

LOW CRANKING SPEED SENSE – FAULT CODE 32

⚠WARNING *Some genset service procedures present hazards that can result in severe personal injury or death. Only trained and experienced persons with knowledge of fuels, electricity, and machinery hazards should perform genset service. See Safety Precautions.*

Logic:

Prior to 2003 – quadrature frequency less than 1.7Hz for 2 continuous seconds after pressing start.

After 2003 – quadrature frequency less than 1.7Hz for 12 continuous seconds after pressing start

Model HGJAD – quadrature frequency less than 1.7Hz & Engine RPM 0 for 12 continuous seconds after pressing start

Possible Causes: Cylinder at TDC, fuel supply, air fuel mixture, exhaust system, starter, choke, demand regulator, carburetor, generator drive system, generator windings, ignition, wire connections

Diagnosis & Repair:

1. Verify that Last Fault is FC 32: Yes, continue diagnosis; No, troubleshoot actual last fault.
2. Measure battery voltage at battery and genset: recharge or replace battery as necessary.
3. Verify engine rotation manually: repair engine damage as necessary.
4. Disconnect genset control P1 connector, verify P1 pins are fully inserted and inspect pin condition per PSB-676: insert, repair or replace pins as necessary.
5. Reconnect P1 connector and test run genset for fault occurrence: repair or replace pins in connector as necessary.
6. Measure DC voltage at starter during start attempt: repair wire connections, replace start solenoid and starter as necessary.
7. Check air filter cleanliness; replace air filter as necessary.
8. Check for blocked or damaged exhaust system: repair or replace exhaust components as necessary.
9. **HGJAD only** – Run genset in Engine Run Only and externally excite field F1-F2 with 12 VDC or 24 VDC and measure main and quadrature winding AC output.
10. **Non EFI** – Verify genset operation and outputs with Break-Out Tool 420-0603 and Instruction Sheet R1098.
11. Measure AC frequency while changing engine rpm to determine if frequency response matches engine rpm response: repair damaged generator drive system as necessary.
12. **All Gasoline Models**
 - A. Vapor lock may occur in high ambient temperatures: operate in ambients at less than 120°F; verify proper installation to prevent air recirculation; correct as necessary.
 - B. Measure steady DC voltage at fuel pump while genset is cranking: repair wiring as necessary.
 - C. Try to start genset on shop fuel supply: verify tank level and fuel line condition in vehicle.
13. **All Gasoline Carburetor Models**
 - A. Verify carburetor altitude setting: readjust as necessary.
 - B. Verify choke operation, setting, linkage, vacuum pull off assembly and sustain valve: readjust, repair or replace as necessary.
 - C. Measure fuel pump pressure/flow: replace fuel filter or fuel pump as necessary.
 - D. Inspect carburetor butterfly for binding: replace carburetor as necessary.

14. All Gasoline EFI Models

- A. Inspect throttle body for binding or damage: replace as necessary.
- B. Measure fuel pump pressure/flow: replace fuel filter, pressure regulator or fuel pump as necessary.

15. Propane Models

- A. When ambient temperatures are less than 40°F vapor-withdrawal Propane tanks should be at least half full to provide proper vaporization rate.
 - B. Propane having more than 2.5 percent Butane will not vaporize in ambients at less than 32°F; use HD-5 grade Propane.
 - C. Measure steady DC voltage at fuel solenoid while genset is running; repair wiring as necessary.
 - D. Verify clear vent hose.
 - E. Run genset on shop fuel supply; verify tank level and fuel line condition in vehicle.
 - F. Check genset fuel lines for damage: replace fuel line as required.
 - G. Measure regulator lock off pressure.
16. Check governor, actuator, linkage and spring for debris, damage and looseness: readjust and repair as necessary.
17. Verify that spark plug cables are secure on spark plugs: reconnect or replace as necessary.
18. Inspect ignition kill leads in harness and at connector P1: repair or replace lead, terminal or pins as necessary.
19. Test Magnetos
- A. Disconnect Connector P1.
 - B. Connect positive(+) meter lead to chassis ground.
 - C. **HGJAA, D, E, F** – Measure continuity to negative lead at pin P1-4 and P1-5: replace magnetos as necessary.
 - D. **HGJAB, C** – Measure continuity to negative lead at pin P1-15 and P1-20: replace magnetos as necessary.
20. Measure spark plug gap: set gap or replace spark plugs as necessary.
21. Verify ignition spark condition.
22. Inspect spark plug lead, kill lead terminal at magneto and measure magneto air gap: replace terminals, set gap or replace magnetos as necessary.
23. Measure temperature of air intake and temperature rise across genset; remove blockage or prevent air recirculation.
24. Dealers contact Distributor for technical support, Distributors contact factory for technical support.

FAULT CODE 33 – FAULT CODE 33

⚠WARNING *Some genset service procedures present hazards that can result in severe personal injury or death. Only trained and experienced persons with knowledge of fuels, electricity, and machinery hazards should perform genset service. See Safety Precautions.*

Logic: Single-Digit Fault to indicate shutdown due to Two-Digit Fault Code

Possible Cause: Fault Code 3 interpreted as a non-assigned Fault Code 33

Diagnosis & Repair:

1. Verify that Last Fault is FC 3 Yes, continue diagnosis; No, troubleshoot actual last fault.
2. While LED is flashing three times press stop once (1 second duration): trouble shoot Two-Digit Fault Code.

CONTROL CARD FAILURE – FAULT CODE 35

⚠ WARNING *Some genset service procedures present hazards that can result in severe personal injury or death. Only trained and experienced persons with knowledge of fuels, electricity, and machinery hazards should perform genset service. See Safety Precautions.*

Logic: EEPROM (programming variables) error during self test

Possible Causes: Faulty program

Diagnosis & Solution:

1. Verify that Last Fault is FC 35: Yes, continue diagnosis; No, troubleshoot actual last fault.
2. Replace control.

GENSET STOPPED WITHOUT FAULT CONDITION – FAULT CODE 36

⚠ WARNING *Some genset service procedures present hazards that can result in severe personal injury or death. Only trained and experienced persons with knowledge of fuels, electricity, and machinery hazards should perform genset service. See Safety Precautions.*



14. All Gasoline Models

- A. Vapor lock may occur in high ambient temperatures: operate in ambients at less than 120°F; verify proper installation to prevent air recirculation; correct as necessary.
- B. Measure steady DC voltage at fuel pump while genset is cranking: repair wiring as necessary.
- C. Try to start genset on shop fuel supply: verify tank level and fuel line condition in vehicle.

15. All Gasoline Carburetor Models

- A. Verify carburetor altitude setting: readjust as necessary.
- B. Verify choke operation, setting, linkage, vacuum pull off assembly and sustain valve: readjust, repair or replace as necessary.
- C. Measure fuel pump pressure/flow: replace fuel filter or fuel pump as necessary.
- D. Inspect carburetor butterfly for binding: replace carburetor as necessary.

16. All Gasoline EFI Models

- A. Inspect throttle body for binding or damage: replace as necessary.
- B. Measure fuel pump pressure/flow: replace fuel filter, pressure regulator or fuel pump as necessary.

17. Propane Models

- A. When ambient temperatures are less than 40°F vapor-withdrawal Propane tanks should be at least half full to provide proper vaporization rate.
- B. Propane having more than 2.5 percent Butane will not vaporize in ambients at less than 32°F; use HD-5 grade Propane.
- C. Measure steady DC voltage at fuel solenoid while genset is running; repair wiring as necessary.
- D. Verify clear vent hose.
- E. Run genset on shop fuel supply; verify tank level and fuel line condition in vehicle.
- F. Check genset fuel lines for damage: replace fuel line as required.
- G. Measure regulator lock off pressure.

18. Check governor, actuator, linkage and spring for debris, damage and looseness: readjust and repair as necessary.

19. Verify that spark plug cables are secure on spark plugs: reconnect or replace as necessary.

20. Inspect ignition kill leads in harness and at connector P1: repair or replace lead, terminal or pins as necessary.

21. Test Magnetos

- A. Disconnect Connector P1.
- B. Connect positive(+) meter lead to chassis ground.
- C. **HGJAA, D, E, F** – Measure continuity to negative lead at pin P1-4 and P1-5: replace magnetos as necessary.
- D. **HGJAB, C** – Measure continuity to negative lead at pin P1-15 and P1-20: replace magnetos as necessary.

22. Measure spark plug gap: set gap or replace spark plugs as necessary.

23. Verify ignition spark condition.

24. Inspect spark plug lead, kill lead terminal at magneto and measure magneto air gap: replace terminals, set gap or replace magnetos as necessary.

25. Measure temperature of air intake and temperature rise across genset; remove blockage or prevent air recirculation.

26. Dealers contact Distributor for technical support, Distributors contact factory for technical support.

INVALID SET CONFIGURATION – FAULT CODE 37

⚠WARNING *Some genset service procedures present hazards that can result in severe personal injury or death. Only trained and experienced persons with knowledge of fuels, electricity, and machinery hazards should perform genset service. See Safety Precautions.*

Logic: Configuration is determined by ratio of quadrature frequency / ignition speed

Possible Causes: Wire connections, windings, ignition system, drive belt slippage, generator drive system

Diagnosis & Repair:

1. Verify that Last Fault is FC 37: Yes, continue diagnosis; No, troubleshoot actual last fault.
2. Alternating FC 37 and FC 47: Magneto gap to wide: reset magneto gap, retest.
3. **HGJAD only** – Run genset in Engine Run Only and externally excite field with 12 VDC or 24 VDC and measure main and quadrature winding AC output.
4. **Non EFI only** – If the genset will not stay running measure genset frequency, quadrature winding and main winding voltages using Break-Out Tool 420–0603 and Instruction Sheet R1098.
5. Measure AC frequency while changing engine rpm to determine if frequency response matches engine rpm response: repair damaged generator drive system as necessary.
6. Measure field, quadrature and main winding resistance: clean slip rings, replace brushes, repair harness and replace rotor or stator as necessary.
7. Measure field, quadrature and main winding resistance to ground: clean slip rings, replace brushes, repair harness and replace rotor or stator as necessary.
8. Measure field, quadrature and main winding resistance to each other: clean slip rings, replace brushes, repair harness and replace rotor or stator as necessary.
9. Check brush alignment per PSB-682a.
10. Verify that spark plug cables are secure on spark plugs: reconnect or replace as necessary.
11. Inspect ignition kill leads in harness and at connector P1: repair or replace lead, terminal or pins as necessary.
12. Test Magnetos
 - A. Disconnect Connector P1.
 - B. Connect positive(+) meter lead to chassis ground.
 - C. **HGJAA, D, E, F** – Measure continuity to negative lead at pin P1–4 and P1–5: replace magnetos as necessary.
 - D. **HGJAB, C** – Measure continuity to negative lead at pin P1–15 and P1–20: replace magnetos as necessary.
13. Measure spark plug gap: set gap or replace spark plugs as necessary.
14. Verify ignition spark condition.
15. Inspect spark plug lead, kill lead terminal at magneto and measure magneto air gap: replace terminals, set gap or replace magnetos as necessary.
16. Dealers contact Distributor for technical support, Distributors contact factory for technical support.

FIELD OVERLOAD (OVERVOLTAGE) – FAULT CODE 38

⚠️WARNING *Some genset service procedures present hazards that can result in severe personal injury or death. Only trained and experienced persons with knowledge of fuels, electricity, and machinery hazards should perform genset service. See Safety Precautions.*

Logic: Field voltage (F1–F1) greater than 150 VDC for 10 continuous seconds

Possible Causes: Loads, Inverter/Charger, windings, fuel supply, governor system

Diagnosis & Repair:

1. Verify that Last Fault is FC 38: Yes, continue diagnosis; No, troubleshoot actual last fault.
2. Measure F1–F2 DC voltage.
3. Measure AC current while running genset with vehicle loads: identify faulty or short cycling loads.
4. Determine battery charge rate (typical default is 80 percent): if adjustable reduce to 30 percent.
5. Disconnect genset control P1 connector, verify P1 pins are fully inserted and inspect pin condition per PSB–676: insert, repair or replace pins as necessary.
6. Reconnect P1 connector and test run genset for fault occurrence: repair or replace pins in connector as necessary.
7. Measure genset load capability with shop load bank (derate for altitude and temperature as necessary).
8. Measure genset frequency and droop while running.
9. Check governor, actuator, linkage and spring for debris, damage and looseness: readjust and repair as necessary.
10. Check air filter cleanliness; replace air filter as necessary.
11. Check for blocked or damaged exhaust system: repair or replace exhaust components as necessary.
12. **All Gasoline Models**
 - A. Vapor lock may occur in high ambient temperatures: operate in ambients at less than 120°F; verify proper installation to prevent air recirculation; correct as necessary.
 - B. Measure steady DC voltage at fuel pump while genset is cranking: repair wiring as necessary.
 - C. Try to start genset on shop fuel supply: verify tank level and fuel line condition in vehicle.
13. **All Gasoline Carburetor Models**
 - A. Verify carburetor altitude setting: readjust as necessary.
 - B. Verify choke operation, setting, linkage, vacuum pull off assembly and sustain valve: readjust, repair or replace as necessary.
 - C. Measure fuel pump pressure/flow: replace fuel filter or fuel pump as necessary.
 - D. Inspect carburetor butterfly for binding: replace carburetor as necessary.
14. **All Gasoline EFI Models**
 - A. Inspect throttle body for binding or damage: replace as necessary.
 - B. Measure fuel pump pressure/flow: replace fuel filter, pressure regulator or fuel pump as necessary.

15. Propane Models

- A. When ambient temperatures are less than 40°F vapor-withdrawal Propane tanks should be at least half full to provide proper vaporization rate.
 - B. Propane having more than 2.5 percent Butane will not vaporize in ambients at less than 32°F; use HD-5 grade Propane.
 - C. Measure steady DC voltage at fuel solenoid while genset is running; repair wiring as necessary.
 - D. Verify clear vent hose.
 - E. Run genset on shop fuel supply; verify tank level and fuel line condition in vehicle.
 - F. Check genset fuel lines for damage: replace fuel line as required.
 - G. Measure regulator lock off pressure.
16. Check governor, actuator, linkage and spring for debris, damage and looseness: readjust and repair as necessary.
 17. **HGJAD only** – Run genset in Engine Run Only and externally excite field F1–F2 with 12 VDC or 24 VDC and measure main and quadrature winding AC output.
 18. **Non EFI** – If the genset will not stay running measure genset frequency, quadrature winding and main winding voltages using Break-Out Tool 420–0603 and Instruction Sheet R1098.
 19. Remove connector P1 from control and re-install and try to start genset: inspect, repair or replace P1 connector pins as necessary.
 20. Measure field, quadrature and main winding resistance: clean slip rings, replace brushes, repair harness and replace rotor or stator as necessary.
 21. Measure field, quadrature and main winding resistance to ground: clean slip rings, replace brushes, repair harness and replace rotor or stator as necessary.
 22. Measure field, quadrature and main winding resistance to each other: clean slip rings, replace brushes, repair harness and replace rotor or stator as necessary.
 23. Check brush alignment per PSB-682a.
 24. Measure temperature of air intake and temperature rise across genset; remove blockage or prevent air recirculation.
 25. Dealers contact Distributor for technical support, Distributors contact factory for technical support.

GENERATOR ROTOR FAULT – FAULT CODE 41

⚠WARNING *Some genset service procedures present hazards that can result in severe personal injury or death. Only trained and experienced persons with knowledge of fuels, electricity, and machinery hazards should perform genset service. See Safety Precautions.*

Logic: Only Active After 2003 – Field Voltage F1–F2 at 0 VDC and Sense Voltage S1–S2 at 0 VAC for 1 continuous second

Possible Causes: Loads, windings, fuel supply

Diagnosis & Repair:

1. Verify that Last Fault is FC 41: Yes, continue diagnosis; No, troubleshoot actual last fault.
2. Measure F1–F2 DC voltage.
3. Measure AC current while running genset with vehicle loads: identify faulty or short cycling loads.
4. Determine battery charge rate (typical default is 80 percent): if adjustable reduce to 30 percent.
5. Disconnect genset control P1 connector, verify P1 pins are fully inserted and inspect pin condition per PSB–676: insert, repair or replace pins as necessary.
6. Reconnect P1 connector and test run genset for fault occurrence: repair or replace pins in connector as necessary.
7. Measure genset load capability with shop load bank (derate for altitude and temperature as necessary).
8. **All Gasoline Models**
 - A. Vapor lock may occur in high ambient temperatures: operate in ambients at less than 120°F; verify proper installation to prevent air recirculation; correct as necessary.
 - B. Measure steady DC voltage at fuel pump while genset is cranking: repair wiring as necessary.
 - C. Try to start genset on shop fuel supply: verify tank level and fuel line condition in vehicle.
9. **All Gasoline Carburetor Models**
 - A. Verify carburetor altitude setting: readjust as necessary.
 - B. Verify choke operation, setting, linkage, vacuum pull off assembly and sustain valve: readjust, repair or replace as necessary.
 - C. Measure fuel pump pressure/flow: replace fuel filter or fuel pump as necessary.
 - D. Inspect carburetor butterfly for binding: replace carburetor as necessary.
10. **All Gasoline EFI Models**
 - A. Inspect throttle body for binding or damage: replace as necessary.
 - B. Measure fuel pump pressure/flow: replace fuel filter, pressure regulator or fuel pump as necessary.
11. **Propane Models**
 - A. When ambient temperatures are less than 40°F vapor-withdrawal Propane tanks should be at least half full to provide proper vaporization rate.
 - B. Propane having more than 2.5 percent Butane will not vaporize in ambients at less than 32°F; use HD–5 grade Propane.
 - C. Measure steady DC voltage at fuel solenoid while genset is running; repair wiring as necessary.
 - D. Verify clear vent hose.

- E. Run genset on shop fuel supply; verify tank level and fuel line condition in vehicle.
 - F. Check genset fuel lines for damage: replace fuel line as required.
 - G. Measure regulator lock off pressure.
12. Check governor, actuator, linkage and spring for debris, damage and looseness: readjust and repair as necessary.
 13. **HGJAD only** – Run genset in Engine Run Only and externally excite field F1–F2 with 12 VDC or 24 VDC and measure main and quadrature winding AC output
 14. **Non EFI** – If the genset will not stay running measure genset frequency, quadrature winding and main winding voltages using Break-Out Tool 420–0603 and Instruction Sheet R1098.
 15. Remove connector P1 from control and re-install and try to start genset: inspect, repair or replace P1 connector pins as necessary.
 16. Measure field, quadrature and main winding resistance: clean slip rings, replace brushes, repair harness and replace rotor or stator as necessary.
 17. Measure field, quadrature and main winding resistance to ground: clean slip rings, replace brushes, repair harness and replace rotor or stator as necessary.
 18. Measure field, quadrature and main winding resistance to each other: clean slip rings, replace brushes, repair harness and replace rotor or stator as necessary.
 19. Check brush alignment per PSB-682a.
 20. Measure temperature of air intake and temperature rise across genset; remove blockage or prevent air recirculation.
 21. Dealers contact Distributor for technical support, Distributors contact factory for technical support.

PROCESSOR FAULT – FAULT CODE 42

⚠WARNING *Some genset service procedures present hazards that can result in severe personal injury or death. Only trained and experienced persons with knowledge of fuels, electricity, and machinery hazards should perform genset service. See Safety Precautions.*

Logic: ROM (programming variables) error during self test

Possible Causes: Faulty program

Diagnosis & Solution:

1. Verify that Last Fault is FC 42: Yes, continue diagnosis; No, troubleshoot actual last fault.
2. Replace control.

PROCESSOR FAULT – FAULT CODE 43

⚠WARNING *Some genset service procedures present hazards that can result in severe personal injury or death. Only trained and experienced persons with knowledge of fuels, electricity, and machinery hazards should perform genset service. See Safety Precautions.*

Logic: RAM (programming variables) error during self test

Possible Causes: Faulty program

Diagnosis & Solution:

1. Verify that Last Fault is FC 43: Yes, continue diagnosis; No, troubleshoot actual last fault.
2. Replace control.

SPEED SENSE FAULT – FAULT CODE 45

⚠️WARNING *Some genset service procedures present hazards that can result in severe personal injury or death. Only trained and experienced persons with knowledge of fuels, electricity, and machinery hazards should perform genset service. See Safety Precautions.*

Logic: While running quadrature frequency dropped to 0Hz for 1 continuous second

Possible Causes: Auto Gen Start (AGS), fuel supply, air fuel mixture, exhaust system, loads, Inverter/Charger, choke, demand regulator, carburetor, generator drive system, generator windings, ignition, wire connections

Diagnosis & Repair:

1. Verify that Last Fault is FC 45: Yes, continue diagnosis; No, troubleshoot actual last fault.
2. Verify whether AGS stopped genset: Yes, disable AGS or explain AGS function to customer (see PSB-666); No, continue diagnosis.
3. Verify engine rotation manually: repair engine damage as necessary.
4. Disconnect genset control P1 connector, verify P1 pins are fully inserted and inspect pin condition per PSB-676: insert, repair or replace pins as necessary.
5. Reconnect P1 connector and test run genset for fault occurrence: repair or replace pins in connector as necessary.
6. Check air filter cleanliness; replace air filter as necessary.
7. Check for blocked or damaged exhaust system: repair or replace exhaust components as necessary.
8. Measure AC current while running genset with vehicle loads: identify faulty or short cycling loads.
9. Determine battery charge rate (typical default is 80 percent): if adjustable reduce to 30 percent.
10. Measure genset load capability with shop load bank (derate for altitude and temperature as necessary).
11. **HGJAD only** – Run genset in Engine Run Only and externally excite field F1–F2 with 12 VDC or 24 VDC and measure main and quadrature winding AC output.
12. **Non EFI** – Verify genset operation and outputs with Break-Out Tool 420-0603 and Instruction Sheet R1098.
13. Measure genset frequency and droop while running.
14. Measure AC frequency while changing engine rpm to determine if frequency response matches engine rpm response: repair damaged generator drive system as necessary.
15. **All Gasoline Models**
 - A. Vapor lock may occur in high ambient temperatures: operate in ambients at less than 120°F; verify proper installation to prevent air recirculation; correct as necessary.
 - B. Measure steady DC voltage at fuel pump while genset is cranking: repair wiring as necessary.
 - C. Try to start genset on shop fuel supply: verify tank level and fuel line condition in vehicle.

16. All Gasoline Carburetor Models

- A. Verify carburetor altitude setting: readjust as necessary.
- B. Verify choke operation, setting, linkage, vacuum pull off assembly and sustain valve: readjust, repair or replace as necessary.
- C. Measure fuel pump pressure/flow: replace fuel filter or fuel pump as necessary.
- D. Inspect carburetor butterfly for binding: replace carburetor as necessary.

17. All Gasoline EFI Models

- A. Inspect throttle body for binding or damage: replace as necessary.
- B. Measure fuel pump pressure/flow: replace fuel filter, pressure regulator or fuel pump as necessary.

18. Propane Models

- A. When ambient temperatures are less than 40°F vapor-withdrawal Propane tanks should be at least half full to provide proper vaporization rate.
 - B. Propane having more than 2.5 percent Butane will not vaporize in ambients at less than 32°F; use HD-5 grade Propane.
 - C. Measure steady DC voltage at fuel solenoid while genset is running; repair wiring as necessary.
 - D. Verify clear vent hose.
 - E. Run genset on shop fuel supply; verify tank level and fuel line condition in vehicle.
 - F. Check genset fuel lines for damage: replace fuel line as required.
 - G. Measure regulator lock off pressure.
19. Check governor, actuator, linkage and spring for debris, damage and looseness: readjust and repair as necessary.
20. Verify that spark plug cables are secure on spark plugs: reconnect or replace as necessary.
21. Test Magnetos
- A. Disconnect Connector P1.
 - B. Connect positive(+) meter lead to chassis ground.
 - C. **HGJAA, D, E, F** – Measure continuity to negative lead at pin P1-4 and P1-5: replace magnetos as necessary.
 - D. **HGJAB, C** – Measure continuity to negative lead at pin P1-15 and P1-20: replace magnetos as necessary.
22. Inspect ignition kill leads in harness and at connector P1: repair or replace lead, terminal or pins as necessary.
23. Measure spark plug gap: set gap or replace spark plugs as necessary.
24. Verify ignition spark condition.
25. Inspect spark plug lead, kill lead terminal at magneto and measure magneto air gap: replace terminals, set gap or replace magnetos as necessary.
26. Measure temperature of air intake and temperature rise across genset; remove blockage or prevent air recirculation.
27. Dealers contact Distributor for technical support, Distributors contact factory for technical support.

IGNITION FAULT – FAULT CODE 47

⚠WARNING *Some genset service procedures present hazards that can result in severe personal injury or death. Only trained and experienced persons with knowledge of fuels, electricity, and machinery hazards should perform genset service. See Safety Precautions.*

Logic:

HGJAB, C – No ignition signal at P1–15 for 1 continuous second

HGJAA – No ignition signal at P1–5 for 1 continuous second

HGJAD, E, F prior to 2004 – No ignition signal at P1–5 for 1 continuous second

HGJAD, E, F after 2004 in Engine Run Only mode only – No ignition signal at P1–5 for continuous second

Possible Causes: Wire connections, windings, ignition system, generator drive system

Diagnosis & Repair:

1. Verify that Last Fault is FC 47: Yes, continue diagnosis; No, troubleshoot actual last fault.
2. Alternating FC 47 and FC 37: Magneto gap too wide: reset magneto gap, retest.
3. Test Magnetos
 - A. Disconnect Connector P1.
 - B. Connect positive(+) meter lead to chassis ground.
 - C. **HGJAA, D, E, F** – Measure continuity to negative lead at pin P1–4 and P1–5: replace magnetos as necessary.
 - D. **HGJAB, C** – Measure continuity to negative lead at pin P1–15 and P1–20: replace magnetos as necessary.
4. **HGJAD only** – Run genset in Engine Run Only and externally excite field with 12 VDC or 24 VDC and measure main and quadrature winding AC output.
5. **Non EFI only** – If the genset will not stay running measure genset frequency, quadrature winding and main winding voltages using Break-Out Tool 420–0603 and Instruction Sheet R1098.
6. Measure AC frequency while changing engine rpm to determine if frequency response matches engine rpm response: repair damaged generator drive system as necessary.
7. Measure field, quadrature and main winding resistance: clean slip rings, replace brushes, repair harness and replace rotor or stator as necessary.
8. Measure field, quadrature and main winding resistance to ground: clean slip rings, replace brushes, repair harness and replace rotor or stator as necessary.
9. Measure field, quadrature and main winding resistance to each other: clean slip rings, replace brushes, repair harness and replace rotor or stator as necessary.
10. Check brush alignment per PSB-682a.
11. Verify that spark plug cables are secure on spark plugs: reconnect or replace as necessary.
12. Inspect ignition kill leads in harness and at connector P1: repair or replace lead, terminal or pins as necessary.
13. Measure spark plug gap: set gap or replace spark plugs as necessary.
14. Verify ignition spark condition.
15. Inspect spark plug lead, kill lead terminal at magneto and measure magneto air gap: replace terminals, set gap or replace magnetos as necessary.
16. Dealers contact Distributor for technical support, Distributors contact factory for technical support.

FIELD SENSE FAULT – FAULT CODE 48

⚠WARNING *Some genset service procedures present hazards that can result in severe personal injury or death. Only trained and experienced persons with knowledge of fuels, electricity, and machinery hazards should perform genset service. See Safety Precautions.*

Logic: Controller unable to sense field voltage

Possible Causes: Faulty control

Diagnosis & Solution:

1. Verify that Last Fault is FC 48: Yes, continue diagnosis; No, troubleshoot actual last fault.
2. Replace control.

PROCESSOR FAILURE – FAULT CODE 51

⚠WARNING *Some genset service procedures present hazards that can result in severe personal injury or death. Only trained and experienced persons with knowledge of fuels, electricity, and machinery hazards should perform genset service. See Safety Precautions.*

Logic: Processor error

Possible Causes: Faulty control

Diagnosis & Solution:

1. Verify that Last Fault is FC 51: Yes, continue diagnosis; No, troubleshoot actual last fault.
2. Replace control.

FUEL INJECTOR FAULT – FAULT CODE 52

⚠WARNING *Some genset service procedures present hazards that can result in severe personal injury or death. Only trained and experienced persons with knowledge of fuels, electricity, and machinery hazards should perform genset service. See Safety Precautions.*

Logic: Open or shorted fuel injector

Possible Causes: P1–17, wire connections, fuel injector

Diagnosis & Solution:

1. Verify that Last Fault is FC 52: Yes, continue diagnosis; No, troubleshoot actual last fault.
2. Measure P1–17 open to ground on EFI set: ground lead as required for carburetor configuration.
3. Inspect connector at injectors for looseness and damage, repair or replace connector as necessary.
4. Disconnect genset control P1 connector, verify P1 pins are fully inserted and inspect pin condition per PSB–676: insert, repair or replace pins as necessary.
5. Reconnect P1 connector and test run genset for fault occurrence: repair or replace pins in connector as necessary.
6. Measure for continuity between P1–23 – INJ1 and P1–35 – INJ2: repair or replace harness as necessary.
7. Measure for continuity to ground from P1–23, P1–35, INJ1 and INJ2: repair or replace harness as necessary.
8. Replace injector.
9. Dealers contact Distributor for technical support, Distributors contact factory for technical support.

MAT SENSOR FAULT – FAULT CODE 54

⚠WARNING *Some genset service procedures present hazards that can result in severe personal injury or death. Only trained and experienced persons with knowledge of fuels, electricity, and machinery hazards should perform genset service. See Safety Precautions.*

Logic: MAT sender input greater than 300K ohms

Possible Causes: P1–17, wire connections, MAT sender

Diagnosis & Solution:

1. Verify that Last Fault is FC 54: Yes, continue diagnosis; No, troubleshoot actual last fault.
2. Measure P1–17 open to ground on EFI set: ground lead as required for carburetor configuration.
3. Inspect connector at sender for looseness and damage, repair or replace connector as necessary.
4. Disconnect genset control P1 connector, verify P1 pins are fully inserted and inspect pin condition per PSB–676: insert, repair or replace pins as necessary.
5. Reconnect P1 connector and test run genset for fault occurrence: repair or replace pins in connector as necessary.
6. Measure for continuity across harness between P1–25 – MAT(A) and P1–20 – MAT(B): repair or replace harness as necessary.
7. Measure resistance of MAT: Replace sender as necessary.
8. Dealers contact Distributor for technical support, Distributors contact factory for technical support.

MAP SENSOR FAULT – FAULT CODE 56

⚠WARNING *Some genset service procedures present hazards that can result in severe personal injury or death. Only trained and experienced persons with knowledge of fuels, electricity, and machinery hazards should perform genset service. See Safety Precautions.*

Logic: MAP sensor input less than 50kPa at start

Possible Causes: P1–17, ambient pressure/altitude, wire connections, MAP sender, wide open throttle (WOT) during start

Diagnosis & Solution:

1. Verify that Last Fault is FC 56: Yes, continue diagnosis; No, troubleshoot actual last fault.
2. Measure P1–17 open to ground on EFI set: ground lead as required for carburetor configuration.
3. Verify ambient pressure greater than 50kPa: change altitude.
4. Inspect connector at sender for looseness and damage: repair or replace connector as necessary.
5. Disconnect genset control P1 connector, verify P1 pins are fully inserted and inspect pin condition per PSB–676: insert, repair or replace pins as necessary.
6. Reconnect P1 connector and test run genset for fault occurrence: repair or replace pins in connector as necessary.
7. Measure for continuity across harness between P1–31 – MAP(A), P1–22 – MAP(B) and P1–30 – MAP(C): repair or replace harness as necessary.
8. Measure resistance on sender between MAP(A), MAP(B) and MAP(C): replace sender as necessary.
9. Measure fuel pump pressure/flow: replace fuel filter, pressure regulator or fuel pump as necessary.
10. Dealers contact Distributor for technical support, Distributors contact factory for technical support.

OVERPRIME FAULT – FAULT CODE 57

⚠WARNING *Some genset service procedures present hazards that can result in severe personal injury or death. Only trained and experienced persons with knowledge of fuels, electricity, and machinery hazards should perform genset service. See Safety Precautions.*

Logic: Genset priming: 3 consecutive minutes

Possible Causes: Wiring harness, faulty switch, AGS

Diagnosis & Repair:

1. Verify that Last Fault is FC 57: Yes, continue diagnosis; No, troubleshoot actual last fault.
2. Check for an object holding switch in stop position: remove object.
3. Disconnect genset control P1 connector, verify P1 pins are fully inserted and inspect pin condition per PSB-676: insert, repair or replace pins as necessary.
4. Reconnect P1 connector and test run genset for fault occurrence: repair or replace pins in connector as necessary.
5. Measure for continuity change across start/stop switch between neutral and stop position at switches and P1 connector: replace switches as necessary or disconnect external stop device if so equipped.
6. Dealers contact Distributor for technical support, Distributors contact factory for technical support.

STRAPE'S JAWL - PART 11 CODE 11

Additional information regarding the project is available on the project website. The project is a multi-phase development and is currently in the planning stage. The project is located in the heart of the city and is expected to be completed by the end of the year. The project is a major development and is expected to bring significant benefits to the community. The project is a multi-phase development and is currently in the planning stage. The project is located in the heart of the city and is expected to be completed by the end of the year. The project is a major development and is expected to bring significant benefits to the community.

This side is intentionally blank

12. Service Checklist

GENERAL

Before reinstalling the genset, repair any damage to and seal all holes in the vapor-tight, fire-resistive barrier between the genset and coach interior.

After servicing or reinstalling a genset conduct the following checks and tests to determine that the genset will operate safely and perform as required.

MOUNTING

Check for proper mounting and tighten all fasteners securely. Make sure the air inlet and outlet openings in the bottom of the genset are not restricted in any way and that there is access for changing the oil filter and draining oil.

WIRING

⚠WARNING *Batteries give off explosive gases that can cause severe personal injury — Do not smoke — Keep flames, sparks, pilot lights, switches, arc-producing equipment and all other ignition sources away.*

Make sure all AC output, control, ground and battery connections are tight and properly installed. Check wiring for cuts, cracks and abrasions and make sure it does not rub against anything that could cause damage.

EXHAUST SYSTEM

Make certain that the exhaust tail pipe terminates beyond the perimeter of the vehicle and not near vents or openable windows or doors. Test the on-board CO alarm(s). See the Installation Manual for important considerations concerning the installation of an exhaust system.

When the genset is up and running, look and listen for leaks at all connections, welds, gaskets, and

joints along the whole length of the exhaust system. Repair all leaks before putting the genset in service.

FUEL SYSTEM

Check flexible sections for cuts, cracks and abrasions and make sure they do not rub against anything that could cause damage. On models equipped with fuel injection, make sure proper connections have been made for a fuel return line all the way back to the fuel tank.

⚠WARNING *Gasoline is flammable and explosive and can cause severe personal injury or death — Stop priming immediately if you smell gasoline or see fuel leaking and clean up spilled fuel and ventilate area before starting the genset or vehicle — Do not smoke — Keep flames, sparks, pilot lights, switches, arc-producing equipment and all other ignition sources away — Keep an ABC fire extinguisher handy.*

Gasoline Models: Recheck all fuel connections for tightness and then prime the fuel system by holding the control switch at STOP/PRIME while checking for fuel line leaks. Fix all leaks before starting the genset.

⚠WARNING *LPG is flammable and explosive and can cause asphyxiation. NFPA 58, Section 1.6 requires all persons handling LPG to be trained in proper handling and operating procedures.*

⚠WARNING *LPG “sinks” and can accumulate in explosive concentrations. Before connecting or disconnecting the LPG fuel line, close the fuel shutoff valve(s) at the LPG container(s) and move the vehicle outside and away from pits, basements, and other below-grade spaces where LPG could accumulate.*

LPG Models: Recheck all fuel connections for tightness. Make sure proper connections have been made at the LPG container(s). A genset equipped for Low-Pressure LPG (vapor withdrawal) must not

be connected for high-pressure (liquid withdrawal), and vice versa. For Low-Pressure LPG, check and adjust LPG supply pressure to obtain 9–13 inches (228–330 mm) WC (water column) at all loads. Fix all leaks before starting the genset.

STARTUP

⚠ WARNING ***EXHAUST GAS IS DEADLY! Do not operate the genset when the vehicle is indoors or where exhaust can accumulate.***

Read the Operator's Manual and perform the maintenance and pre-start checks instructed. *Check the oil level and fill as necessary.*

⚠ CAUTION ***Frequency-sensitive equipment such as VCRs, televisions, computers, etc. can be damaged by power line frequency variations. Some solid-state devices are powered whenever connected to an AC outlet even if the device is not in actual operation. For this reason, disconnect all devices that are voltage- or frequency-sensitive before attempting any governor adjustments. If disconnecting the devices is not possible, open the circuit breaker(s) at the distribution panel or at the genset.***

If the genset is equipped with a mechanical governor and frequency adjustments have yet to be made, make sure all frequency sensitive equipment has been disconnected. Start the genset and adjust the governor as necessary (see Section 8. *Fuel System*).

Operate the genset following all the instructions and safety precautions in the Operator's Manual. Check for fuel and exhaust leaks and unusual noises while the genset is running under full and intermediate loads. Do not place the genset in service until all fuel and exhaust leaks have been fixed and operation is satisfactory.

OUTPUT CHECK

Apply a full load to make sure the genset can produce its full rated output. Use a load test panel to apply a progressively greater load until full load is reached.

CONTROL

Stop and start the genset several times at the genset control and remote control (if so equipped) to verify that it functions properly.

13. Specifications

	GASOLINE MODELS					
	7.0 HGJAA	7.0 HGJAB	7.0 HGJAC	5.5 HGJAA	5.5 HGJAB	5.5 HGJAC
GENERATOR: 2-Pole Revolving Field, 2-Bearing, Self-Excited, 1-Phase, Vertical Shaft, Capped Digital Voltage Regulation						
Power	7000 watts			5500 watts		
Frequency	60 Hertz			60 Hertz		
Voltage	120 volts			120 volts		
Current	58.3 amp			45.8 amp		
Speed	3600 rpm			3600 rpm		
FUEL CONSUMPTION:						
No load	0.43 gph (1.6 l/h)	0.43 gph (1.6 l/h)	0.43 gph (1.6 l/h)	0.34 gph (1.3 l/h)	0.35 gph (1.3 l/h)	0.35 gph (1.3 l/h)
Half load	0.70 gph (2.7 l/h)	0.73 gph (2.8 l/h)	0.73 gph (2.8 l/h)	0.58 gph (2.2 l/h)	0.60 gph (2.3 l/h)	0.60 gph (2.3 l/h)
Full load	1.13 gph (4.3 l/h)	1.22 gph (4.6 l/h)	1.22 gph (4.6 l/h)	0.89 gph (3.4 l/h)	0.95 gph (3.6 l/h)	0.95 gph (3.6 l/h)
ENGINE: Air-Cooled, 4-Cycle Spark-Ignited, OHV, 90° V Twin Cyl, Vertical Shaft						
Fueling Method	SFI ¹	Carburetor	Carburetor	SFI ¹	Carburetor	Carburetor
Governor	Digital	Mechanical	Mechanical	Digital	Mechanical	Mechanical
Speed	2880 rpm			2400 rpm		
Bore	3.15 in (80 mm)			3.15 in (80 mm)		
Stroke	2.56 in (65 mm)			2.56 in (65 mm)		
Displacement	39.8 in ³ (653 cc)			39.8 in ³ (653 cc)		
Comp. Ratio	8.0 : 1			8.0 : 1		
Cyl. Comp. Test	153-188 psi			153-188 psi		
Oil Capacity	2.0 quart (1.8 l)			2.0 quart (1.8 l)		
Valve Lash (Cold)	0.004 in (0.10 mm), Intake & Exhaust			0.004 in (0.10 mm), Intake & Exhaust		
Spark Plug	18–25 lbs-ft (23–32 N-m)			18–25 lbs-ft (23–32 N-m)		
Ignition Timing	20° BTDC, non-adjustable magneto			20° BTDC, non-adjustable magneto		
Magneto Air Gap	0.012 in (0.3 mm)			0.012 in (0.3 mm)		
Spark Plug Gap	0.025 in (0.6-0.7 mm)			0.025 in (0.6-0.7 mm)		
DC SYSTEM:						
Battery Voltage	12 volts			12 volts		
Min. Battery CCA	450 @ 0° F (-18° C)			450 @ 0° F (-18° C)		
INSTALLATION:						
Exhaust O. D.	1-1/4 in			1-1/4 in		
Max. Exhaust Back Pressure	–	–	35 in (889 mm) WC	–	–	35 in (889 mm) WC
Fuel Supply Connection	5/16 in. SAE J1231 Type 1	1/4 in. SAE J1231 Type 1	1/4 in. SAE J1231 Type 1	5/16 in. SAE J1231 Type 1	1/4 in. SAE J1231 Type 1	1/4 in. SAE J1231 Type 1
Fuel Return Connection	1/4 in. SAE J1231 Type 1	–	–	1/4 in. SAE J1231 Type 1	–	–
Noise dB(A) ²	66	67	75	66	67	75
Weight	290 lb (132 Kg)	290 lb (132 Kg)	239 lb (107 Kg)	279 lb (127 Kg)	279 lb (127 Kg)	228 lb (104 Kg)
Compartment (H x D x W) ³	HGJAA/HGJAB: 17.2 in x 23.2 in x 34.6 in (438 mm x 589 mm x 879 mm) HGJAC: 16.5 in x 22.8 in x 27.9 in (420 mm x 579 mm x 709 mm)					
1. Sequential Multiport Fuel Injection 2. Measurements @ 10 ft (3 m) in a typical RV installation, under an 4 kW load. 3. With 1/2 in. clearances. See the Installation Manual for additional considerations when sizing the genset compartment.						

	LPG MODELS					
	6.5 HGJAA	6.5 HGJAB	6.5 HGJAC	5.5 HGJAA	5.5 HGJAB	5.5 HGJAC
GENERATOR: 2-Pole Revolving Field, 2-Bearing, Self-Excited, 1-Phase, Vertical Shaft, Capped Digital Voltage Regulation						
Power	6500 watts			5500 watts		
Frequency	60 Hertz			60 Hertz		
Voltage	120 volts			120 volts		
Current	54.2 amp			45.8 amp		
Speed	3600 rpm			3600 rpm		
FUEL CONSUMPTION:						
No load	2.2 lbs/h (1.0 kg/h)	2.2 lbs/h (1.0 kg/h)	2.2 lbs/h (1.0 kg/h)	1.8 lbs/h (0.8 kg/h)	1.8 lbs/h (0.8 kg/h)	1.8 lbs/h (0.8 kg/h)
Half load	3.9 lbs/h (1.8 kg/h)	3.9 lbs/h (1.8 kg/h)	3.9 lbs/h (1.8 kg/h)	3.3 lbs/h (1.5 kg/h)	3.3 lbs/h (1.5 kg/h)	3.3 lbs/h (1.5 kg/h)
Full load	5.3 lbs/h (2.4 kg/h)	5.3 lbs/h (2.4 kg/h)	5.3 lbs/h (2.4 kg/h)	4.6 lbs/h (2.1 kg/h)	4.6 lbs/h (2.1 kg/h)	4.6 lbs/h (2.1 kg/h)
ENGINE: Air-Cooled, 4-Cycle Spark-Ignited, OHV, 90° V Twin Cyl, Vertical Shaft						
Fueling Method	Air/Fuel Mixer			Air/Fuel Mixer		
Governor	Mechanical			Mechanical		
Speed	2880 rpm			2400 rpm		
Bore	3.15 in (80 mm)			3.15 in (80 mm)		
Stroke	2.56 in (65 mm)			2.56 in (65 mm)		
Displacement	39.8 in ³ (653 cc)			39.8 in ³ (653 cc)		
Comp. Ratio	8.0 : 1			8.0 : 1		
Cyl. Comp. Test	153-188 psi			153-188 psi		
Oil Capacity	2.0 quart (1.8 l)			2.0 quart (1.8 l)		
Valve Lash (Cold)	0.004 in (0.10 mm), Intake & Exhaust			0.004 in (0.10 mm), Intake & Exhaust		
Spark Plug	18–25 lbs-ft (23–32 N-m)			18–25 lbs-ft (23–32 N-m)		
Ignition Timing	20° BTDC, non-adjustable magneto			20° BTDC, non-adjustable magneto		
Magneto Air Gap	0.012 in (0.3 mm)			0.012 in (0.3 mm)		
Spark Plug Gap	0.025 in (0.6-0.7 mm)			0.025 in (0.6-0.7 mm)		
DC SYSTEM:						
Battery Voltage	12 volts			12 volts		
Min. Battery CCA	450 @ 0° F (-18° C)			450 @ 0° F (-18° C)		
INSTALLATION:						
Exhaust O. D.	1-1/4 in			1-1/4 in		
Max. Exhaust Back Pressure	–	–	35 in (889 mm) WC	–	–	35 in (889 mm) WC
LPG Vapor: Connection Pressure	3/8–18 NPTF 9-13 in (228-330 mm) WC			3/8–18 NPTF 9-13 in (228-330 mm) WC		
LPG Liquid: Connection Pressure	1/4–18 NPTF Tank Pressure			1/4–18 NPTF Tank Pressure		
Noise dB(A) ¹	66	67	75	66	67	75
Weight	290 lb (132 Kg)	290 lb (132 Kg)	239 lb (107 Kg)	279 lb (127 Kg)	279 lb (127 Kg)	228 lb (104 Kg)
Compartment (H x D x W) ²	HGJAA/HGJAB: 17.2 in x 23.2 in x 34.6 in (438 mm x 589 mm x 879 mm) HGJAC: 16.5 in x 22.8 in x 27.9 in (420 mm x 579 mm x 709 mm)					
1. Measurements @ 10 ft (3 m) in a typical RV installation, under an 4 kW load. 2. With 1/2 in. clearances. See the Installation Manual for additional considerations when sizing the genset compartment.						

	GASOLINE MODELS					
	7.0 HGJAD	7.0 HGJAE	7.0 HGJAF	5.5 HGJAD	5.5 HGJAE	5.5 HGJAF
GENERATOR: 2-Pole Revolving Field, 2-Bearing, Self-Excited, 1-Phase, Vertical Shaft, Capped Digital Voltage Regulation						
Power (1.0 PF) ¹	7000 watts			5500 watts		
Frequency	60 Hertz			60 Hertz		
1-Ph, 4-Wire V/A	120 / 240 Volts, 29.2 Amps			120 / 240 Volts, 22.9 Amps		
1-Ph, 2-Wire V/A	120 Volts, 58.3 Amps			120 Volts, 45.8 Amps		
3-Ph V/A	120 / 240 Volts, 16.8 Amps			120 / 240 Volts, 12 Amps		
Speed	3600 rpm			3600 rpm		
FUEL CONSUMPTION:						
No load	0.43 gph (1.6 l/h)	0.43 gph (1.6 l/h)	0.43 gph (1.6 l/h)	0.34 gph (1.3 l/h)	0.35 gph (1.3 l/h)	0.35 gph (1.3 l/h)
Half load	0.70 gph (2.7 l/h)	0.73 gph (2.8 l/h)	0.73 gph (2.8 l/h)	0.58 gph (2.2 l/h)	0.60 gph (2.3 l/h)	0.60 gph (2.3 l/h)
Full load	1.13 gph (4.3 l/h)	1.22 gph (4.6 l/h)	1.22 gph (4.6 l/h)	0.89 gph (3.4 l/h)	0.95 gph (3.6 l/h)	0.95 gph (3.6 l/h)
ENGINE: Air-Cooled, 4-Cycle Spark-Ignited, OHV, 90° V Twin Cyl, Vertical Shaft						
Fueling Method	SFI ²	Carburetor	Carburetor	SFI ²	Carburetor	Carburetor
Governor	Digital	Mechanical	Mechanical	Digital	Mechanical	Mechanical
Speed	2880 rpm			2400 rpm		
Bore	3.15 in (80 mm)			3.15 in (80 mm)		
Stroke	2.56 in (65 mm)			2.56 in (65 mm)		
Displacement	39.8 in ³ (653 cc)			39.8 in ³ (653 cc)		
Comp. Ratio	8.0 : 1			8.0 : 1		
Cyl. Comp. Test	153-188 psii			153-188 psii		
Oil Capacity	2.0 quart (1.8 l)			2.0 quart (1.8 l)		
Valve Lash (Cold)	0.004 in (0.10 mm), Intake & Exhaust			0.004 in (0.10 mm), Intake & Exhaust		
Spark Plug	18–25 lbs-ft (23–32 N-m)			18–25 lbs-ft (23–32 N-m)		
Ignition Timing	20° BTDC, non-adjustable magneto			20° BTDC, non-adjustable magneto		
Magneto Air Gap	0.012 in (0.3 mm)			0.012 in (0.3 mm)		
Spark Plug Gap	0.025 in (6-7 mm)			0.025 in (6-7 mm)		
HYDRAULIC PUMP:	Fixed-displacement gear pump—1.8 gpm @ 2500 psi			Fixed-displacement gear pump—1.6 gpm @ 2500 psi		
DC SYSTEM:						
Battery Voltage	12 volts			12 volts		
Battery Charging	10 amps regulated			10 amps regulated		
Min. Battery CCA	450 @ 0° F (–18° C)			450 @ 0° F (–18° C)		
INSTALLATION:						
Exhaust O. D.	1-1/4 in			1-1/4 in		
Max. Exhaust Back Pressure	–	–	35 in (889 mm) WC	–	–	35 in (889 mm) WC
Fuel Supply Connection	5/16 in. SAE J1231 Type 1	1/4 in. SAE J1231 Type 1	1/4 in. SAE J1231 Type 1	5/16 in. SAE J1231 Type 1	1/4 in. SAE J1231 Type 1	1/4 in. SAE J1231 Type 1
Fuel Return Connection	5/16 in. SAE J1231 Type 1	–	–	5/16 in. SAE J1231 Type 1	–	–
Hydraulic Fluid	Transmission or Petroleum-Based Hydraulic Fluid—Operating Viscosity: 80-1000 SSU—Maximum Start-Up Viscosity: 4000 SSU			Transmission or Petroleum-Based Hydraulic Fluid—Operating Viscosity: 80-1000 SSU—Maximum Start-Up Viscosity: 4000 SSU		
Hydraulic Pump Inlet Conditions	Not to exceed 5 in Hg Vacuum or 20 psi Pressure			Not to exceed 5 in Hg Vacuum or 20 psi Pressure		
Hydraulic Pump Connections Outlet Inlet	3/4-16 UNF-2B SAE 7/8-14 UNF-2B SAE			3/4-16 UNF-2B SAE 7/8-14 UNF-2B SAE		
Noise dB(A) ³	66	67	75	66	67	75
Weight	290 lb (132 Kg)	290 lb (132 Kg)	239 lb (107 Kg)	279 lb (127 Kg)	279 lb (127 Kg)	228 lb (104 Kg)
Compartment (H x D x W) ⁴	HGJAD/HGJAE: 17.2 in x 23.2 in x 34.6 in (438 mm x 589 mm x 879 mm) HGJAF: 16.5 in x 22.8 in x 27.9 in (420 mm x 579 mm x 709 mm)					
1. A genset with a hydraulic pump is rated with the pump idle. 2. Sequential Multiport Fuel Injection 3. Measurements @ 10 ft (3 m) in a typical installation, under an 4 kW load. 4. With 1/2 in. clearances. See the Installation Manual for additional considerations when sizing the genset compartment.						

	LPG MODELS			
	6.5 HGJAE	6.5 HGJAF	5.5 HGJAE	5.5 HGJAF
GENERATOR: 2-Pole Revolving Field, 2-Bearing, Self-Excited, 1-Phase, Vertical Shaft, Capped Digital Voltage Regulation				
Power (1.0 PF) ¹	6500 watts		5500 watts	
Frequency	60 Hertz		60 Hertz	
1-Ph, 4-Wire V/A	120 / 240 Volts, 27 Amps		120 / 240 Volts, 22.9 Amps	
Speed	3600 rpm		3600 rpm	
FUEL CONSUMPTION:				
No load	2.2 lbs/h (1.0 kg/h)	2.2 lbs/h (1.0 kg/h)	1.8 lbs/h (0.8 kg/h)	1.8 lbs/h (0.8 kg/h)
Half load	3.9 lbs/h (1.8 kg/h)	3.9 lbs/h (1.8 kg/h)	3.3 lbs/h (1.5 kg/h)	3.3 lbs/h (1.5 kg/h)
Full load	5.3 lbs/h (2.4 kg/h)	5.3 lbs/h (2.4 kg/h)	4.6 lbs/h (2.1 kg/h)	4.6 lbs/h (2.1 kg/h)
ENGINE: Air-Cooled, 4-Cycle Spark-Ignited, OHV, 90° V Twin Cyl, Vertical Shaft				
Fueling Method	Air/Fuel Mixer		Air/Fuel Mixer	
Governor	Mechanical		Mechanical	
Speed	2880 rpm		2400 rpm	
Bore	3.15 in (80 mm)		3.15 in (80 mm)	
Stroke	2.56 in (65 mm)		2.56 in (65 mm)	
Displacement	39.8 in ³ (653 cc)		39.8 in ³ (653 cc)	
Comp. Ratio	8.0 : 1		8.0 : 1	
Cyl. Comp. Test	153-188 psi		153-188 psi	
Oil Capacity	2.0 quart (1.8 l)		2.0 quart (1.8 l)	
Valve Lash (Cold)	0.004 in (0.10 mm), Intake & Exhaust		0.004 in (0.10 mm), Intake & Exhaust	
Spark Plug	18–25 lbs-ft (23–32 N-m)		18–25 lbs-ft (23–32 N-m)	
Ignition Timing	20° BTDC, non-adjustable magneto		20° BTDC, non-adjustable magneto	
Magneto Air Gap	0.012 in (0.3 mm)		0.012 in (0.3 mm)	
Spark Plug Gap	0.025 in (6-7 mm)		0.025 in (6-7 mm)	
HYDRAULIC PUMP:	Fixed-displacement gear pump—1.8 gpm @ 2500 psi		Fixed-displacement gear pump—1.6 gpm @ 2500 psi	
DC SYSTEM:				
Battery Voltage	12 volts		12 volts	
Battery Charging	10 amps regulated		10 amps regulated	
Min. Battery CCA	450 @ 0° F (-18° C)		450 @ 0° F (-18° C)	
INSTALLATION:				
Exhaust O. D.	1-1/4 in		1-1/4 in	
Max. Exhaust Back Pressure	–	35 in (889 mm) WC	–	35 in (889 mm) WC
LPG Vapor: Connection Pressure	3/8–18 NPTF 9-13 in (228-330 mm) WC		3/8–18 NPTF 9-13 in (228-330 mm) WC	
LPG Liquid: Connection Pressure	1/4–18 NPTF Tank Pressure		1/4–18 NPTF Tank Pressure	
Hydraulic Fluid	Transmission or Petroleum-Based Hydraulic Fluid—Operating Viscosity: 80-1000 SSU—Maximum Start-Up Viscosity: 4000 SSU		Transmission or Petroleum-Based Hydraulic Fluid—Operating Viscosity: 80-1000 SSU—Maximum Start-Up Viscosity: 4000 SSU	
Hydraulic Pump Inlet Conditions	Not to exceed 5 in Hg Vacuum or 20 psi Pressure		Not to exceed 5 in Hg Vacuum or 20 psi Pressure	
Hydraulic Pump Connections Outlet Inlet	3/4-16 UNF-2B SAE 7/8-14 UNF-2B SAE		3/4-16 UNF-2B SAE 7/8-14 UNF-2B SAE	
Noise dB(A) ²	67	75	67	75
Weight	290 lb (132 Kg)	239 lb (107 Kg)	279 lb (127 Kg)	228 lb (104 Kg)
Compartment (H x D x W) ³	HGJAD/HGJAE: 17.2 in x 23.2 in x 34.6 in (438 mm x 589 mm x 879 mm) HGJAF: 16.5 in x 22.8 in x 27.9 in (420 mm x 579 mm x 709 mm)			
1. A genset with an hydraulic pump is rated with the pump idle. 2. Measurements @ 10 ft (3 m) in a typical installation, under an 4 kW load. 3. With 1/2 in. clearances. See the Installation Manual for additional considerations when sizing the genset compartment.				

14. Torque Specifications

	lb-ft*	N-m *
Spark Plugs	10 (New), 18 (Reused)	13 (New), 24 (Reused)
Genset Mounting Screws	35	48
Generator Through Bolts	8	11
Belt Tensioner Center Bolt	20	26
Generator Pulley Center Bolt	45	61
Fan Screws	8	11
Flywheel to Pulley Coupling Nuts	5	6
Flywheel Center Bolt	60	81
Magneto Mounting Screws	5	7
Exhaust Manifold Flange Nuts	20	26
Fan Shroud Screws	8	11
Muffler Flange Nuts	10	13
Intake Manifold Bolts	19	26
Throttle Body / Carburetor / Mixer Mounting Nuts	4.5	6
Fuel Rail Mounting Screws (EFI)	75 lb-inch	8.4
Throttle Body Stator Screws (EFI)	18 lb-inch	2
LPG Inlet Filter	25	34
Governor Arm Shaft Nut (Counterclockwise)	8	11
Generator / Engine Assembly Fail Safe Bolts	38	51
Engine Mounting Screws	20	26
Cylinder Shroud Screws	8	11
Starter Motor Mounting Screws	20	26
Starter Terminal Nut	6.5	8
Valve Lash Adjustment Lock Nuts	6.5	8
Valve Cover Screws	5.5	8
Cylinder Head Bolts (Three equal increments)	24.6-30.4	33.3-41.2
Engine Breather Valve Cover Screws	3	4
Connecting Rod Cap Bolts	16.3-19.9	22.1-27.0
Crankcase Cover Screws	16.2-16.9	22-23
Hydraulic Pump Mounting Flange Bolts	20	26

* – Use engine oil as a lubricant for all threads except when otherwise specified.

Time (min)	Angular Velocity (rad/s)	Torque (N·m)	Power (W)
0	0	0	0
10	10	10	100
20	20	20	400
30	30	30	900
40	40	40	1600
50	50	50	2500
60	60	60	3600
70	70	70	4900
80	80	80	6400
90	90	90	8100
100	100	100	10000

This side is intentionally blank



Cummins Power Generation
1400 73rd Avenue N.E.
Minneapolis, MN 55432
763-574-5000
Fax: 763-528-7229

Cummins and Onan are registered trademarks of Cummins Inc.