

## Section 4

# Driveline/Axle

<b>Propeller Shaft</b> .....	4-3	Rear Axle Disassembled Views (Drum Brakes) .....	4-25
<b>Specifications</b> .....	4-3	<b>Diagnostic Information and Procedures</b> .....	4-26
Fastener Tightening Specifications .....	4-3	Noise Diagnosis (Axle) .....	4-26
Propeller Shaft Runout Specifications .....	4-3	Noise Diagnosis (Wheel Bearing) .....	4-28
Lubrication .....	4-4	<b>Repair Instructions</b> .....	4-33
<b>Diagnostic Information and Procedures</b> .....	4-5	Axle Shaft Replacement (All Models) .....	4-33
Leak at Front Slip Yoke .....	4-5	Oil Seal and/or Bearing Replacement (Disc) .....	4-34
Roughness or Vibration (Above 56km/h ) .....	4-5	Oil Seal and/or Bearing Replacement (Drum) .....	4-36
Roughness or Vibration (General Diagnosis) .....	4-5	Wheel Stud Replacement .....	4-38
Ping, Snap, or Click Noise .....	4-7	Pinion Oil Seal Replacement (10 1/2 Ring Gear) .....	4-39
Knock or Clunk Noise .....	4-7	Pinion Oil Seal Replacement (11 Inch Ring Gear ) .....	4-41
Scraping Noise .....	4-7	Vent Hose Replacement .....	4-42
Squeak Noise .....	4-7	Inspection Before Disassembly .....	4-43
Shudder on Acceleration at Low Speed .....	4-7	Drive Axle Disassemble .....	4-43
<b>Repair Instructions</b> .....	4-8	Axle Housing Inspection .....	4-48
Propeller Shaft Replacement (One-Piece) .....	4-8	Differential Inspection .....	4-48
Two-Piece Propeller Shaft Replacement .....	4-9	Pinion and Ring Gear Inspection .....	4-48
Three-Piece Propeller Shaft Replacement .....	4-12	Bearings Inspection .....	4-48
Center Bearing Replacement .....	4-16	Shims Inspection .....	4-48
Yoke Replacement (Manual Transmission) .....	4-17	Pinion Depth Adjustment .....	4-49
Yoke Replacement (With Mounted Park Brake) .....	4-18	Differential Case Assembly .....	4-51
Yoke Replacement (Automatic Transmission ) .....	4-19	Determining Total Shim Pack Size .....	4-52
Universal Joints Replacement .....	4-20	Pinion Installation .....	4-53
<b>Description and Operation</b> .....	4-21	Differential to Axle Housing Assemble .....	4-55
Propeller Shaft Description .....	4-21	Backlash Adjustment .....	4-57
Propeller Shaft Phasing Description .....	4-21	Gear Tooth Contact Pattern Check .....	4-57
Universal Joint Description .....	4-22	Drive Axle Final Assembly .....	4-60
Center Bearing Description .....	4-22	Axle Replacement (11 in. Ring Gear ) .....	4-60
<b>Rear Drive Axle</b> .....	4-23	Axle Replacement (10 1/2 in. Ring Gear ) .....	4-61
<b>Specifications</b> .....	4-23	Pinion Flange Replacement (10 1/2 in. Ring Gear ) .....	4-63
Fastener Tightening Specifications (American Axle) .....	4-23	Pinion Flange Replacement (11 in. Ring Gear ) .....	4-65
Fastener Tightening Specifications (Dana) .....	4-23	Hub and Drum Assembly Replacement (All Models) .....	4-67
Rear Axle Specifications .....	4-23	Hub and Rotor Assembly Replacement .....	4-69
Lubrication Specifications .....	4-23	Bearing Cup Replacement (Drum) .....	4-70
<b>Component Locator</b> .....	4-24	Bearing Cup Replacement (Disc) .....	4-72
Rear Axle Disassembled Views (Disc Brakes) .....	4-24	Wheel Bearing Adjustment (Disc Brakes) .....	4-74
		Wheel Bearing Adjustment (Drum Brakes) .....	4-76
		<b>Description and Operation</b> .....	4-78
		Rear Axle Description .....	4-78
		<b>Special Tools and Equipment</b> .....	4-79

# Propeller Shaft

## Specifications

### Fastener Tightening Specifications

Application	Specification	
	Metric	English
Center Bearing Support Bolts/Nuts to Frame Hanger	53 N·m	39 lb ft
Yoke to Output Shaft Bolts	110 N·m	81 lb ft
Two or Three Piece Propeller Shaft (Front Shaft)		
Propeller Shaft to Transmission Yoke Bolts	20 N·m	15 lb ft
Propeller Shaft to Parking Brake Drum Yoke Bolts	28 N·m	21 lb ft
Two or Three Piece propeller Shaft (Rear Shaft)		
Propeller Shaft to Rear Axle (with Transmission Mounted Parking Brake Drum)	44 N·m	33 lb ft
Propeller Shaft to Rear Axle (without Transmission Mounted Parking Brake Drum)	20 N·m	15 lb ft
Three Piece Propeller Shaft Intermediate Shaft		
Propeller Shaft to Front Propeller Shaft Yoke	44 N·m	33 lb ft

### Propeller Shaft Runout Specifications

Propeller Shaft	Front Check	Center Check	Rear Check
One Piece	0.04 in (1.02 mm)	0.05 in (1.28 mm)	0.055 in (1.40 mm)
Two Piece Front	0.02 in (0.51 mm)	—	*0.008 in (0.20 mm)
Two Piece Rear	**0.03 in (0.77 mm)	0.03 in (0.77 mm)	0.035 in (0.89 mm)
Three Piece/Front/Center/Rear	0.015 in (0.38 mm)	0.01 in (0.25 mm)	0.015 in (0.38 mm)
• Measured at tapered hole in the end of the splined shaft after removing the rear propeller shaft. **Measured with the rear shaft connected to the front shaft. The front shaft must be within runout specifications.			
—			

## Lubrication

### Universal Joints

Journals of universal joints are drilled and provided with lubrication fittings through which lubricant travels to all four oil reservoirs, through a small hole inside of each reservoir, direct to the needle bearings. Seals protect the bearings against lubricant leakage, dirt, and debris.

1. Lubricate the universal joints with chassis lubricant. Refer to *Fluid and Lubricant Recommendations Maintenance and Lubrication in General Information*.

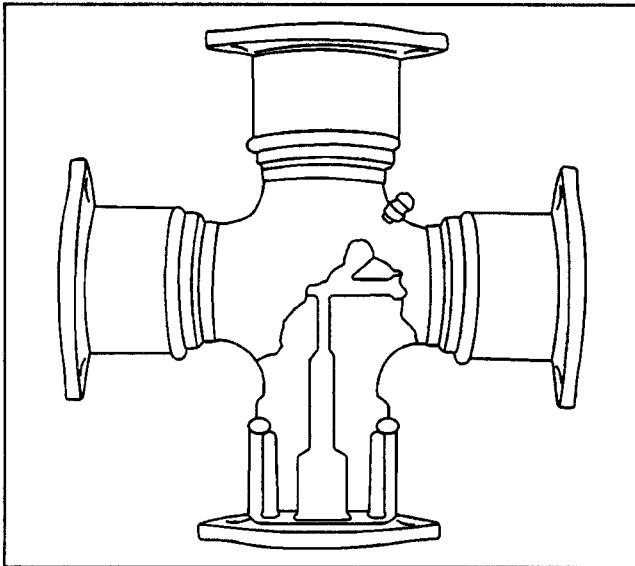

2. When greasing the joint, a flow of grease at all four trunnion seals must be visible in order to ensure lubrication of the joint.
3. If grease does not appear at all four trunnion seals, rotate the universal joint trunnion in all four directions while applying lubricant under pressure in order to relieve any airlock inside the joint. Air lock prevents the lubricant from reaching the bearing area.

**Notice:** Refer to *Fastener Notice* in Cautions and Notices.

4. If necessary, bend the lock strap out of the way and loosen the cap screws and cap enough in order to allow a flow of grease.

### Tighten

Tighten the hex head bolts to specifications. Refer to *Fastener Tightening Specifications*.

### Sliding Spline Sections (Slip Joints)

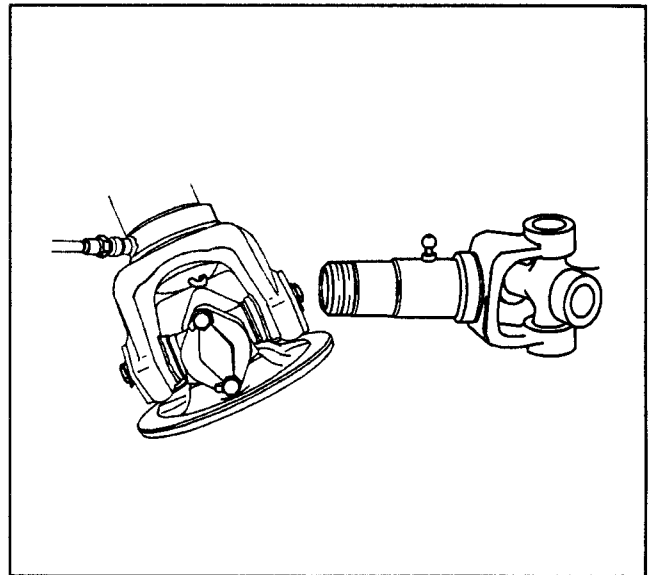

Splines of the slip joint are lubricated through a lubrication fitting installed in the slip yoke. Apply grease gun pressure to the lubrication fitting until lubrication appears at the relief hole. Refer to *Maintenance Schedule Maintenance and Lubrication in General Information* for specified times to lubricate slip yoke splines.

### Center Bearings

The center bearing is permanently lubricated. Do not add or change grease in the bearing. When installing a new center bearing, fill the entire cavity with chassis grease. The quantity should be sufficient to fill the cavity to the extreme edge of the slinger surrounding the bearing. Filling the cavity to the extreme edge shields the bearing from water and contaminants.

## Diagnostic Information and Procedures

### Leak at Front Slip Yoke

Problem	Action
DEFINITION: An occasional drop of lubricant leaking from the splined yoke is normal and requires no attention.	
The slip yoke barrel is burred, nicked, corroded, or worn.	<ul style="list-style-type: none"> <li>• Replace the seal.</li> <li>• Smooth minor burrs by careful use of crocus cloth or fine stone honing.</li> <li>• Replace a badly burred yoke. Refer to <i>Yoke Replacement (Automatic Transmission)</i> or <i>Yoke Replacement (Manual Transmission)</i> or <i>Yoke Replacement (With Mounted Park Brake)</i>.</li> </ul>
A defective transmission rear oil seal	Replace the transmission rear oil seal and replenish the transmission oil.

### Roughness or Vibration (Above 56km/h )

Problem	Action
DEFINITION: One hears or feels a roughness when driving the vehicle above 56 km/h (35 mph).	
The tires are unbalanced or worn.	Balance or replace the tires. Refer to <i>Balancing Tires and Wheels</i> in General Information or <i>Tire Mounting and Dismounting</i> .

### Roughness or Vibration (General Diagnosis)

Step	Action	Value(s)	Yes	No
1	Inspect the center bearing. Is the bearing worn?	—	Go to <i>Step 2</i>	Go to <i>Step 3</i>
2	Replace the center bearing. <i>Center Bearing Replacement</i> . Is roughness or vibration still evident?	—	Go to <i>Step 3</i>	System OK
3	Inspect the hanger. Is the hanger worn?	—	Go to <i>Step 4</i>	Go to <i>Step 5</i>
4	Replace the hanger. Is roughness or vibration still evident?	—	Go to <i>Step 5</i>	System OK
5	Inspect the universal joints. Do the universal joints require lubrication?	—	Go to <i>Step 6</i>	Go to <i>Step 7</i>
6	Lubricate the universal joints. Refer to <i>Fluid and Lubricant Recommendations</i> in Maintenance and Lubrication. Is roughness or vibration still evident?	—	Go to <i>Step 7</i>	System OK
7	Inspect the universal joints. Are the universal joints worn?	—	Go to <i>Step 8</i>	Go to <i>Step 9</i>
8	Replace the universal joints. Refer to <i>Universal Joints Replacement</i> . Is roughness or vibration still evident?	—	Go to <i>Step 9</i>	System OK
9	Inspect the flange bolts. Are the bolts loose?	—	Go to <i>Step 10</i>	Go to <i>Step 11</i>
10	Tighten the flange bolts to specification. Refer to <i>Fastener Tightening Specifications</i> . Is roughness or vibration still evident?	—	Go to <i>Step 11</i>	System OK
11	Inspect the tires. Refer to <i>Tire and Wheel Inspection</i> in Vibration Diagnosis and Correction. Are the tires worn or out of balance?	—	Go to <i>Step 12</i>	Go to <i>Step 13</i>
12	Balance or replace the tires as necessary. Refer to <i>Balancing Tires and Wheels</i> in Vibration Diagnosis and Correction or <i>Tire Mounting and Dismounting</i> in Wheels and Tires. Is roughness or vibration still evident?	—	Go to <i>Step 13</i>	System OK

## Roughness or Vibration (General Diagnosis) (cont'd)

Step	Action	Value(s)	Yes	No
13	Inspect the companion flange. Are there burrs or gouges on the companion flange?	—	Go to Step 14	Go to Step 15
14	1. Inspect the snap ring locating surfaces on the flange yoke. 2. Rework or replace the companion flange. Is roughness or vibration still evident?	—	Go to Step 15	System OK
15	Inspect the propeller shaft. Refer to <i>Diagnosing First-Order Driveline Vibration</i> in Vibration Diagnosis and Correction. Is the propeller shaft unbalanced?	—	Go to Step 16	Go to Step 17
16	1. Inspect the propeller shaft for a missing balance weight. 2. Remove the propeller shaft. 3. Install the propeller shaft to the companion flange 180° from the original position. Is roughness or vibration still evident?	—	Go to Step 17	System OK
17	Inspect the parking brake drum. Refer to <i>Brake Drum Inspection</i> in Park Brake. Is the parking brake drum worn?	—	Go to Step 18	Go to Step 19
18	Replace the parking brake drum. Refer to <i>Brake Drum Replacement</i> in Park Brake. Is roughness or vibration still evident?	—	Go to Step 19	System OK
19	Inspect the rear joint angle. Refer to <i>Diagnosing Second-Order Driveline Vibration</i> in Vibration Diagnosis and Correction. Is the angle too large or too small?	—	Go to Step 20	Go to Step 21
20	Correct the rear joint angle. Is roughness or vibration still evident?	—	Go to Step 21	System OK
21	Inspect the slip yoke spline. Is the slip yoke spline excessively loose?	—	Go to Step 22	Go to Step 23
22	Replace the parts as necessary. Is roughness or vibration still evident?	—	Go to Step 23	System OK
23	Inspect the yokes. Are the yokes distorted or damaged?	—	Go to Step 24	Go to Step 25
24	Install the new yokes. Is roughness or vibration still evident?	—	Go to Step 25	System OK
25	Inspect for propeller shaft phasing. Refer to <i>Diagnosing Second-Order Driveline Vibration</i> in Vibration Diagnosis and Correction. Are the yokes out of parallel to each other?	—	Go to Step 26	Go to Step 27
26	Correct the propeller shaft phasing. Is roughness or vibration still evident?	—	Go to Step 27	System OK
27	Inspect the propeller shaft. Is there dirt or debris on the propeller shaft?	—	Go to Step 28	Go to Step 29
28	Clean the propeller shaft. Is roughness or vibration still evident?	—	Go to Step 29	System OK
29	Inspect the propeller shaft. Is the propeller shaft bent or dented?	—	Go to Step 30	—
30	Replace the propeller shaft. Refer to <i>Propeller Shaft Replacement (One-Piece)</i> or <i>Two-Piece Propeller Shaft Replacement</i> or <i>Three-Piece Propeller Shaft Replacement</i> . Is roughness or vibration still evident?	—	—	System OK

**Ping, Snap, or Click Noise**

Problem	Action
DEFINITION: A ping, snap or click is usually heard on initial load after the transmission is in gear, either forward or reverse.	
The rear springs or upper and lower control arms have loose bushing bolts.	Tighten the bolts to specified torque. Refer to <i>Fastener Tightening Specifications</i> .
A loose fixed yoke or companion flange.	Tighten the bolts and pinion nut to specified torque. Refer to <i>Fastener Tightening Specifications</i> .
Worn or damaged universal joints.	Replace the universal joints. Refer to <i>Universal Joints Replacement</i> .

**Knock or Clunk Noise**

Problem	Action
DEFINITION: Knocking or clunking noise occurs when operating the vehicle in high gear or coasting in neutral at 16 km/h (10 mph).	
A worn or damaged universal joint.	Replace the worn or damaged universal joint.
The side gear hub counterbore in the differential is worn oversize.	Replace the differential case and/or the side gears.

**Scraping Noise**

Problem	Action
DEFINITION: A scraping noise occurs when driving the vehicle at various speeds.	
The pinion flange, or center bearing is rubbing.	Correct the interference.

**Squeak Noise**

Problem	Action
DEFINITION: When driving the vehicle at various speeds a squeaking sound occurs.	
Lack of lubricant.	Replace the universal joints as required. Refer to <i>Universal Joints Replacement</i> .

**Shudder on Acceleration at Low Speed**

Problem	Action
DEFINITION: When accelerating the vehicle at low speed a shudder occurs.	
The bolts are loose or missing at the flanges.	Replace or tighten the bolts to specified torque. Refer to <i>Fastener Tightening Specifications</i> .
The joint angle is excessive or incorrectly set.	Shim under the transmission support mount in order to change the joint angle. Use the standard shim P/N 1254001, or shim the axle pinion down.
The universal joint is worn.	Replace the universal joint. Refer to <i>Universal Joints Replacement</i> .

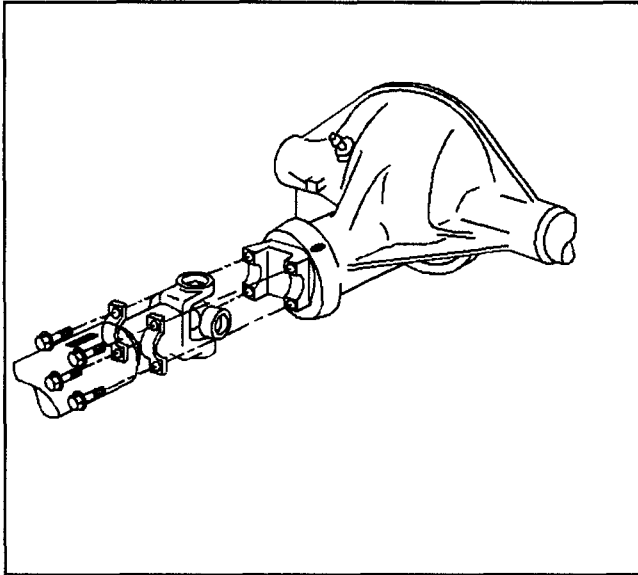

1247

## Repair Instructions

### Propeller Shaft Replacement (One-Piece)

#### Removal Procedure

**Important:** Observe the position of all the driveline components. Accurately mark the relationship of the components before removal. These components include the propeller shafts, the drive axles, the pinion flanges, and the output shafts. All components must be reassembled in the exact relationship to each other as they were before removal. Follow the specifications, the torque values, and any measurements made prior to disassembly.

1. Raise the vehicle on a hoist.
2. Accurately reference mark the propeller shaft.
3. Remove the bolts from the rear of the pinion flange.
4. Remove the retainers.

**Important:** Do not pound on the original propeller shaft yoke ears. The injection joints may fracture. Never pry or place any tool between a yoke and a universal joint.

5. Remove the yoke and cross assembly.
6. Tape the bearing cups in order to prevent the loss of bearing rollers.
7. Remove the propeller shaft by using the following procedure:
  - 7.1. Slide the propeller shaft forward.
  - 7.2. Lower the propeller shaft, and remove the shaft under the rear axle.
  - 7.3. Do not allow the universal joint to incline greatly; the joint may fracture.
8. Clean all the parts with a suitable solvent.
9. Inspect the outer diameter of the nylon injected yoke for burrs. Burring damages the transmission seal.
10. Inspect for proper installation and uniform seating of the bearing cups.
11. Inspect the slip yoke splines for wear.
12. Inspect for twisted slip yoke splines or possibly the wrong universal joint. Replace the parts as necessary.

### Installation Procedure

1. Install the propeller shaft into the transmission.

**Important:** Install a new universal joint whenever a slip joint or companion flange is serviced.

2. Lubricate the slip joint.
3. Install the yoke and cross assembly onto the pinion flange.
4. Align the reference marks on the pinion flange and the propeller shaft rear yoke. Seat the yoke properly.
5. Install the retainers.

**Notice:** Refer to *Fastener Notice* in Cautions and Notices.

6. Install the bolts into the pinion flange.

#### Tighten

- Tighten the bolts to 44 N·m (33 lb ft) if equipped with transmission mounted parking brake.
- Tighten the bolts to 20 N·m (15 lb ft) if not equipped with transmission mounted parking brake.

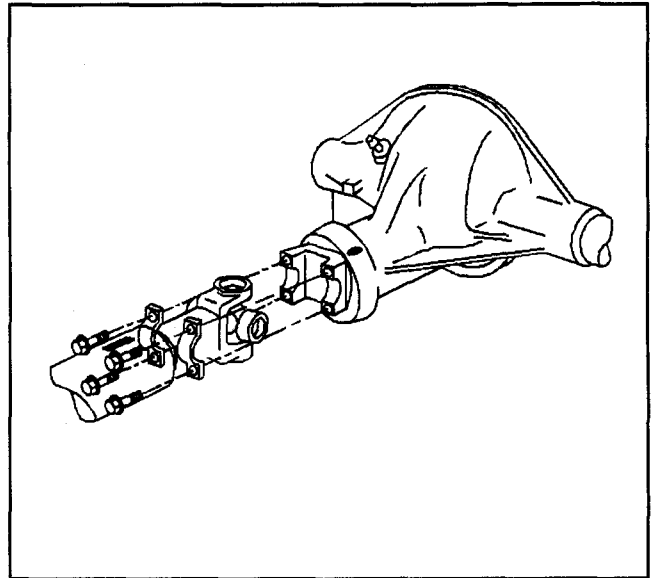

1247

### Two-Piece Propeller Shaft Replacement

#### Removal Procedure

1. Raise the vehicle and support with safety stands. Refer to *Lifting and Jacking the Vehicle* in General Information.

**Important:** You must observe and accurately reference mark the positions of all driveline components relative to the propeller shaft and axles prior to disassembly. These components include the propeller shafts, drive axles, pinion flanges, and output shafts. All components must be reassembled in the exact relationship to each other as they were when removed. In addition you must follow published specifications and torque values as well as any measurements made prior to disassembly. Reference mark the rear propeller shaft to the pinion flange and to the front propeller shaft, then reference mark the front shaft to the yoke at the transmission.

2. Remove the bolts at the pinion flange.
3. Remove the retainers at the pinion flange.
4. Loosen the cap retainer.

**Important:** Do not pound on the original propeller shaft yoke ears. The plastic injection joints may fracture. Never pry or place any tool between a yoke and a universal joint. Tape the bearing cups onto the yoke and universal joints in order to prevent loss of the needle bearings. Slide the propeller shaft forward in order to disengage the rear universal joint from the pinion flange. Then slide the shaft rearward off the front propeller shaft splines.

5. Remove the rear propeller shaft.

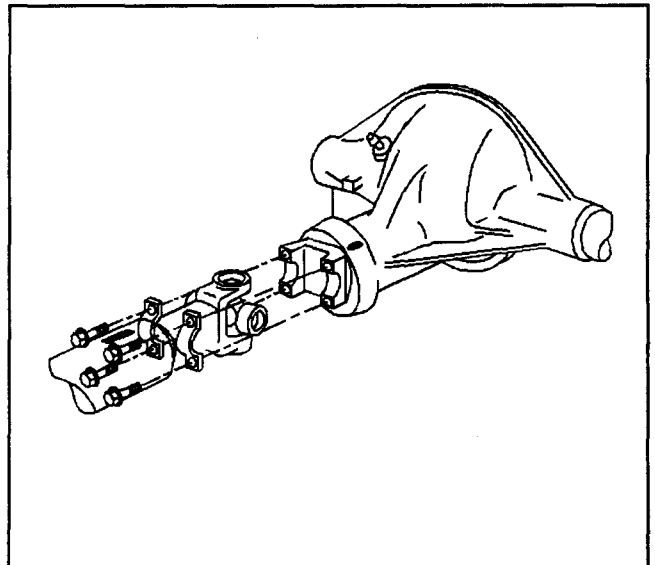

1247



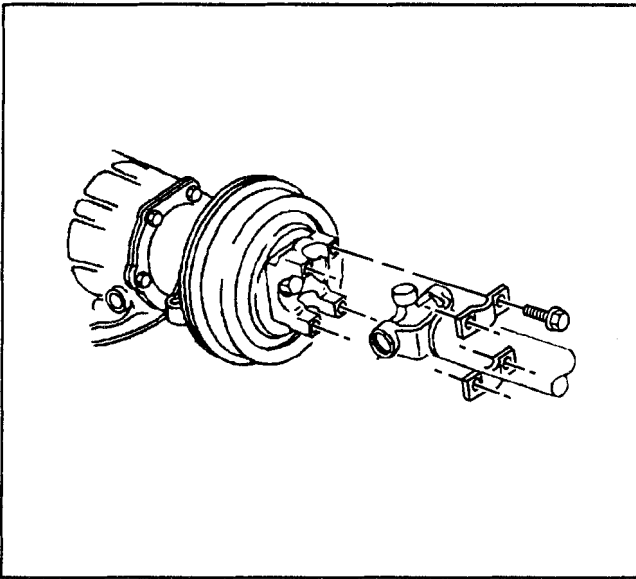

175615

6. Remove the bolts at the yoke.
7. Remove the retainers at the yoke.

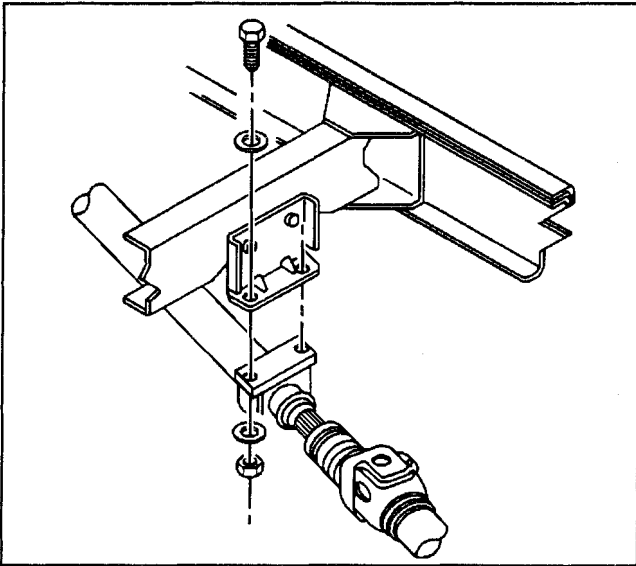

305537

8. Remove the nuts from the front propeller shaft center bearing support attaching bolts.
9. Remove the bolts and washers.
10. Remove the front propeller shaft with the center bearing support from the vehicle.
11. Clean all parts with an approved solvent.
12. Inspect the outer diameter of the transmission yoke for burrs.
13. Inspect for proper installation and uniform seating of the bearing cups.
14. Inspect for twisted slip yoke splines or possibly the wrong universal joint.

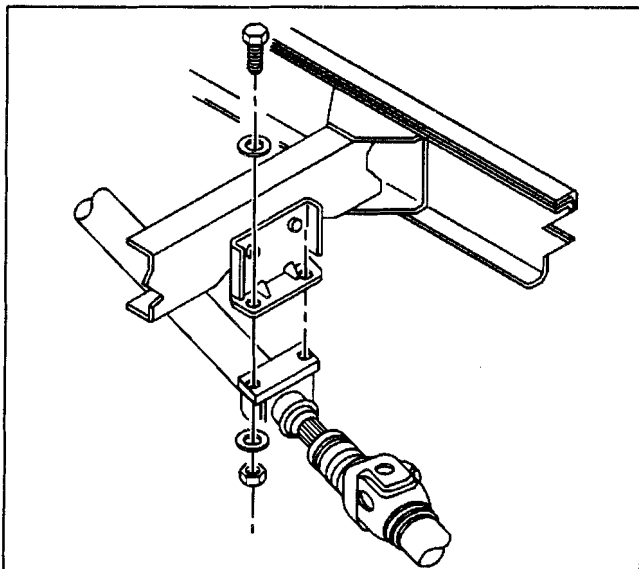

305537

### Installation Procedure

**Notice:** Refer to *Fastener Notice* in Cautions and Notices.

1. Install the bolts, washers, and nuts at the center bearing support to the crossmember.

#### Tighten

Tighten the center bearing support bolts to 53 N·m (39 lb ft).

2. Lining up the reference marks, install the front propeller shaft up against the yoke.

**Notice:** Refer to *Fastener Notice* in Cautions and Notices.

3. Install the retainers and bolts.

#### Tighten

- Tighten the bolts (at the axle end) to 20 N·m (15 lb ft) (without the transmission mounted drum parking brake).
- Tighten the bolts (at the axle end) to 28 N·m (21 lb ft) (with the transmission mounted drum parking brake).

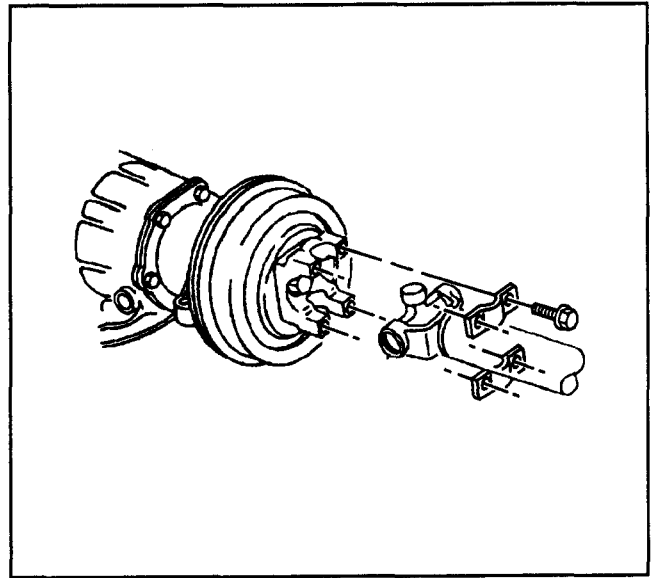

175615

4. Install the rear propeller shaft, lining up the reference marks.
  - Slide the front end of the shaft onto the splines of the front shaft.
  - Slide the front end of the shaft far enough forward in order to allow the rear universal joint to engage the pinion flange.
5. Set the seal in place and secure the cap retainer onto the rear shaft.
6. Install the retainers.
7. Install the bolts.

#### Tighten

- Tighten the bolts (at the axle end) to 20 N·m (15 lb ft) (without the transmission mounted drum parking brake).
- Tighten the bolts (at the axle end) to 44 N·m (33 lb ft) (with the transmission mounted drum parking brake).

8. Remove the safety stands and lower the vehicle.

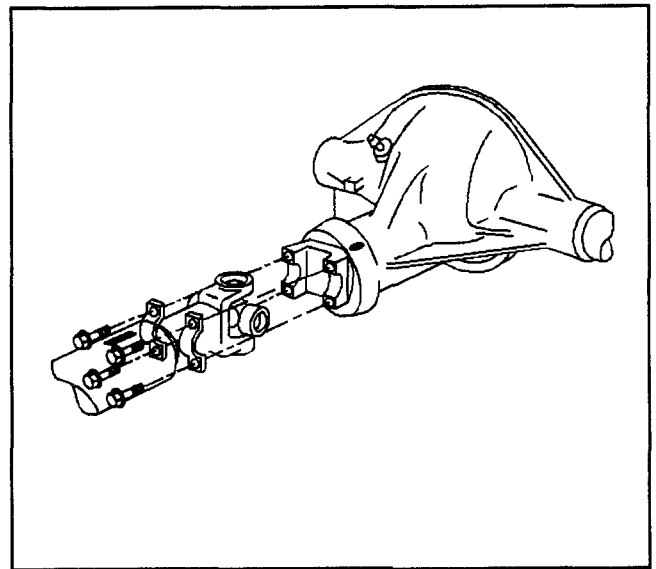

1247

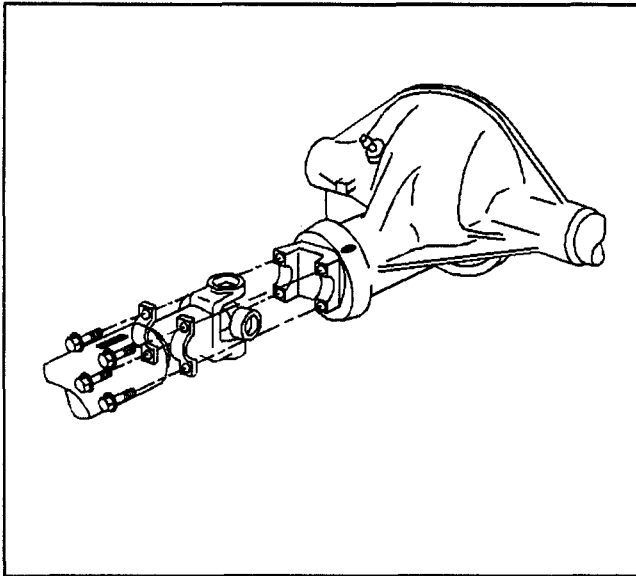

1247

## Three-Piece Propeller Shaft Replacement

### Removal Procedure

1. Raise the vehicle on a hoist. Refer to *Lifting and Jacking the Vehicle* in General Information.

**Important:** You must observe and accurately reference mark the positions of all driveline components relative to the propeller shaft and axles prior to disassembly. These components include the propeller shafts, drive axles, pinion flanges, and output shafts. All components must be reassembled in the exact relationship to each other as they were when removed. In addition you must follow published specifications and torque values as well as any measurements made prior to disassembly. Reference mark the rear propeller shaft to the pinion flange and to the front propeller shaft, then reference mark the front shaft to the yoke at the transmission. Support the rear propeller shaft.

2. Remove the cap retainer from the rear propeller shaft at the intermediate propeller shaft connection.
3. Remove the bolts from the pinion flange.
4. Remove the retainers.
5. Remove the yoke and the universal joint assembly from the pinion flange.

**Important:** Do not pound on the original propeller shaft yoke ears. The plastic injection joints may fracture. Never pry or place any tool between a yoke and a universal joint. Tape the bearing cups onto the yoke in order to prevent the loss of bearing rollers.

6. Remove the rear propeller shaft.
  - Slide the rear propeller shaft forward.
  - Lower the rear propeller shaft and withdraw under the rear axle.
  - Do not allow the universal joint assembly to incline greatly. The joint may fracture.
  - Reference mark the intermediate propeller shaft to front propeller shaft yoke.
  - Support the intermediate propeller shaft.

7. Remove the nuts from the intermediate shaft center bearing support attaching bolts.
8. Remove the bolts and washers.

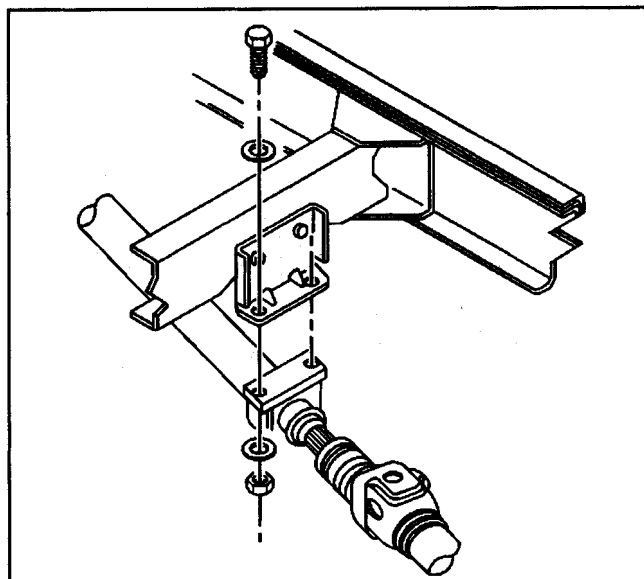

305537

9. Remove the intermediate propeller shaft center bearing support from the hanger.
10. Remove the bolts from the front propeller shaft yoke at the front center bearing support.
11. Remove the yoke and the universal joint assembly from the front propeller shaft rear yoke.

**Important:** Do not pound on the original propeller shaft yoke ears. The plastic injection joints may fracture. Never pry or place any tool between a yoke and a universal joint. Tape the bearing cups onto the yoke and universal joints in order to prevent loss of the needle bearings.

12. Remove the intermediate propeller shaft.
  - Reference mark the front propeller shaft to the yoke or parking brake drum.
  - Support the front propeller shaft.

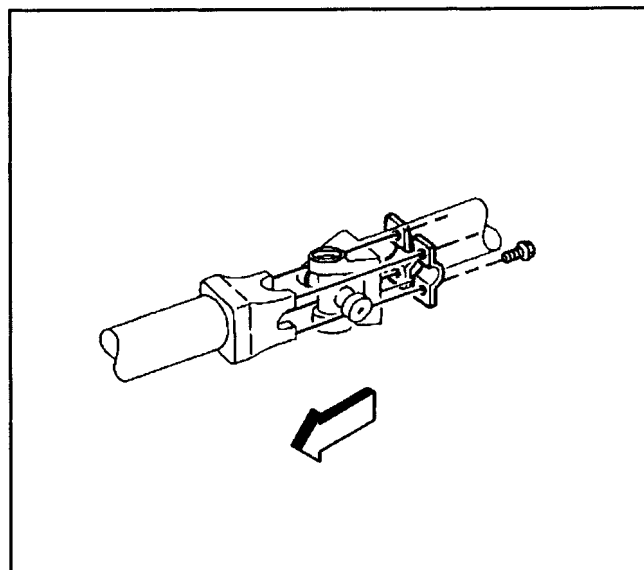

305529

13. Remove the nuts from the front propeller shaft center bearing support attaching bolts.
14. Remove the bolts and washers.
15. Remove the front propeller shaft center bearing support from the hanger.

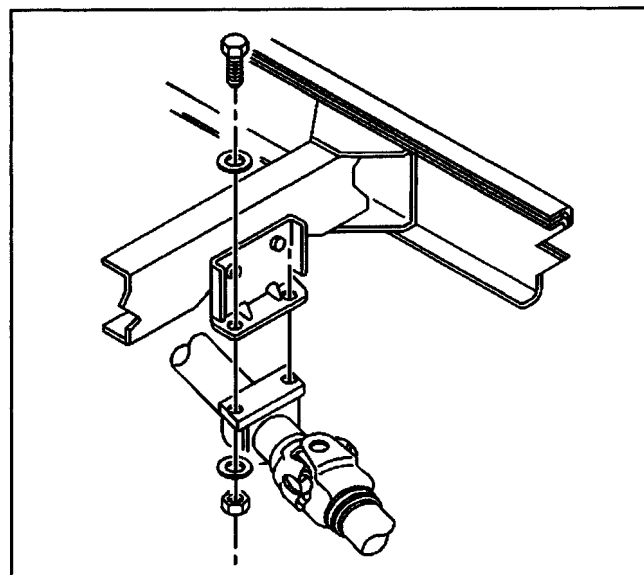

305527

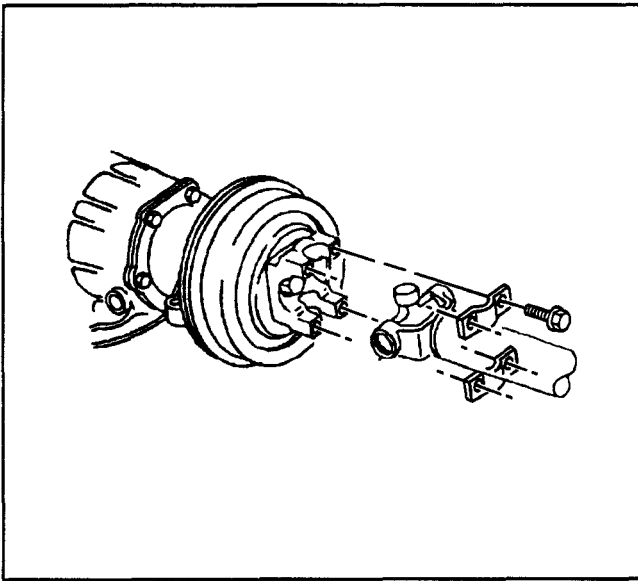

175615

16. Remove the bolts and retainers from the yoke.

17. Remove the universal joint assembly from the transmission yoke.

**Important:** Do not pound on the original propeller shaft yoke ears. The plastic injection joints may fracture. Never pry or place any tool between a yoke and a universal joint. Tape the bearing cups onto the yoke in order to prevent the loss of bearing rollers.

18. Remove the front propeller shaft.

19. Clean all parts with an approved solvent.

20. Inspect for proper installation and uniform seating of all universal joint bearing cups.

21. Inspect the intermediate propeller shaft to rear propeller shaft slip yoke splines for twisting or wear.

22. Inspect the inside of the rear propeller shaft slip yoke for spline twisting or wear.

23. Inspect the front and rear center bearing support rubber insulators for deterioration or separation from the support framework.

24. Inspect the propeller shaft assemblies for damage.

### Installation Procedure

1. Install the front propeller shaft to the yoke.

- Make sure the reference marks are aligned.
- Support the front propeller shaft.

**Notice:** Refer to *Fastener Notice* in Cautions and Notices.

2. Install the bolts and retainers to the yoke.

#### Tighten

- Tighten the bolts to 20 N·m (15 lb ft) (without transmission mounted drum parking brake).
- Tighten the bolts to 28 N·m (21 lb ft) (with transmission mounted drum parking brake).

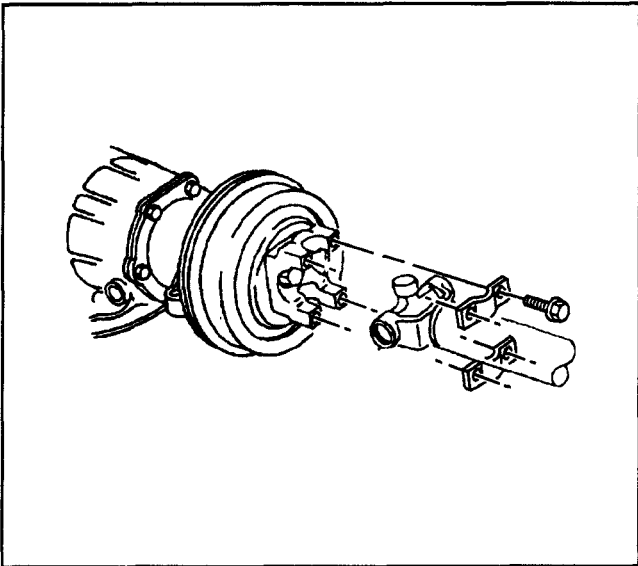

175615

3. Install the front center bearing support to hanger.
4. Align the center bearing support 90 degrees to the propeller shaft center line.
5. Install the bolts.
6. Install the washers and nuts.

**Tighten**

Tighten the nuts to 53 N·m (39 lb ft). Maintain alignment.

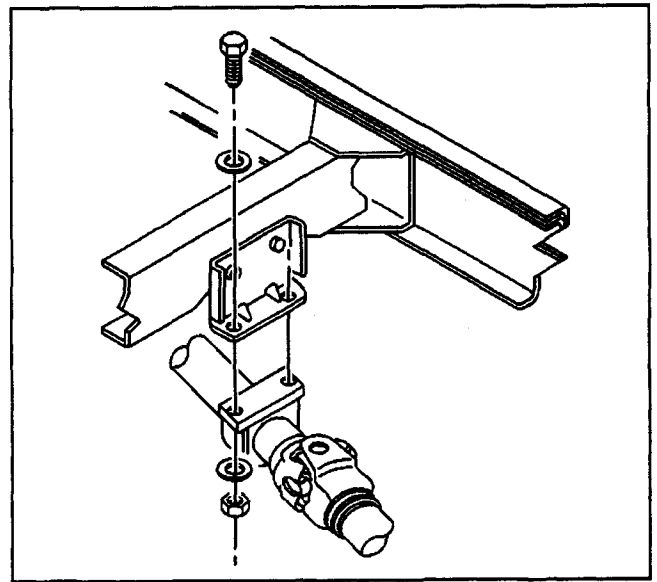

305527

7. Install the intermediate propeller shaft to the front propeller shaft yoke.
  - Make sure reference marks are aligned.
  - Support the intermediate propeller shaft.
8. Install the bolts and retainers.

**Tighten**

Tighten the bolts to 44 N·m (33 lb ft).

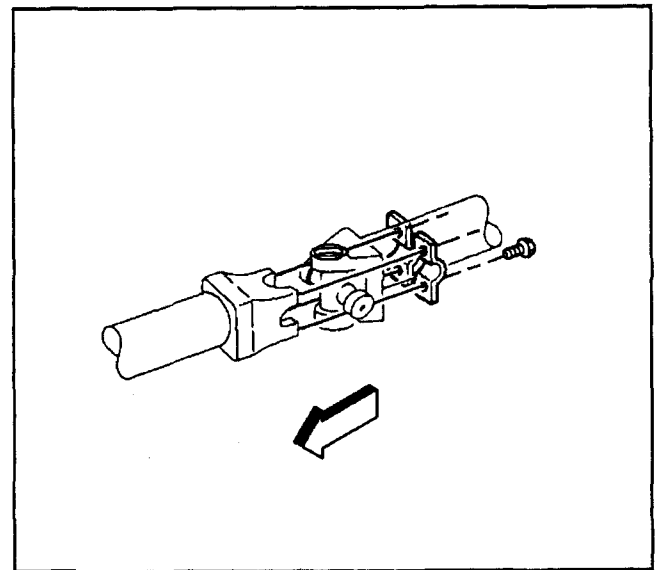

305529

9. Install the rear center bearing support to hanger.
10. Align the center bearing support 90 degrees to both the front and intermediate propeller shaft center lines.
11. Install the bolts and washers.

**Tighten**

Tighten the nuts to 53 N·m (39 lb ft). Maintain alignment.

12. Install the rear propeller shaft slip yoke to the intermediate propeller shaft splines.
  - Mate the missing tooth (some models) in the rear propeller shaft slip yoke with the bridged tooth on the intermediate propeller shaft.
  - Support the rear propeller shaft.

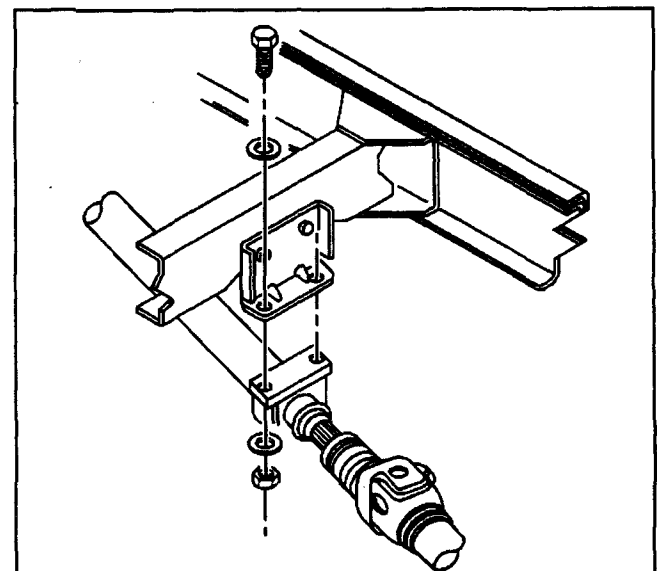

305537

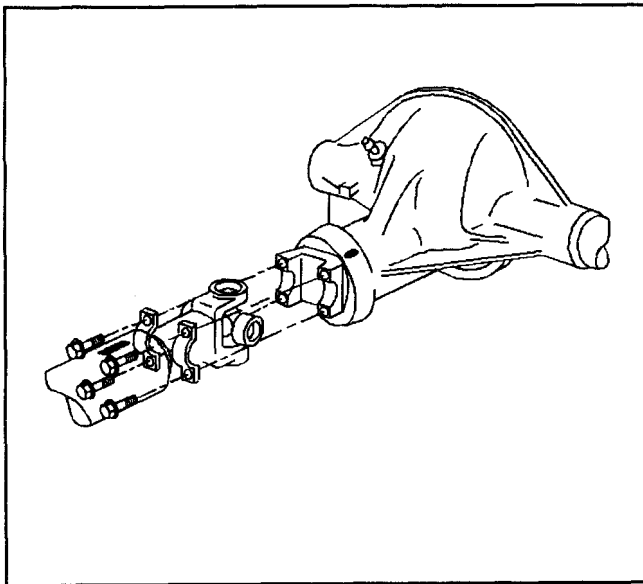

1247

13. Install the rear propeller shaft to rear axle pinion flange. Make sure the reference marks are aligned.
14. Install the bolts and retainers.

**Tighten**

- Tighten the bolts to 20 N·m (15 lb ft) (without transmission mounted drum parking brake).
  - Tighten the bolts to 44 N·m (33 lb ft) (with transmission mounted drum parking brake).
15. Install the cap retainer.
  16. Remove the safety stands and lower the vehicle.
  17. Lubricate the rear propeller shaft slip yoke and all universal joints.

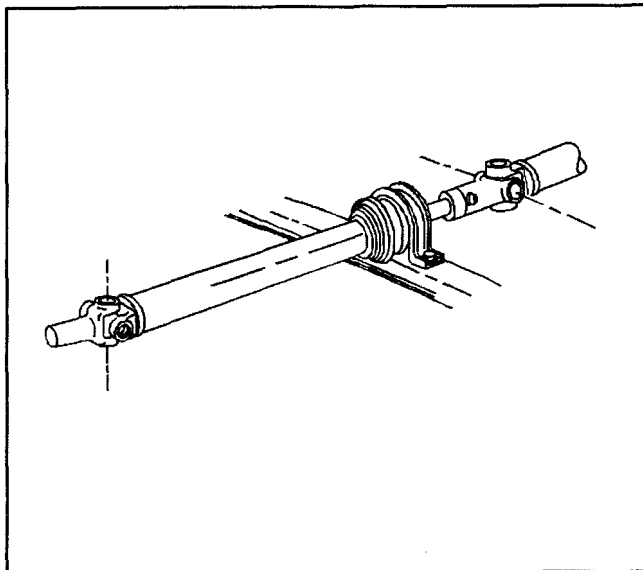

1236

**Center Bearing Replacement****Removal Procedure**

1. Raise the vehicle and support the vehicle with safety stands. Refer to *Lifting and Jacking the Vehicle* in General Information.
2. Remove the rear propeller shaft. Refer to *Two-Piece Propeller Shaft Replacement* or *Three-Piece Propeller Shaft Replacement*.
3. Remove the front or intermediate propeller shaft.
4. Remove the center bearing.
  - Stand the propeller shaft on end in press with the center bearing supported by press bars.
  - Press the propeller shaft down and off the center bearing.

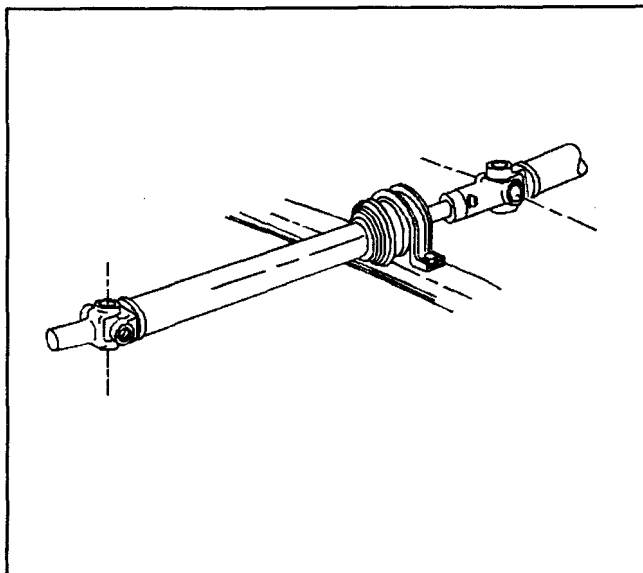

1236

**Installation Procedure**

1. Install the center bearing onto the propeller shaft.
2. Use a press in order to press the center bearing onto the propeller shaft.
3. Install the front or immediate propeller shaft.

**Notice:** Refer to *Fastener Notice* in Cautions and Notices.

**Important:** The center bearing must be aligned in order to prevent damage to the propeller shaft assembly. When bolting the center bearing in place, be sure to keep it perpendicular 89–91 degrees to the propeller shaft.

4. Install the rear propeller shaft. Refer to *Two-Piece Propeller Shaft Replacement* or *Three-Piece Propeller Shaft Replacement*.

#### Tighten

Tighten the center bearing bolts/nuts to 53 N·m (39 lb ft).

5. Remove the safety stands and lower vehicle.

## Yoke Replacement (Manual Transmission)

### Removal Procedure

1. Raise and suitably support the vehicle. Refer to *Lifting and Jacking the Vehicle* in General Information.
2. Remove the propeller shaft. Refer to *Propeller Shaft Replacement (One-Piece)*

**Important:** Cap the end of the transmission in order to minimize fluid loss.

3. Remove the bolts and retainers.
4. Remove the bolt and washer.
5. Remove the yoke.
6. Inspect the splines for wear, burrs, or twisting.
7. Inspect the yoke ears for damage.

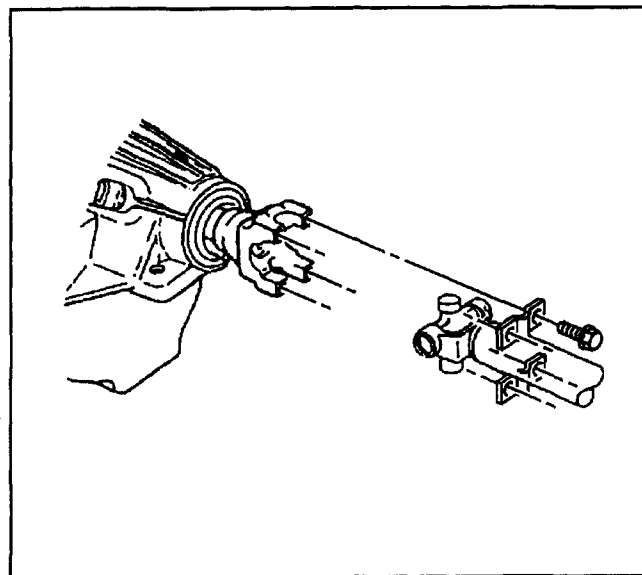

363562

### Installation Procedure

1. Install the front yoke.

**Notice:** Refer to *Fastener Notice* in Cautions and Notices.

2. Install the washer and bolt.

#### Tighten

Tighten the bolt to 110 N·m (81 lb ft).

3. Install the retainers and bolts.

#### Tighten

Tighten the bolts to 20 N·m (15 lb ft).

4. Install the propeller shaft. Refer to *Propeller Shaft Replacement (One-Piece)*.
5. Remove the safety stand, and lower the vehicle.
6. Inspect the transmission fluid level. Refer to *Fluid Replacement* in Manual Transmission.

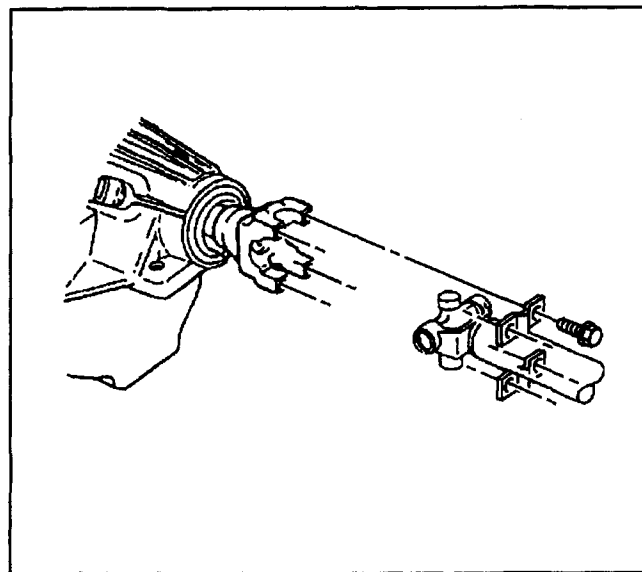

363562



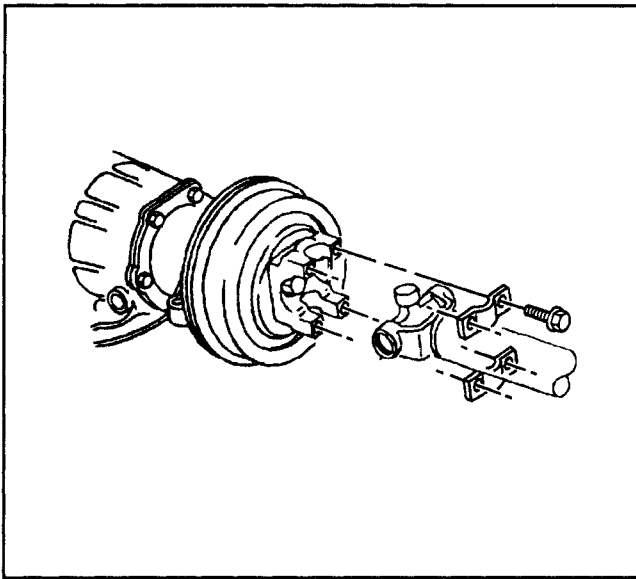

175615

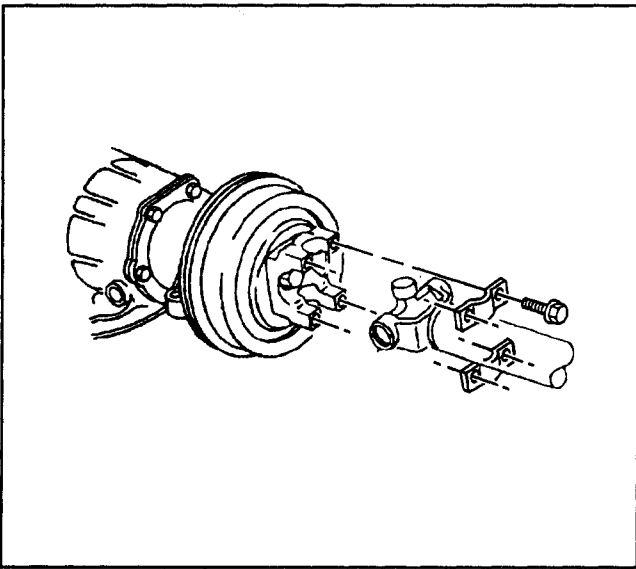

175615

## Yoke Replacement (With Mounted Park Brake)

### Removal Procedure

1. Raise and suitably support the vehicle. Refer to *Lifting and Jacking the Vehicle* in General Information.

**Important:** On two or three-piece propeller shafts, the front yoke is bolted to the tailshaft.

2. Remove the propeller shaft. Refer to *Two-Piece Propeller Shaft Replacement* or *Three-Piece Propeller Shaft Replacement*.
3. Remove the bolt and washer from the center of the yoke.

**Important:** Cap the end of the transmission in order to minimize fluid loss.

4. Remove the park brake drum and yoke assembly from the transmission.
5. Remove the bolts holding the drum to the yoke.
6. Inspect the splines for wear, burrs, or twisting.
7. Inspect the yoke ears for damage.

### Installation Procedure

**Notice:** Refer to *Fastener Notice* in Cautions and Notices.

1. Install the bolts holding the drum to the yoke.

#### Tighten

Tighten the bolts to 40 N·m (30 lb ft).

2. Install the drum and yoke assembly to the transmission.
3. Install the new washer and bolt to the transmission mainshaft at the center of the yoke.

#### Tighten

Tighten the bolt to 110 N·m (81 lb ft).

4. Install the propeller shaft. Refer to *Two-Piece Propeller Shaft Replacement* or *Three-Piece Propeller Shaft Replacement*.
5. Remove the safety stand, and lower the vehicle.
6. Inspect the transmission fluid level. Refer to *AT Fluid/Filter Changing*

## Yoke Replacement (Automatic Transmission )

### Removal Procedure

1. Raise and suitably support the vehicle. Refer to *Lifting and Jacking the Vehicle* in General Information.

**Important:** On two or three-piece propeller shafts, the front yoke is bolted to the tailshaft.

2. Remove the propeller shaft. Refer to *Two-Piece Propeller Shaft Replacement* or *Three-Piece Propeller Shaft Replacement*.
3. Remove the bolt and washer.

**Important:** Cap the end of the transmission in order to minimize fluid loss.

4. Remove the yoke.
5. Inspect the splines for wear, burrs, or twisting.
6. Inspect the yoke ears for damage.

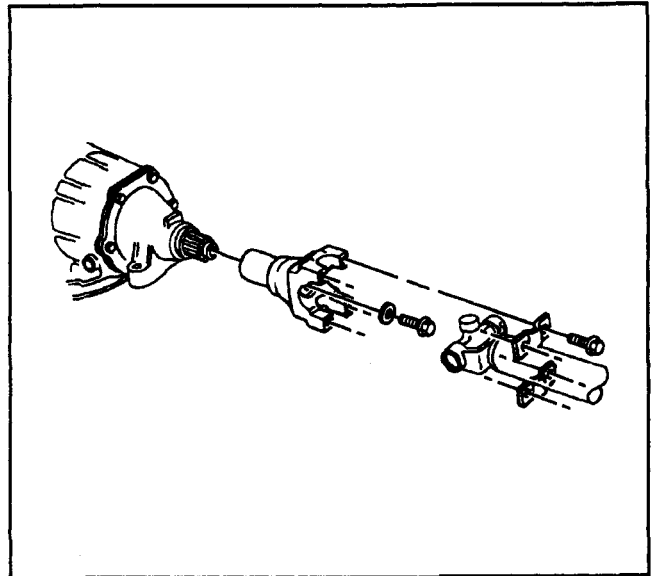

175622

### Installation Procedure

1. Install the front yoke.

**Notice:** Refer to *Fastener Notice* in Cautions and Notices.

2. Install the washer and bolt.

#### Tighten

Tighten the bolt to 110 N·m (81 lb ft).

3. Install the propeller shaft. Refer to *Two-Piece Propeller Shaft Replacement* or *Three-Piece Propeller Shaft Replacement*.
4. Remove the safety stand, and lower the vehicle.
5. Inspect the transmission fluid level. Refer to *AT Fluid/Filter Changing*.

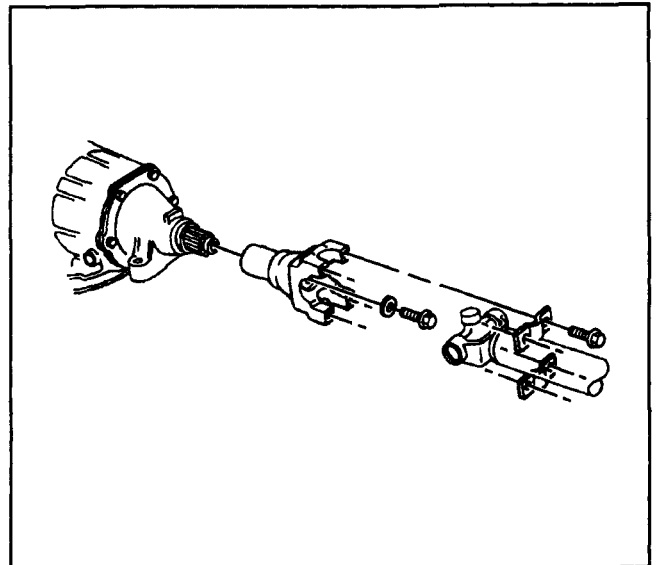

175622

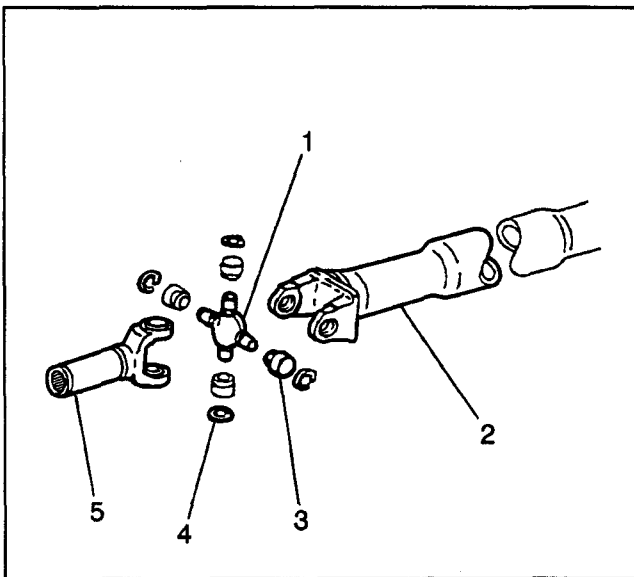

159400

## Universal Joints Replacement

### Removal Procedure

1. Raise and support the vehicle with safety stands. Refer to *Lifting and Jacking the Vehicle* in General Information.
2. Remove the propeller shaft. Refer to *Propeller Shaft Replacement (One-Piece)* or *Two-Piece Propeller Shaft Replacement* or *Three-Piece Propeller Shaft Replacement*.
3. Remove the retainer rings (4).

**Important:** Do not pound on the yoke ears of the propeller shaft or the slip yoke. Pounding on the yoke ears may damage the components.

4. Remove the bearing cups (3) from the propeller shaft (2).
  - Using two sockets (one with a diameter just smaller than the bearing cup, the other with an opening large enough to accept a bearing cup) drive out the bearing cups by pressing them out using a vise or press.
  - If you are replacing the rear universal joint, go to step 1 of the installation procedure.
  - If you are replacing the front universal joint, repeat the first part of step 3 in order to remove the bearing cups from the slip yoke (5).

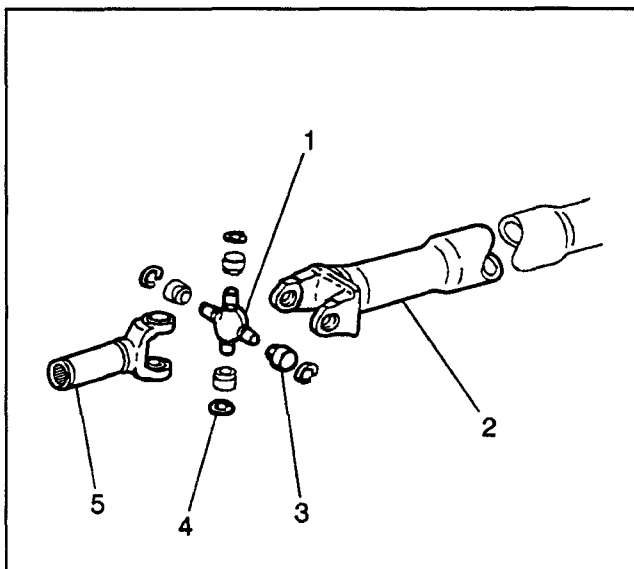

159400

### Installation Procedure

1. Install the bearing cups.
  - Set the trunnion (1) in between the yoke ears of the propeller shaft (2) and start installing both bearing cups (3) by hand. Continue driving the bearing cups inward by squeezing the bearing cups together using a press or vise.
  - Use a socket with a smaller diameter than the cup and drive the cup past the retainer ring groove.
2. Install the retainer ring (4).
  - Turn the shaft over.
  - Drive the opposite bearing cup past the retainer ring groove.
3. Install the retainer ring.
4. Set the slip yoke (5) over the trunnion and install as outlined in steps 1–3.
5. Install the propeller shaft. Refer to *Propeller Shaft Replacement (One-Piece)* or *Two-Piece Propeller Shaft Replacement* or *Three-Piece Propeller Shaft Replacement*.
6. Remove the safety stands and lower the vehicle. Refer to *AT Fluid/Filter Changing*

## Description and Operation

### Propeller Shaft Description

Torque is transmitted from the transmission to the axle through one, two, or three propeller shafts and universal joint assemblies. The number of propeller shafts and universal joint assemblies vary with the vehicle wheel base. All propeller shafts are the balanced tubular type.

### Balancing Information

There are two different methods for achieving balance within the propeller shaft system during the manufacturing process. Vehicles that have one or two propeller shafts have those shafts balanced individually. Vehicles that have three propeller shafts utilize a system balance. System balance is accomplished by effectively balancing the front, center, and rear propeller shafts together on a special balancing machine. When manufactured, the three-piece propeller shaft system and the transmission mounted parking brake assembly are aligned with arrows painted on the shafts.

### Propeller Shaft Phasing Description

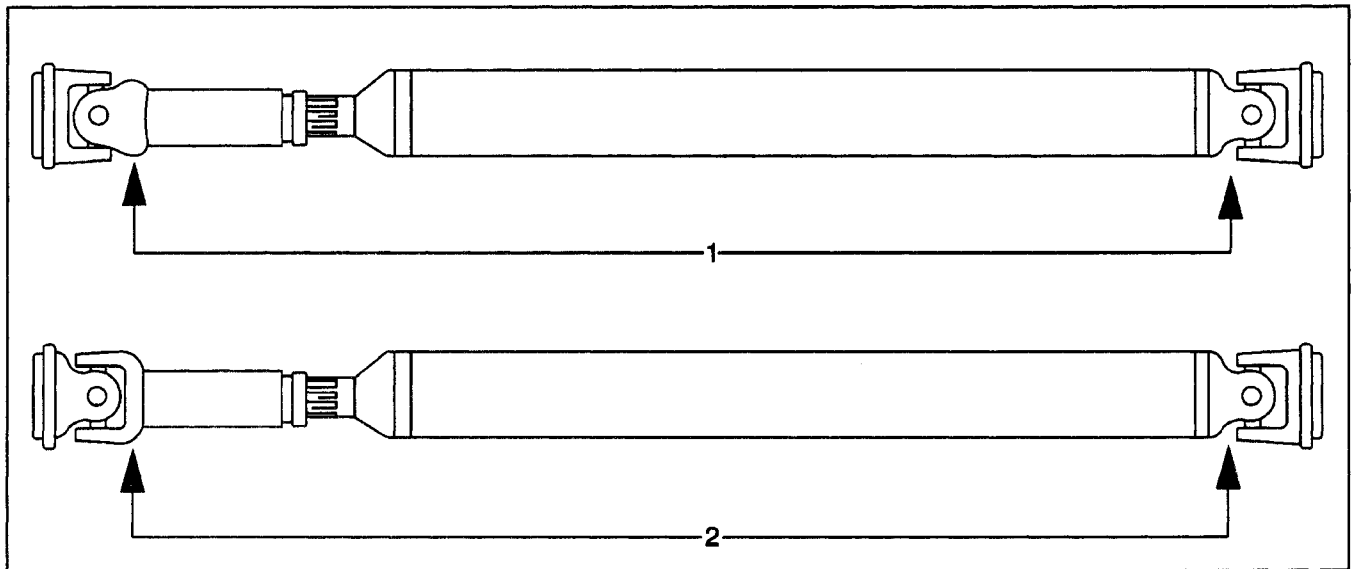

191253

The propeller shaft is designed and built with the yoke lugs (ears) in line with each other (1). Having the yoke lugs in line with each other produces the smoothest running shaft possible, and is called phasing.

An out-of-phase propeller shaft can cause vibration (2). The propeller shaft absorbs vibrations from speeding up and slowing down each time the universal joint rotates. Vibration is the same as a person snapping a rope and watching the wave reaction flow to the end. A propeller shaft working in phase would be similar to two persons snapping a rope at the same time, and watching the waves meet and cancel each other out.

In order to insure that these parts are assembled in proper relation to each other, mark all components before disassembly. Minimizing driveline imbalance in a three-piece propeller shaft system is critical for maintaining the lowest vibrational noise possible. When servicing a three-piece propeller shaft system, take special care that proper balance is maintained. In the event that a single propeller shaft within a three-piece propeller shaft system required replacement, follow one of the following procedures in order to properly balance the three-piece propeller shaft system:

- Consider replacement of all three propeller shafts in the system by ordering the three-piece propeller shaft assembly.
- Replace damaged or worn propeller shaft (prebalanced as received) and rebalance the remaining shafts individually or as a system.
- Replace damaged or worn propeller shaft (prebalanced as received) and evaluate the resulting driveline. If necessary, correct remaining propeller shaft imbalance by using procedures in Vibration Diagnosis in General Information.

In comparison the rope illustration is the same as the universal joints on a propeller shaft. A total cancellation of vibration produces a smooth flow of power in the driveline. You must reference mark the propeller shaft before removal in order to ensure phased installation alignment. Some propeller shafts have keyed splines that keep the propeller shafts in phase during assembly.

### Universal Joint Description

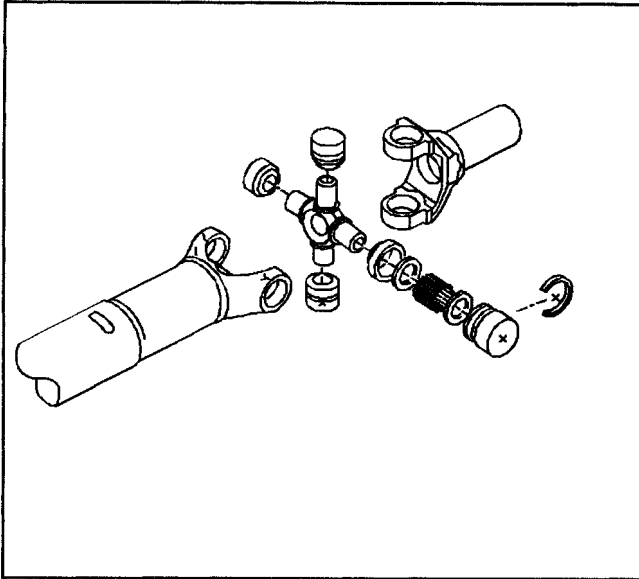

1237

A universal joint consists of two Y-shaped yokes attached to a spider. The spider is shaped like a cross having arms of equal length called trunnions.

Universal joints handle the effects of various loads and axle windup during acceleration. Within the designed angle variations the universal joint operates efficiently and safely. When the design angle changes or is exceeded, the operational life of the joint may decrease.

Needle roller bearings are used in universal joints. Round bearing cups hold the needle rollers in place on the trunnions. Either snap rings or injected plastic, depending on the manufacturer of the joint, hold the bearing cups in the yokes.

### Center Bearing Description

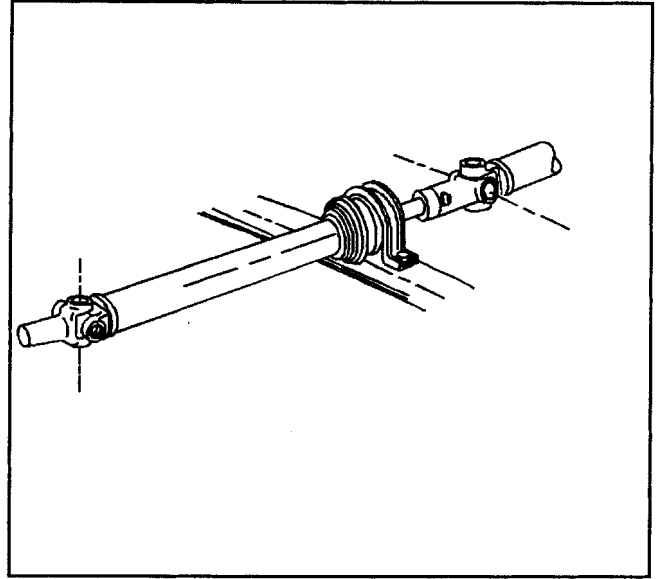

1236

Center bearings support the driveline. The center bearing is a ball-type bearing mounted in a rubber cushion that attaches to a hanger supported by a frame crossmember. The bearing is prelubricated and sealed by the manufacturer.

# Rear Drive Axle

## Specifications

### Fastener Tightening Specifications (American Axle)

Application	Specification	
	Metric	English
Brake Backing Plate	142 N·m	105 lb ft
Carrier Cover	41 N·m	30 lb ft
Filler Plug	24 N·m	18 lb ft
Hub Cap Bolts	156 N·m	115 lb ft
U-Bolt Nuts	205 N·m	151 lb ft

### Fastener Tightening Specifications (Dana)

Application	Specification	
	Metric	English
Brake Backing Plate	203 N·m	150 lb ft
Carrier Cover	47 N·m	35 lb ft
Filler Plug	34 N·m	25 lb ft
Hub Cap Bolts	21 N·m	15 lb ft
Pinion Nut	597–678 N·m	440–500 lb ft
U-Bolt Nuts	205 N·m	151 lb ft

### Rear Axle Specifications

Axle Make	Ring Gear Size	Bearing Adjusting Nut Torque (While Rotating Wheel)		Adjust Nut Back-Off	Outer Locknut Torque
		N·m	Lb ft		
American Axle	10 ½ Inch	68	50	*	—
Dana	11 Inch	68	50	**	88 N·m (65 lb ft) ***

\* Back off until the nut is loose. Rotate the nut up against the shoulder of the bearing cone (zero torque).

\*\* Back off the nut and while rotating the hub, tighten the nut to 54 N·m (40 lb ft). Then back off the nut 135–150 degrees. The final end play is 0.025–0.25 N·m (0.001–0.01 inch).

\*\*\* Assemble the lockwasher and the outer locknut. Tighten the locknut to 88 N·m (65 lb ft). Bend one ear of the lockwasher over the inner nut a minimum of 30 degrees. Bend one ear of the lockwasher over the outer nut a minimum of 60 degrees.

### Lubrication Specifications

Application	Specification	
	Metric	English
American Axle 10½" Ring Gear	3.4 liters	7.2 pints
Dana 80 11" Ring Gear	4 liters	8.2 pints

**Component Locator**

**Rear Axle Disassembled Views (Disc Brakes)**

**Full-Floating Axle Wheel End Components (American Axle)**

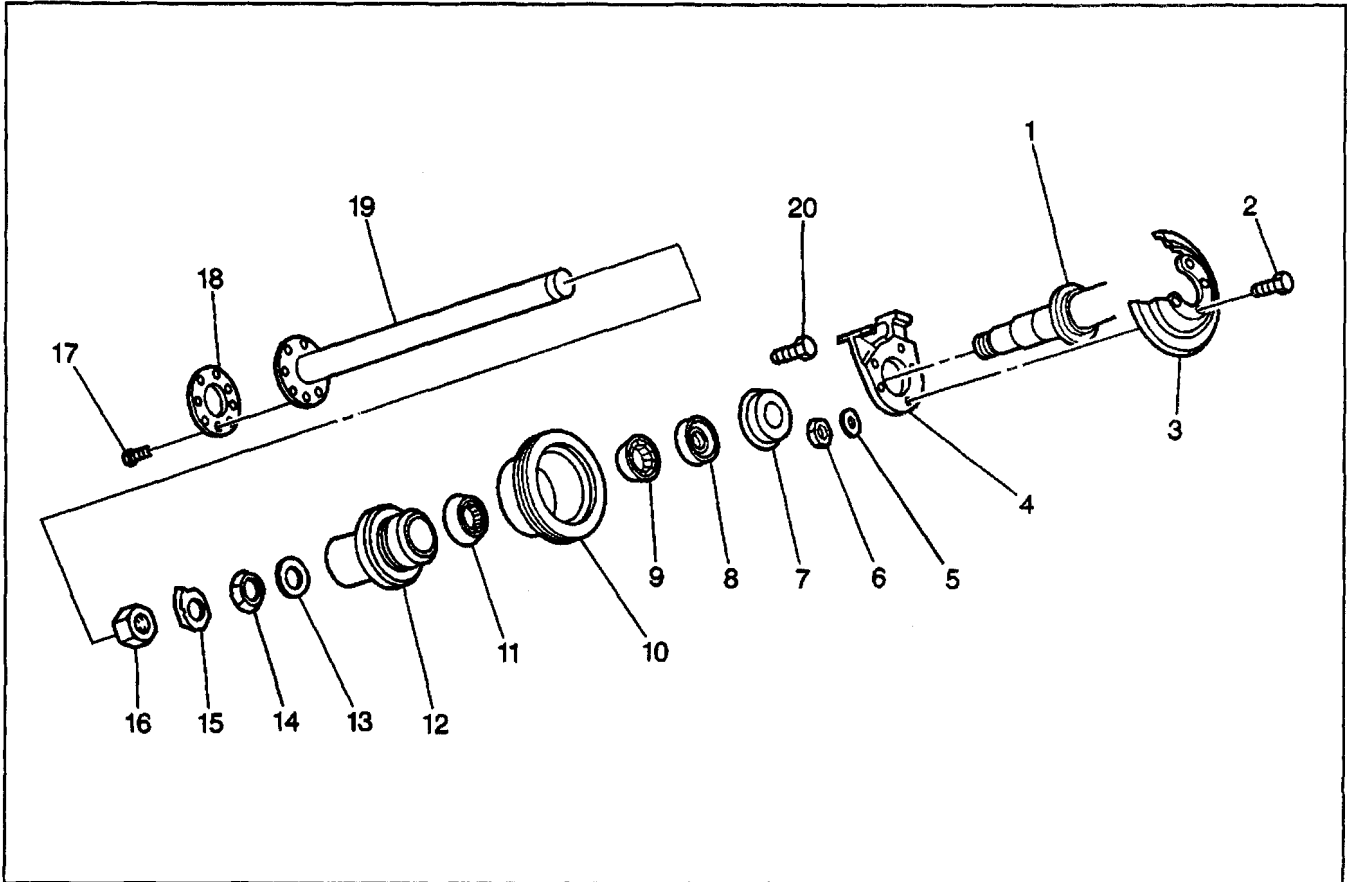

228413

**Legend**

- |                                 |                                      |
|---------------------------------|--------------------------------------|
| (1) Axle Housing                | (11) Rear Wheel Outer Bearing        |
| (2) Backing Plate Mounting Bolt | (12) Rear Wheel Hub                  |
| (3) Backing Plate               | (13) Rear Wheel Bearing Washer       |
| (4) Anchor Plate                | (14) Rear Wheel Bearing Adjuster Nut |
| (5) Washer                      | (15) Lock Washer                     |
| (6) Backing Plate Mounting Nut  | (16) Outer Lock Nut                  |
| (7) Wheel Bearing Oil Deflector | (17) Rear Axle Shaft Bolt            |
| (8) Oil Seal                    | (18) Rear Axle Shaft Mounting Flange |
| (9) Rear Wheel Inner Bearing    | (19) Axle Shaft                      |
| (10) Rear Brake Rotor           | (20) Wheel Hub Bolt                  |

Rear Axle Disassembled Views (Drum Brakes)

Drum Brakes

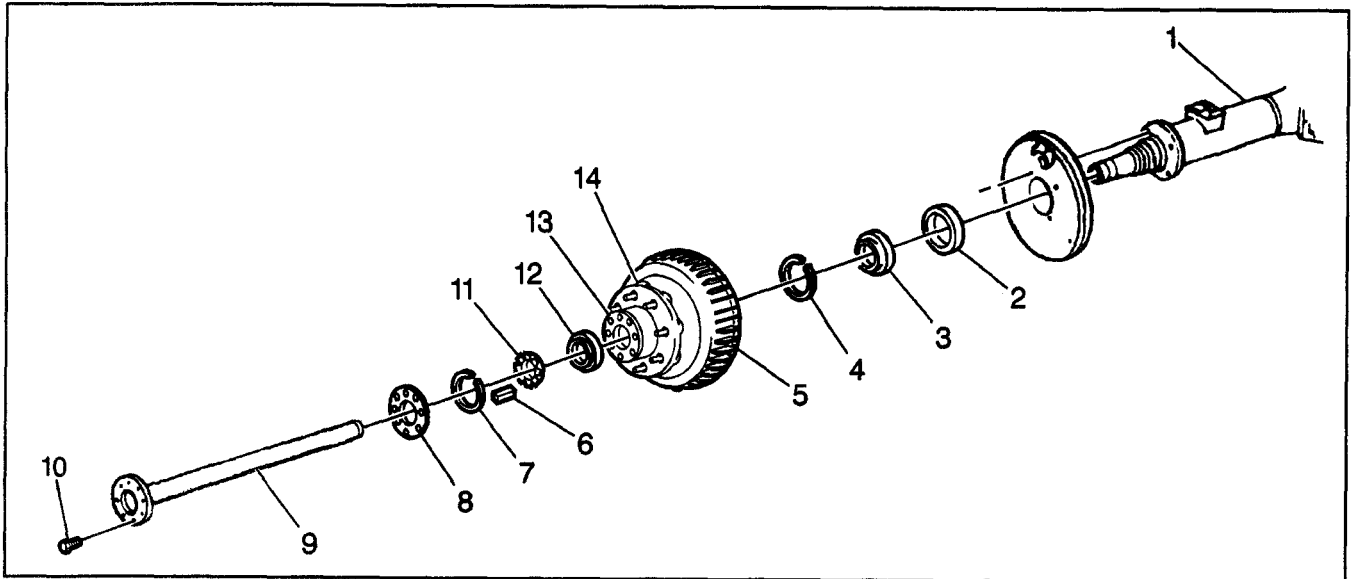

177310

Legend

- |                                     |                                  |
|-------------------------------------|----------------------------------|
| (1) Axle Tube                       | (8) Rear Axle Gasket             |
| (2) Oil Seal                        | (9) Rear Axle Shaft              |
| (3) Rear Wheel Inner Bearing        | (10) Rear Axle Shaft Bolt        |
| (4) Retainer Ring                   | (11) Wheel Bearing Adjusting Nut |
| (5) Rear Brake Drum                 | (12) Rear Wheel Outer Bearing    |
| (6) Wheel Bearing Adjusting Nut Key | (13) Rear Wheel Stud             |
| (7) Retaining Spring                | (14) Rear Wheel Hub              |



## Diagnostic Information and Procedures

### Noise Diagnosis (Axle)

#### Rear Axle Noise

The proper diagnosis is an important part of rear axle repair. In axle work, one of the most difficult conditions to diagnose is noise. Locating a broken axle shaft or broken differential gear presents little or no problem, but locating and isolating axle noise can be an entirely different matter.

Any gear driven unit, especially an automotive drive axle where the engine torque multiplication occurs at a 90 degree turn in the driveline, produces a certain amount of noise. Therefore, an interpretation must be made for each vehicle in order to determine where the noise is normal or if a problem actually exists. A certain amount of noise must be expected and cannot be eliminated by conventional repairs or adjustment.

Normal axle noise can be described as a slight noise heard only at a certain speed or under unusual or remote conditions. For example, the noise tends to reach a peak at speeds from 60 to 100 km/h (40 to 60 mph) depending on road and load conditions, or on gear ratio and tire size. This slight noise is in no way indicative of trouble in the axle assembly.

Driveline noises may confuse even the best technician. Vehicle noises coming from tires, transmission, propeller shaft, universal joints, and front or rear wheel bearings are often mistaken for axle noise. Such practices as raising tire pressure in order to eliminate tire noise (although this will not silence tread noise of mud and snow tires), or listening for the noise at varying speeds and road surfaces (drive, float, and coast conditions), will aid in locating the source of alleged axle noises. Isolate the noise to a specific driveline component.

#### External Noise

Noise which seems to be coming from the rear axle may actually be produced somewhere else. Determine whether the noise might originate in the tires, the road surface, the front wheel bearings, the engine, or the transmission.

#### Road Noise

Driving on certain road surfaces, such as brick or rough-surfaced concrete, causes noise which may be mistaken for tire or rear axle noise. Driving on a different type of road, such as smooth asphalt or dirt, will quickly show whether the road surface is the cause of noise. Road noise usually is the same in drive as in coast.

#### Tire Noise

Tire noise can easily be mistaken for rear axle noise, even though noisy tires may be located on the front wheels. Tires worn unevenly, or having surfaces on non-skid divisions worn in sawtooth fashion, are usually noisy and may produce vibrations which seem to originate elsewhere in the vehicle. This is particularly true with low tire pressure.

#### Tire Noise Test

Tire noise changes with different road surfaces, but rear axle noise does not. Temporarily inflating tires to 345 kPa (50 psi) pressure, for test purposes only, will materially alter noise caused by tires but will not affect noise caused by the rear axle. Rear axle noise usually stops when coasting at speeds under 30 mph; however, tire noise continues with a lower tone as the vehicle speed is reduced. Rear axle noise usually changes when the tire pulls in a forward direction or when the vehicle coasts down the road and tire noise remains about the same.

#### Engine and Transmission Noises

Sometimes a noise which seems to originate in the rear axle is actually caused by the engine or the transmission. In order to determine which unit is actually causing the noise, observe the approximate vehicle speeds and conditions under which the noise is the most pronounced; then stop the vehicle in a quiet place to avoid interfering noises. With the transmission in neutral, run the engine slowly up and down through the engine speeds corresponding to the vehicle speed at which the noise was most pronounced. If a similar noise is produced with the vehicle standing, the noise is caused by the engine or transmission and not the rear axle.

#### Front Wheel Bearing Noise

Loose or rough front wheel bearings will cause noise that may be confused with rear axle noise; however, front wheel bearing noise does not change when comparing pull and coast conditions. Light application of the brake, while holding the vehicle speed steady, will often cause the wheel bearing noise to diminish, since this takes some weight off the bearing. Front wheel bearings may be easily checked for noise by jacking up the wheels and spinning them, and also by shaking the wheels in order to determine if the bearings are excessively loose.

#### Body Boom Noise or Vibration

Objectionable body boom noise or vibration at 55–65 mph (90–100 km/h) can be caused by an unbalanced propeller shaft. Excessive looseness at the spline can contribute to this unbalance.

Other items that may also contribute to the noise problem are as follows:

- Undercoating or mud on the shaft, causing unbalance
- Shaft or companion flange balance weights missing
- Shaft damage, such as bends, dents, or nicks
- Rough tires (Switch tires from a known good vehicle in order to determine a tire fault.)

If, after making a comprehensive check of the vehicle, all indications point to the rear axle, further diagnostic steps are necessary in order to determine the axle components at fault. True rear axle noise generally falls into two categories: gear noise and bearing noise.

### Rear Axle Noise

If a careful test of the vehicle shows that the noise is not caused by external items, assume that noise is caused by the rear axle assembly. Test the rear axle on a smooth level road in order to avoid road noise. Do not test the rear axle for noise by running with the rear wheels jacked up.

Noise in the rear axle assembly may be caused by a faulty propeller shaft, faulty wheel bearings, faulty differential or pinion shaft bearings, misalignment between two U-joints, or worn differential side gears and pinions. Noise may be caused by a mismatched, improperly adjusted, or scored ring and pinion gear set.

### Rear Wheel Bearing Noise

A rough rear wheel produces a vibration or growl which continues with the vehicle coasting and the transmission in neutral. A brinelled rear wheel bearing causes a knock or click, approximately every two revolutions of the rear wheel, since the bearing rollers do not travel at the same speed as the rear axle and wheel. With the rear wheels jacked up, spin the rear wheels by hand while listening at the hubs for evidence of a rough or brinelled wheel bearing.

### Differential Side Gear and Pinion Noise

Differential side gears and pinions seldom cause noise since the movement is relatively slight on straight ahead driving. Noise produced by these gears will be most pronounced on turns.

Pinion bearing failures can be determined by how the bearings rotate at higher speeds as opposed to differential side bearings and axle shaft bearings. Rough or brinelled pinion bearings produce a continuous low-pitched whirring or scraping noise starting at a low speed.

Side bearings produce a constant rough noise pitched lower than pinion bearing noise. Side bearing noise may also fluctuate in the previous rear wheel bearing test.

### Gear Noise

There are two basic types of gear noise.

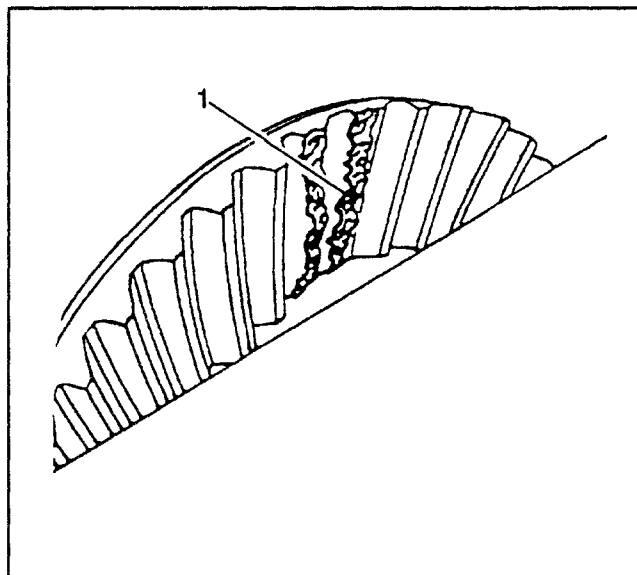

156406

The first type is produced by broken, bent, or forcibly damaged gear teeth (1) and is usually quite audible over the entire speed range and presents no particular problem in diagnosis. For example, hypoid gear tooth scoring generally results from the following: insufficient lubricant, improper break-in, incorrect lubricant, insufficient gear backlash, improper ring and pinion gear alignment, or loss of drive pinion nut torque. The scoring will progressively lead to complete erosion of the gear tooth, or gear tooth pitting and eventual fracture if the initial scoring condition is not corrected.

Other causes of hypoid tooth fracture are extended overloading of the gear set which will produce fatigue fracture, or shock loading which will result in sudden malfunction.

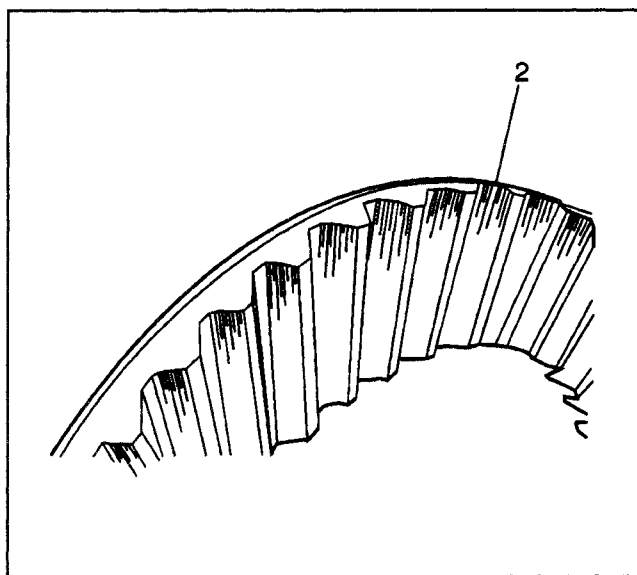

156776

Differential pinion and side gears rarely give trouble. Common causes of differential malfunction are shock loading, and seizure of the differential pinions to

the cross shaft resulting from excessive wheel spin and consequent lubrication breakdown (2). The second type of gear noise pertains to the mesh pattern of the gear teeth. This form of abnormal gear noise can be recognized because it produces a cycling pitch (whine) and will be very pronounced in the speed range at which it occurs, appearing under either drive, float or coast conditions. Drive is acceleration or heavy pullout. Coast is allowing the vehicle to roll down the road without accelerating and float is lightly stepping on the accelerator pedal in order to keep the vehicle from driving the engine; the vehicle slows down gradually but the engine still pulls slightly. Gear noise tends to peak in a narrow speed range or ranges and will tend to remain constant in pitch. Bearing noise will vary in pitch with vehicle speeds.

Refer to *Noise Diagnosis (Wheel Bearing)* for bearing diagnoses.

### Noise Diagnosis (Wheel Bearing)

#### Tapered Roller Bearing Diagnosis

Consider the following factors when diagnosing bearing condition:

1. General condition of all parts during disassembly and inspection.
2. Classify the failure with the aid of the illustrations.
3. Determine the cause.
4. Make all repairs following recommended procedures.

#### Abrasive Roller Wear

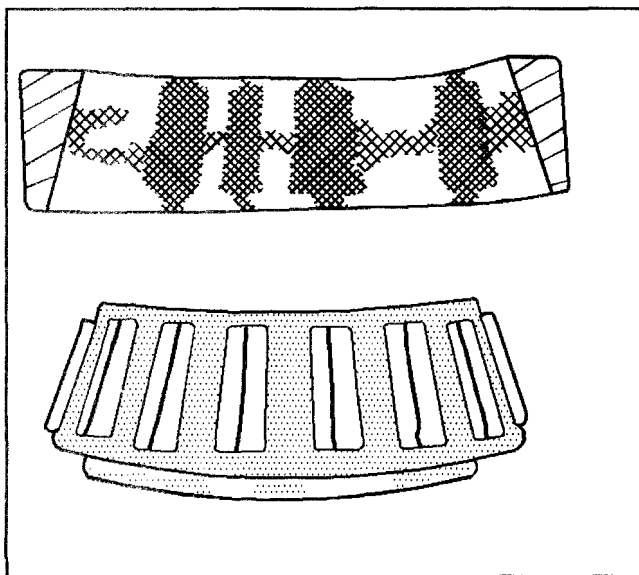

1452

Pattern on the races and the rollers caused by fine abrasives. Clean all of the parts and the housings. Check the seals and the bearings. Replace any leaky, rough, or noisy bearings.

#### Abrasive Step Wear

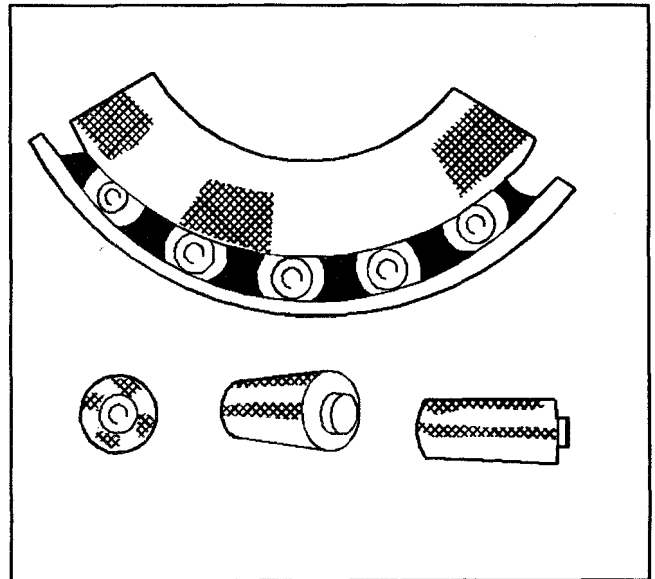

1453

Pattern on the roller ends caused by fine abrasives. Clean all of the parts and the housings. Check the seals and the bearings. Replace any leaky, rough, or noisy bearings.

#### Galling

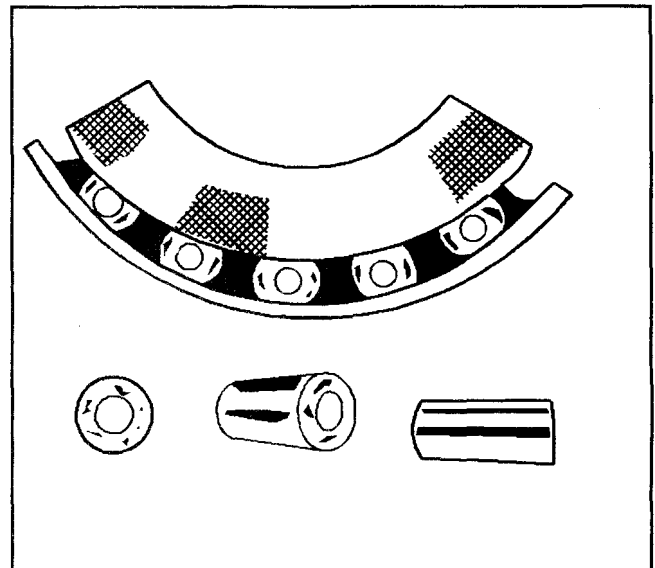

1454

Metal smears on the roller ends due to overheating, lubricant failure, or lubricant overload. Replace the bearing. Check the seals. Check for proper lubrication.

**Etching**

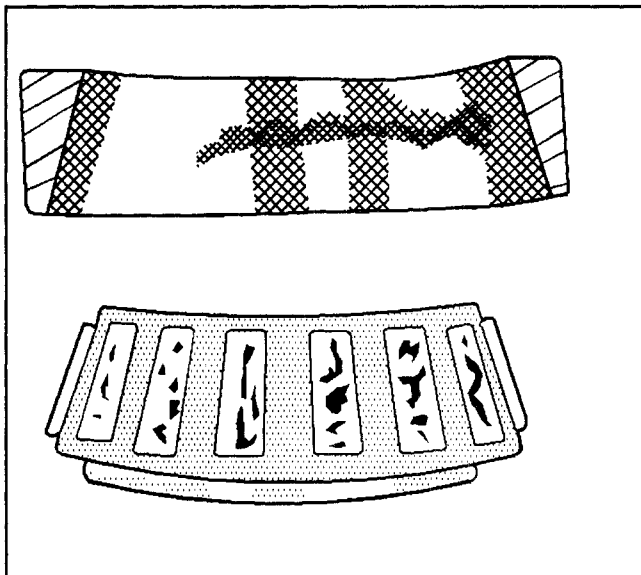

1455

Bearing surfaces appear gray or grayish black in color, with related etching away of material usually at roller spacing. Replace the bearings. Check the seals. Check for proper lubrication.

**Bent Cage**

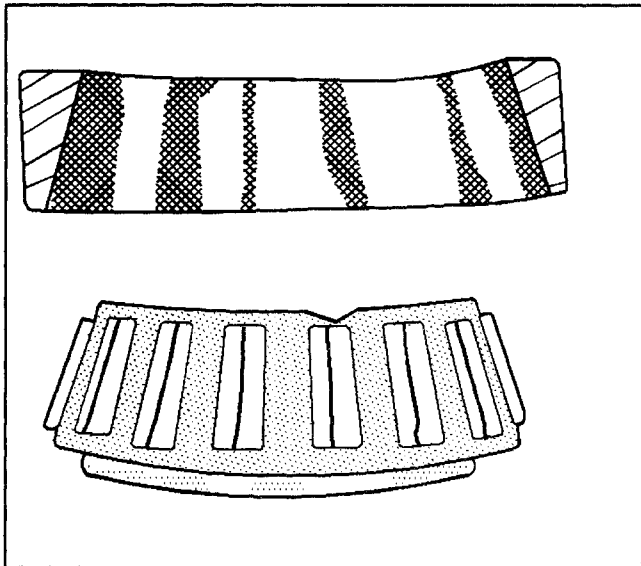

1456

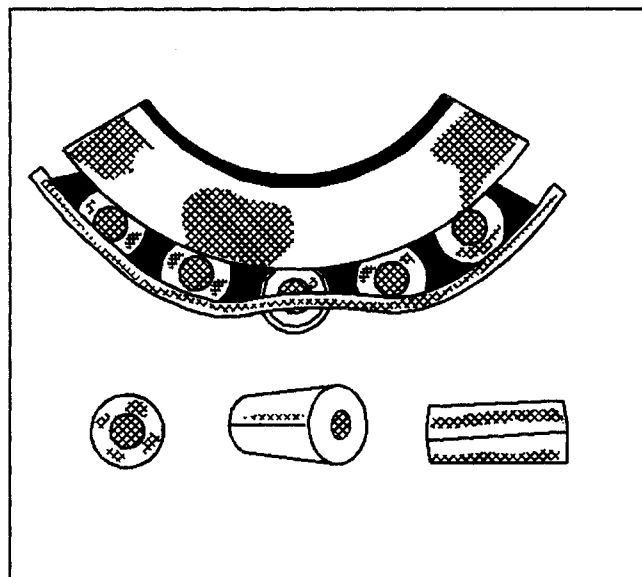

1648

Damaged cage due to improper handling or improper tool usage. Replace the bearing.

**Cage Wear**

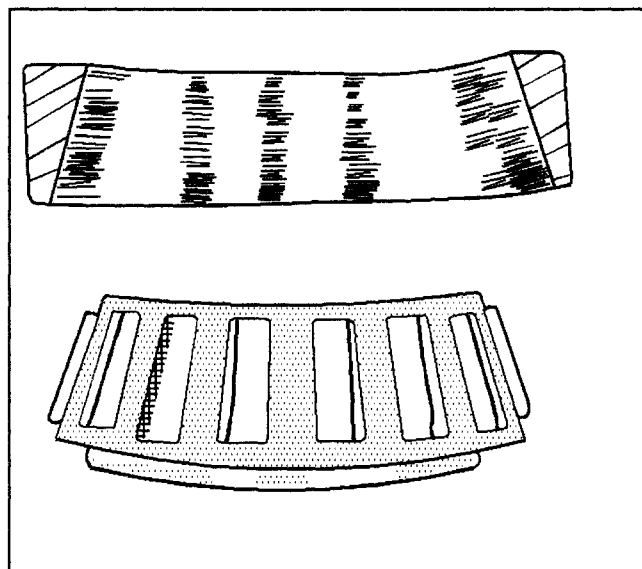

1457

Wear around the outside diameter of the cage and the roller pockets caused by abrasive material. Wear caused from inefficient lubrication. Clean the related parts and the housings. Check the seals. Replace the bearings.

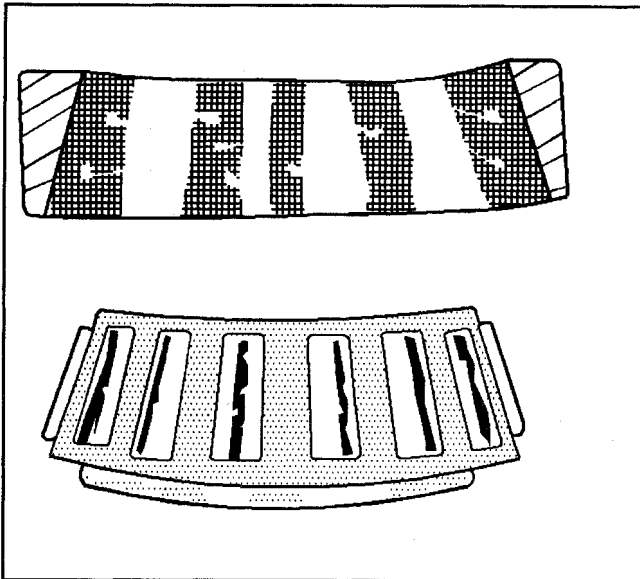
**Indentations**

1458

Surface depressions on the race and the rollers caused by hard particles of foreign matter. Clean all the parts and the housings. Check the seals. Replace rough or noisy bearings.

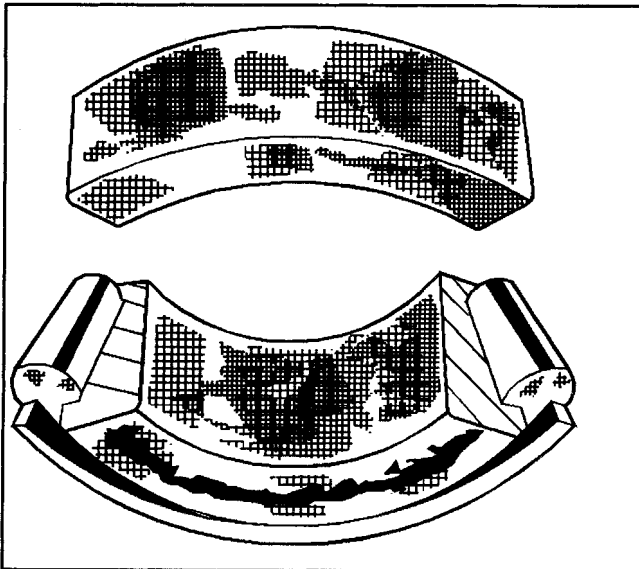
**Fretting**

1459

Corrosion caused by small relative movement of parts with no lubrication. Replace the bearing. Clean the related parts. Check the seals. Check for proper lubrication.

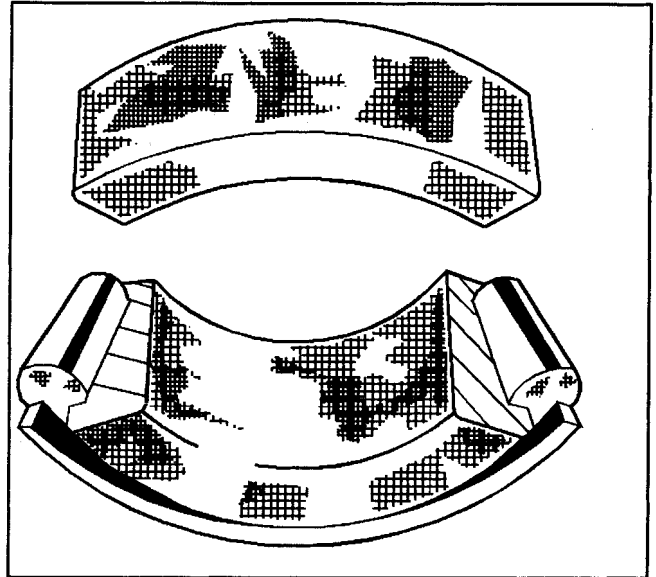
**Smears**

1460

Smearing of the metal due to slippage. Slippage can be caused by the following factors:

- Poor fits
- Lubrication
- Overheating
- Overloads
- Handling damage

Replace the bearings. Clean the related parts. Check for proper fit and lubrication.

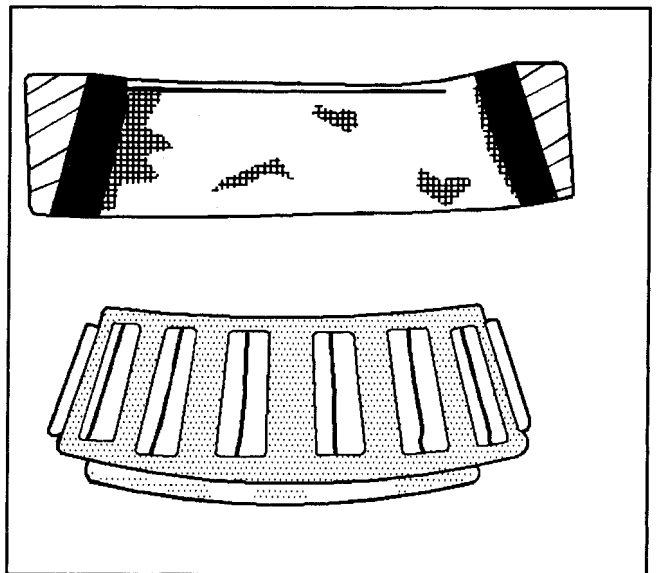
**Stain Discoloration**

1461

Discoloration ranging from light brown to black. This discoloration is caused from incorrect lubrication or moisture. Reuse the bearing if you can remove the stains with light polishing. Reuse the bearing if there is no evidence of overheating. Check the seals and the related parts for damage.

**Heat Discoloration**

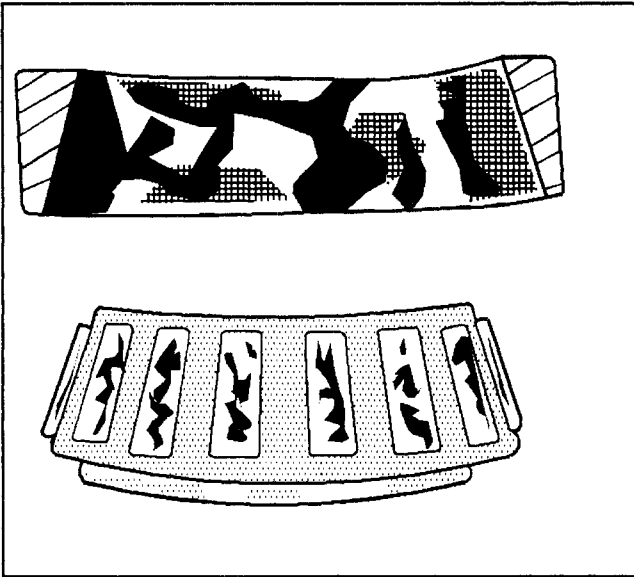

1462

Heat discoloration ranges from faint yellow to dark blue. This discoloration results from overload or an incorrect lubricant. Excessive heat causes softening of the races or the rollers. In order to check for loss of temper on the races and the rollers, perform a file test. A file drawn over a tempered part will grab and cut the metal. A file drawn over a hard part will glide readily with no metal cutting. Replace the bearings if overheating damage is indicated. The tempered part will fail the file test. Check the seals and the other related parts.

**Misalignment**

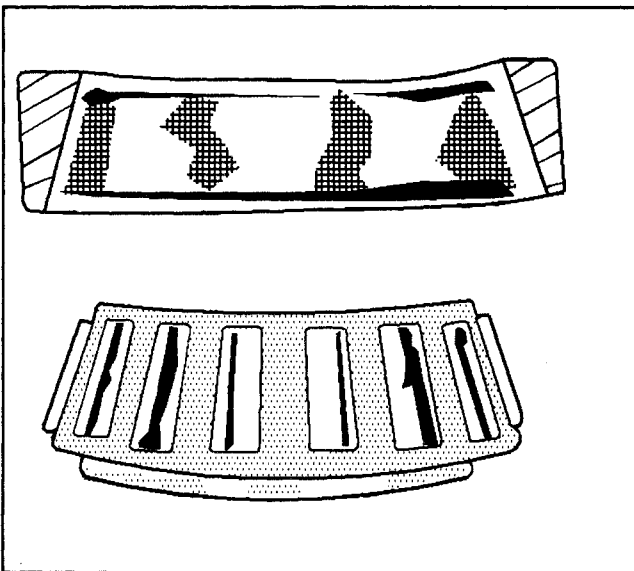

1463

A misaligned outer race due to a foreign object. Clean the related parts. Replace the bearing. Ensure the races are properly sealed.

**Cracked Inner Race**

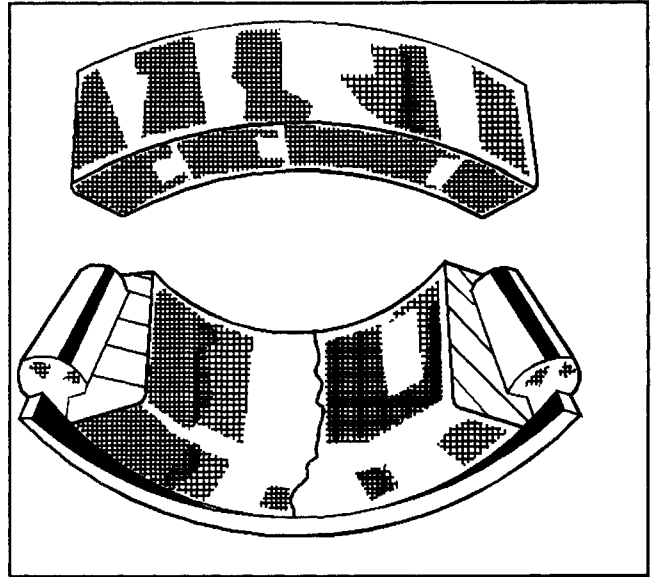

1464

Cracked race due to improper fit, cocking, or poor bearing seats. Replace the bearing. Correct bearing seats.

**Fatigue Spalling**

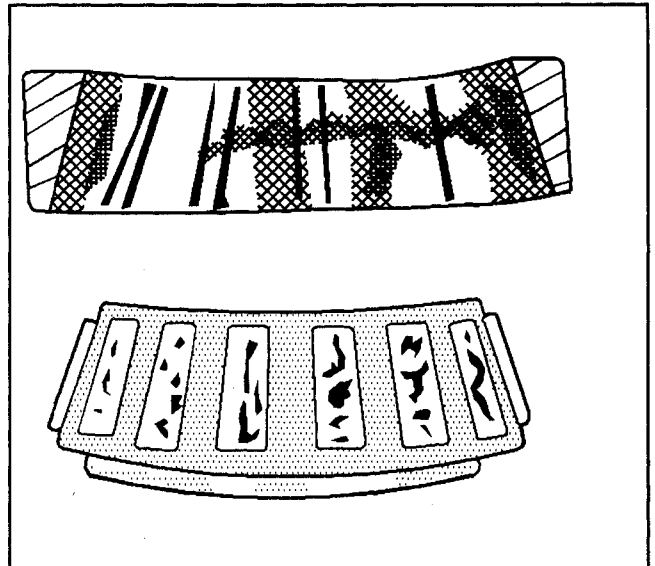

1465

Flaked surface metal that results from fatigue. Replace the bearing. Clean all related parts.

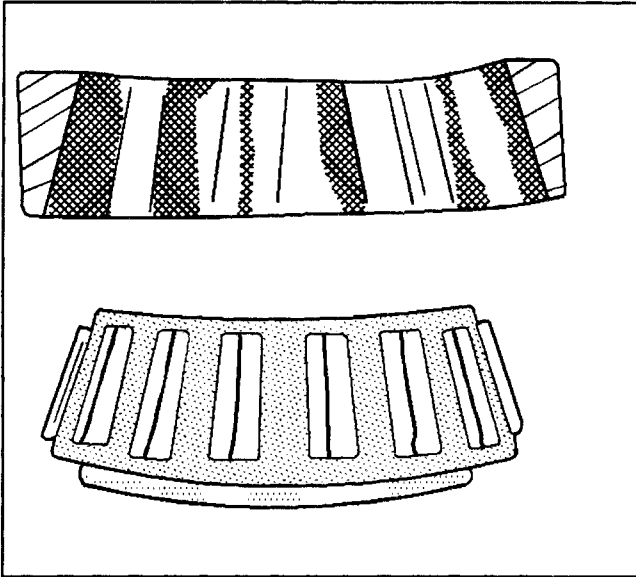
**Brinelling**

1466

Surface indentations in the race way caused by the rollers under impact loading or caused from vibration while the bearing is not rotating. Replace a rough or noisy bearing.

## Repair Instructions

### Axle Shaft Replacement (All Models)

#### Removal Procedure

1. Remove the axle shaft bolts (6).
2. Lightly tap the axle shaft flange with a soft-faced hammer in order to loosen the gasket (4).
3. Grip the rib on the axle shaft with locking pliers and twist in order to start the axle shaft (5) removal.
4. Remove the axle shaft (5) from the tube.
5. Clean the axle shaft.
6. Remove the gasket (4) and the RTV.
7. Clean the outside face of the hub assembly (3).
8. Inspect all the parts and replace as necessary.

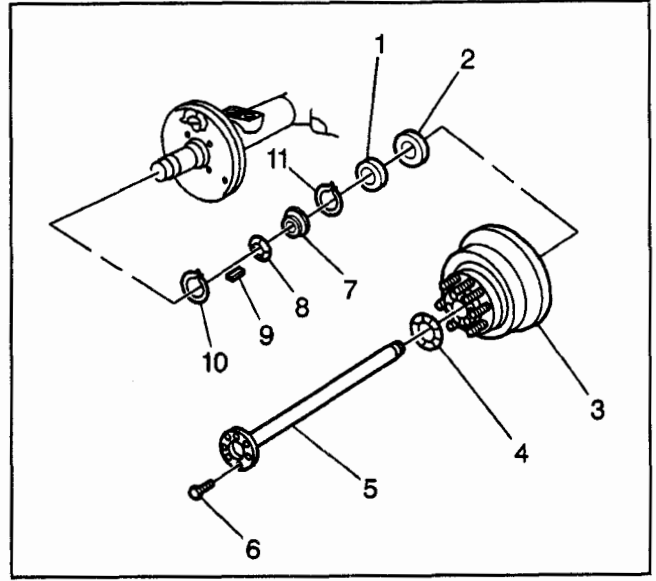

160066

#### Installation Procedure

1. Install the axle shaft (5) with a gasket (4) or RTV applied.
  - Be sure the shaft splines mesh into the differential side gear.
  - Align the holes in the axle shaft flange with the holes in the hub (3).

**Notice:** Refer to *Fastener Notice* in Cautions and Notices.

2. Install the bolts (6).

#### Tighten

Tighten the bolts (6) to 156 N·m (115 lb ft).

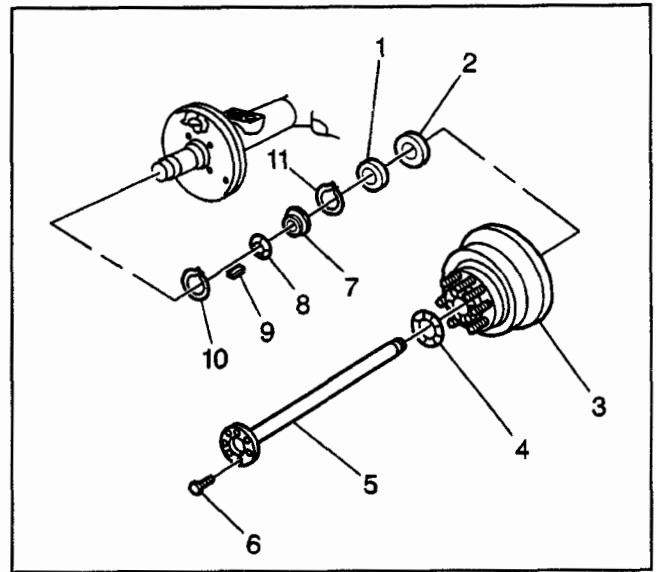

160066



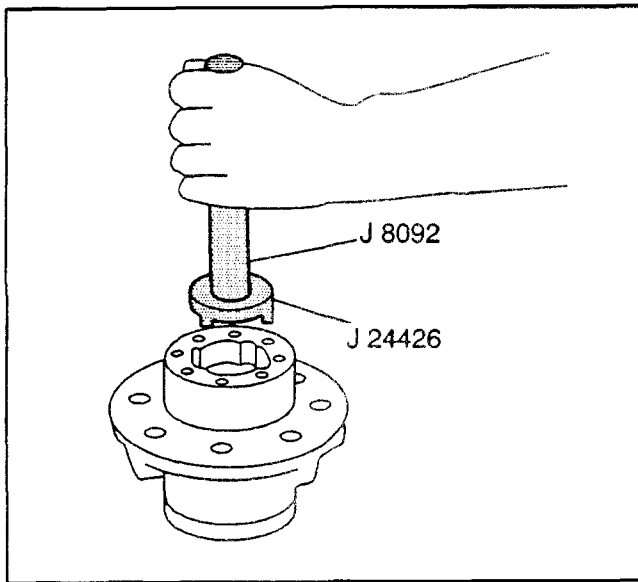

156462

## Oil Seal and/or Bearing Replacement (Disc)

### Removal Procedure

#### Tools Required

- J 8092 Drive Handle
- J 8608 Outer Pinion Bearing Cup Installer
- J 24426 Outer Wheel Bearing Cup Installer
- J 24427 Inner Wheel Cup Bearing Installer
- J 39114-A Axle Shaft Seal Installer

1. Raise the vehicle until the wheels are free to rotate.
2. Remove the axle shaft. Refer to *Axle Shaft Replacement (All Models)*.
3. Remove the hub and rotor assembly. Refer to or *Hub and Rotor Assembly Replacement*.
4. Remove the inner bearing and the oil seal.
  - Lay the drum on a flat surface using a shop towel in order to catch the bearing and the seal.
  - Use a drift to remove the bearing cup and the seal.
5. Remove the retaining ring using snap ring pliers.
6. Remove the outer bearing using the J 8092 with the J 24426.
7. Drive the bearing and the cup from the hub.
8. Clean the old sealing compound from the oil seal bore in the hub.
9. Clean the bearing assemblies in a solvent using a stiff brush to remove the old lubricant.
10. Dry the bearings with compressed air. Do not spin the bearings.
11. Clean the lubricant from the axle tube and from inside the hub.
12. Clean the gasket material, if used, from the hub and the axle shaft.
13. Inspect the bearings for any wear, chipped edges or other damage. Refer to *Noise Diagnosis (Wheel Bearing)*.
14. Check for any flat or rough spots on the rollers.
15. Check the cups for any pits or cracks.
16. Replace and discard the old oil seal.
17. Pack the inner and the outer bearing with wheel bearing lubricant P/N 1051344. Refer to *Lubrication Specifications*.

**Installation Procedure**

1. Install the outer bearing cup into the hub.

**Important:** Install the *J 8608* upside down on the *J 8092* so that the chamfer does not contact the bearing cup.

2. Drive the outer bearing cup into the hub using the *J 8608* and the *J 8092*. Drive the cup beyond the retaining ring groove.
3. Install the retaining ring into the groove.

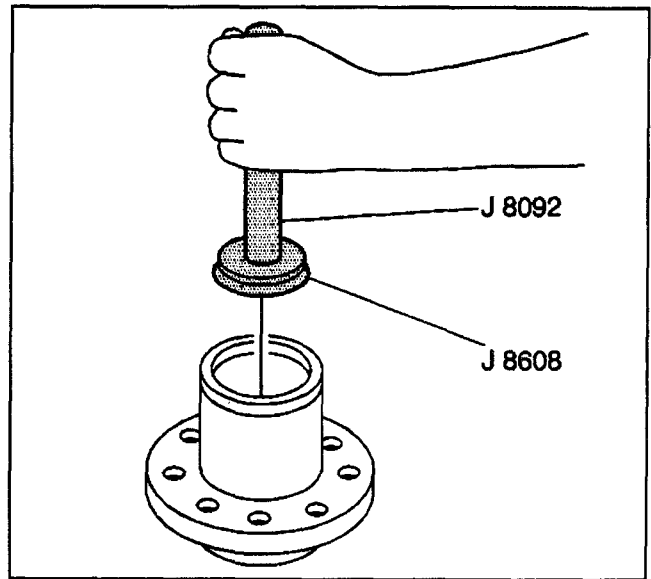

33875

4. Drive the cup back onto the retaining ring using the *J 24426* with the *J 8092*.

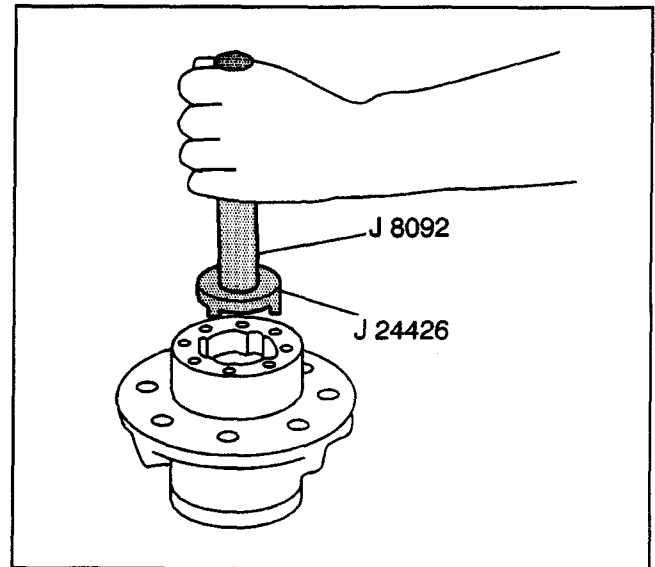

156462

5. Install the inner bearing cup using the *J 24426* and the *J 8092* until the cup is seated against the hub shoulder.
6. Install the inner bearing.
7. Install the outer bearing.

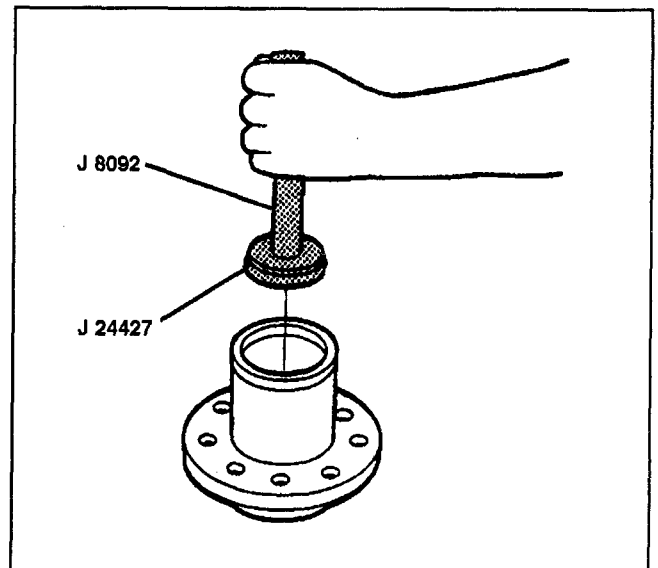

33870

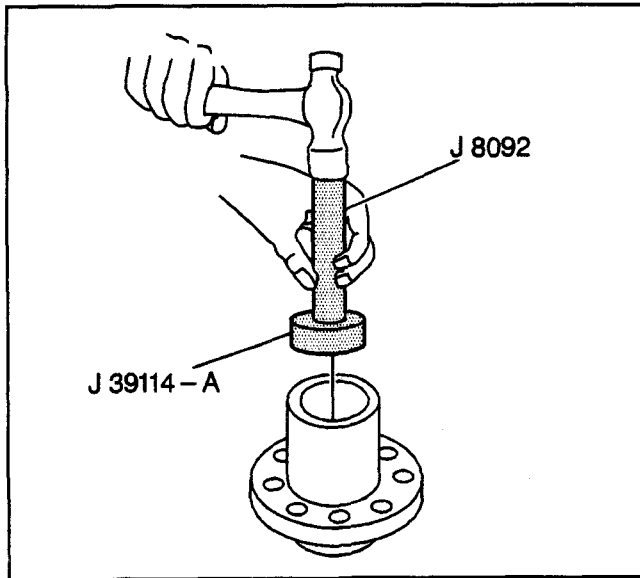

156477

8. Install the new oil seal using the *J 8092* and the *J 39114-A*.
9. Install the hub and drum or the hub and rotor. Refer to *Hub and Rotor Assembly Replacement*.
10. Install the outer bearing.
11. Adjust the bearing preload. Refer to *Wheel Bearing Adjustment (Disc Brakes)*.
12. Install the axle shaft. Refer to *Axle Shaft Replacement (All Models)*.
13. Lower the vehicle.

### Oil Seal and/or Bearing Replacement (Drum)

#### Removal Procedure

#### Tools Required

- *J 8092* Drive Handle
- *J 8608* Outer Pinion Bearing Cup Installer
- *J 24426* Outer Wheel Bearing Cup Installer
- *J 24427* Inner Wheel Cup Bearing Installer
- *J 39114-A* Axle Shaft Seal Installer

1. Raise the vehicle until the wheels are free to rotate.
2. Remove the axle shaft (5). Refer to *Axle Shaft Replacement (All Models)*.
3. Remove the hub and drum. Refer to *Hub and Drum Assembly Replacement (All Models)*.
4. Remove the oil seal (2).
5. Use a drift to remove the inner bearing and the cup (1).
6. Use snap ring pliers to remove the retaining ring (11).

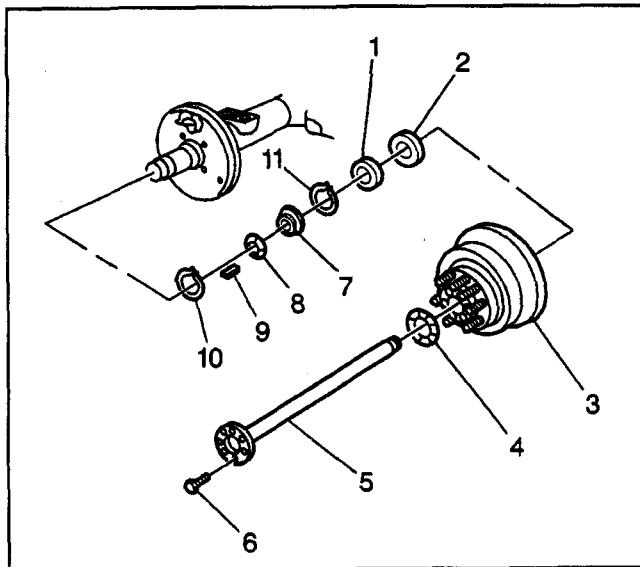

160066

7. Remove the outer bearing ring using *J 24426* and *J 8092*.

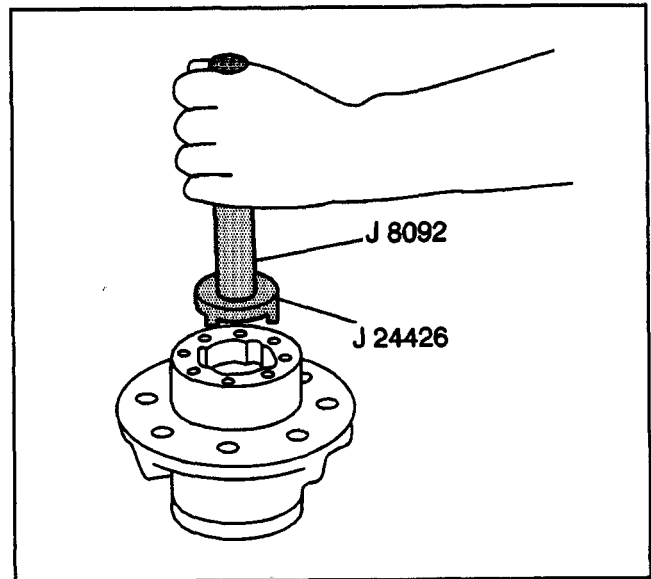

156462

8. Drive the bearing and the cup (14) from the hub (3).
9. Clean the old oil sealing compound from the oil seal bore in the hub.
10. Clean the bearing assemblies in a solvent using a stiff brush in order to remove the old lubricant.
  - Dry the bearings with compressed air.
  - Do not spin the bearings.
11. Clean the lubricant from the axle housing and from the inside of the hub.
12. Remove the gasket material from the hub and the axle shaft.
13. Inspect the bearings for wear, chipped edges or other damage.
14. Check for flat or rough spots on the rollers.
15. Inspect the cups for pits and cracks.
16. Replace parts as necessary.

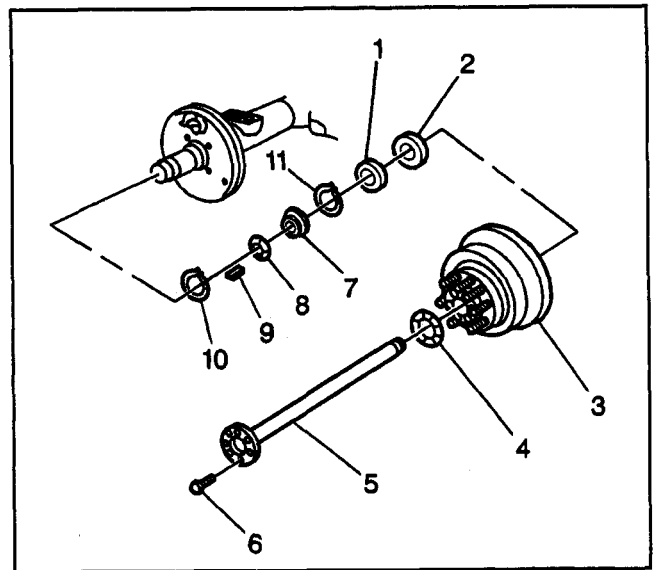

160066

**Installation Procedure**

1. Install the outer bearing cup (7) into the hub (3).

**Important:** Install the *J 8608* upside down on the *J 8092* so that the chamber does not contact the bearing cup.

2. Drive the outer bearing cup (7) into the hub (3) using the *J 8608* and the *J 8092*.
3. Drive the outer bearing cup (7) beyond the retaining ring groove.
4. Install the retaining ring (11) in the groove.

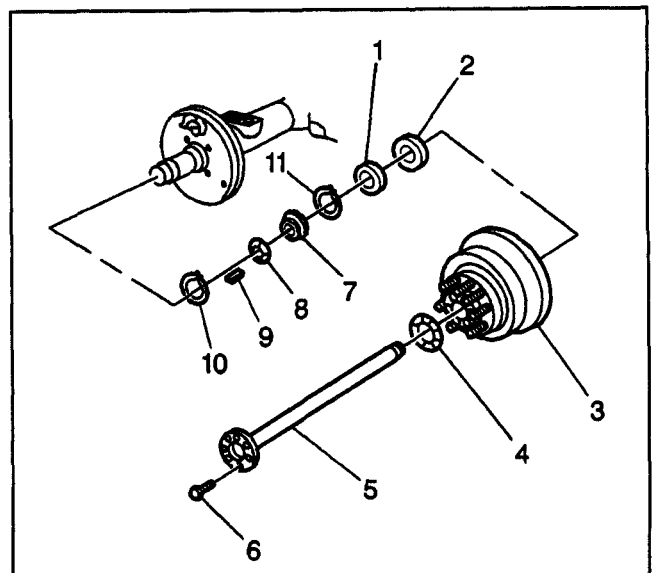

160066

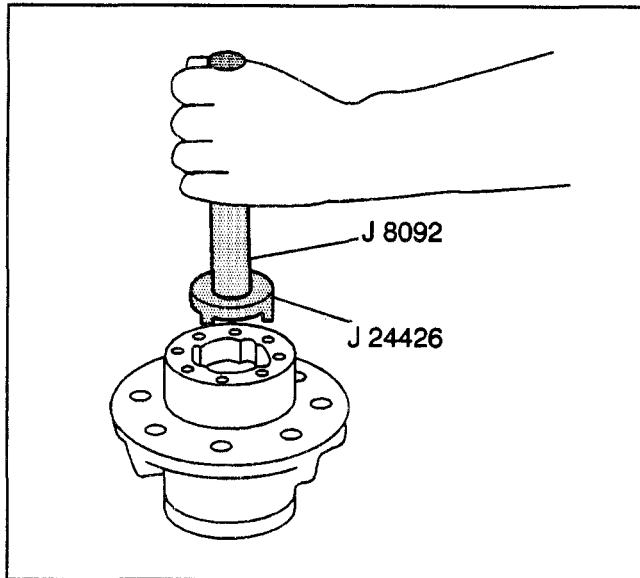

156462

5. Drive the outer bearing cup (7) onto the retaining ring (11) using the *J 24426*.
6. Install the inner bearing cup using the *J 24427* and the *J 8092*.

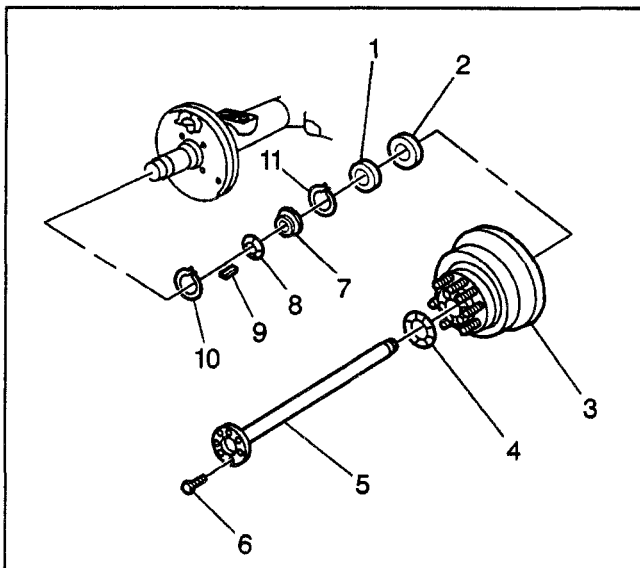

160066

7. Drive the inner bearing cup (1) until it is seated against the hub shoulder.
8. Install the inner bearing.
9. Install a new oil seal (2) using the *J 39114-A*.
10. Install the hub and drum assembly (3). Refer to *Hub and Drum Assembly Replacement (All Models)*.
11. Install the wheel bearing adjusting nut (8).
12. Adjust the bearing preload. Refer to *Wheel Bearing Adjustment (Drum Brakes)*.
13. Install the axle shaft (5). Refer to *Axle Shaft Replacement (All Models)*.
14. Lower the vehicle.

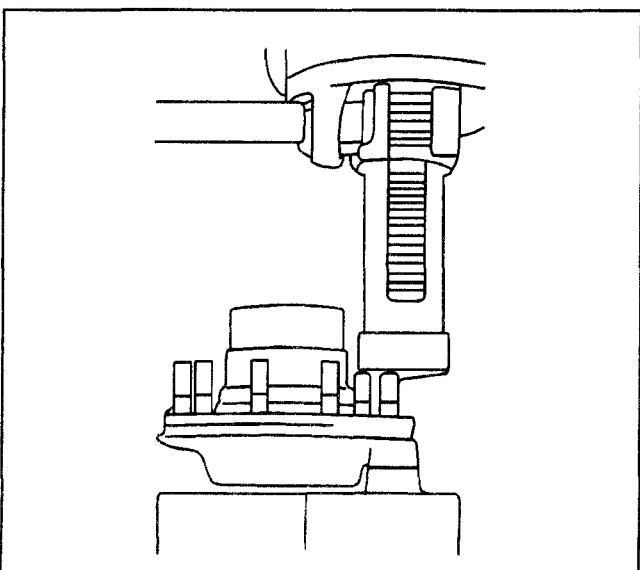

156480

### Wheel Stud Replacement

Wheel studs are serrated and may also be swaged in place; however, the replacement procedure remains the same for both types of installation.

1. Press the wheel studs out of the hub flange.

2. Press the new wheel studs into place.
  - Make sure of a tight fit.
  - When replacing all of the wheel bolts, make sure that the hub oil deflector (if equipped) is in position under the wheel bolt heads.

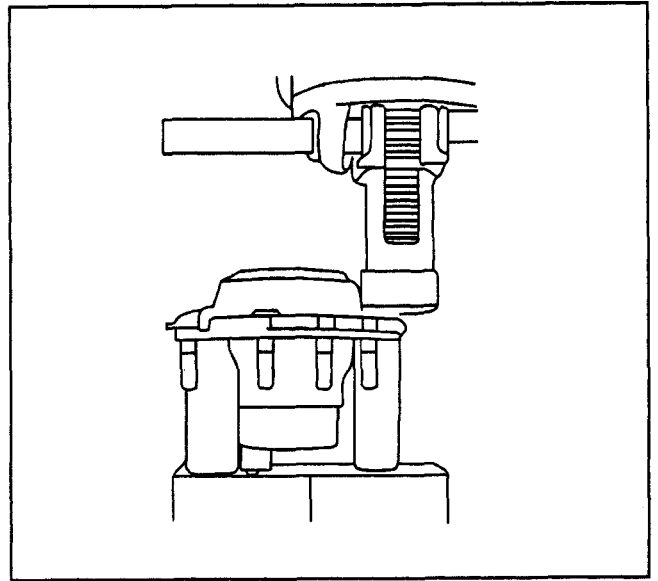

156483

## Pinion Oil Seal Replacement (10 1/2 Ring Gear)

### Removal Procedure

#### Tools Required

- J 8614-01 Pinion Flange Holder/Remover
- J 24384 Pinion Oil Seal Installer

The pinion oil seal and the pinion flange may be replaced with the carrier assembly installed in the vehicle.

1. Raise the vehicle.
2. Disconnect the propeller shaft. Refer to *Propeller Shaft Replacement (One-Piece)* or *Two-Piece Propeller Shaft Replacement* or *Three-Piece Propeller Shaft Replacement*.
3. Make an alignment mark (1) on the pinion stem, pinion nut and pinion flange (2) for use as an installation guide.

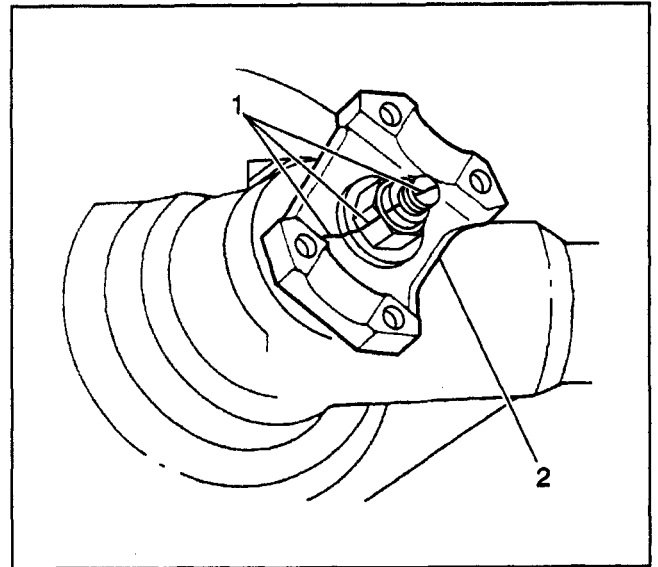

156435

4. Remove the pinion nut using J 8614-01.

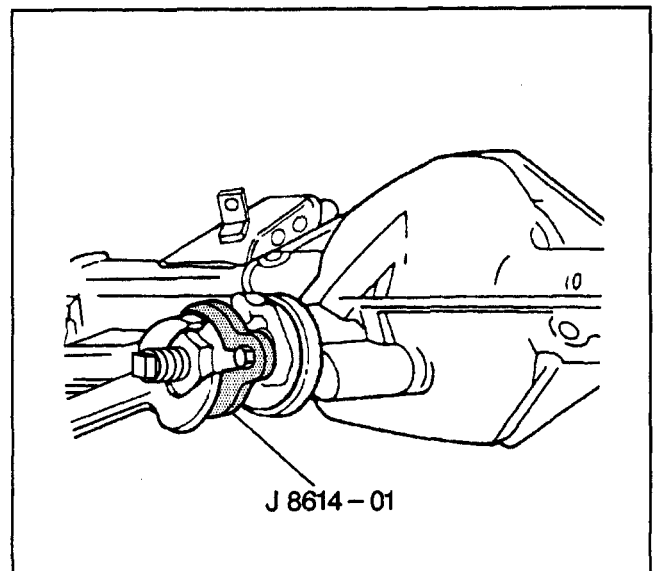

156437

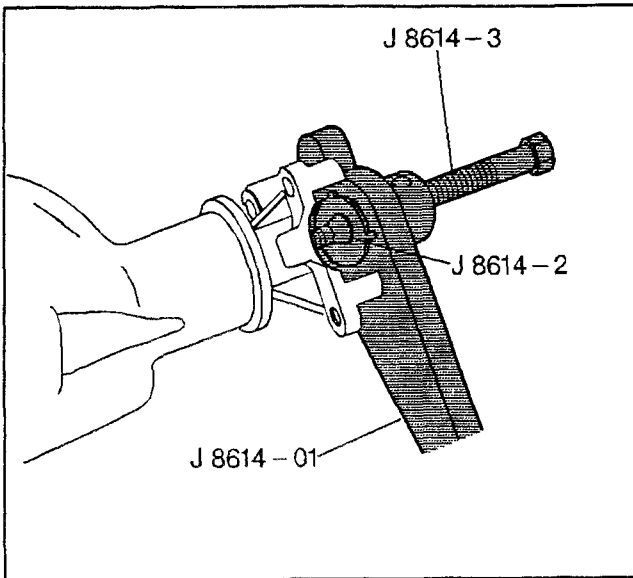

1494

5. Remove the flange using *J 8614-01* with the special nut and forcing screw.
6. Pry the oil seal from the bore.
  - Do not damage the machined surfaces
  - Clean any foreign material from the contact area
7. Inspect the following
  - The oil seal mating surfaces for any burrs which may cause seal failure
  - Flange deflector for any abnormality such as cracking or distortion
8. Replace parts as necessary.

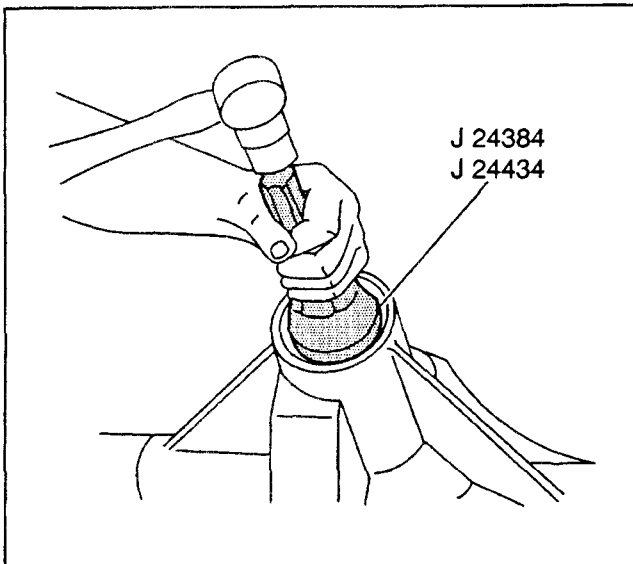

156490

### Installation Procedure

1. Lubricate the inside diameter of the new oil seal with extreme pressure lubricant such as P/N 9985038.
2. Install the oil seal into the bore using the *J 24384*.

**Important:** Do not coat the bearing.

3. Pack the cavity between the pinion stem, pinion flange and pinion nut with a non-hardening sealer such as Permatex® Type A or the equivalent.

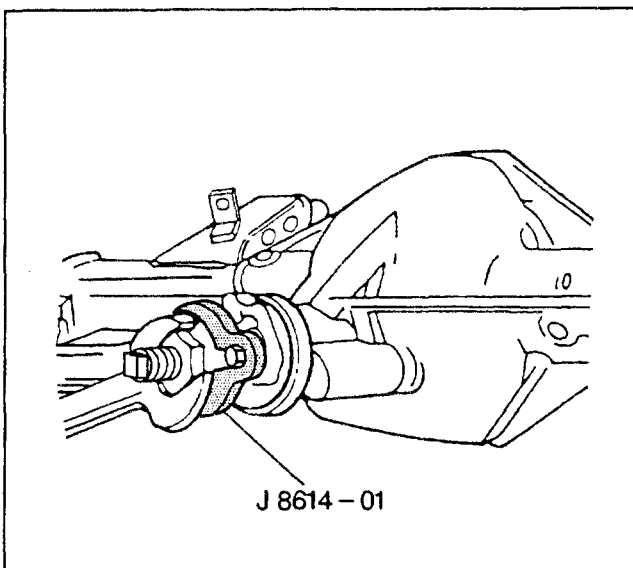

156437

4. Install the pinion flange using the *J 8614-01* and use the alignment marks as a guide.

**Notice:** Refer to *Fastener Notice* in Cautions and Notices.

5. Install the pinion nut using the *J 8614-01* and use the alignment marks as a guide.

### Tighten

- 5.1. Tighten the nut to the same position marked in the removal procedure.
- 5.2. Tighten the pinion nut 1/16 inch beyond the alignment mark.
6. Install the propeller shaft. Refer to *Propeller Shaft Replacement (One-Piece)* or *Two-Piece Propeller Shaft Replacement* or *Three-Piece Propeller Shaft Replacement*.

## Pinion Oil Seal Replacement (11 Inch Ring Gear )

### Removal Procedure

#### Tools Required

- J 8614-01 Pinion Flange Holder/Remover
- J 24384 Pinion Oil Seal Installer

The pinion oil seal and the pinion flange may be replaced with the carrier assembly installed in the vehicle.

1. Raise the vehicle.
2. Disconnect the propeller shaft. Refer to *Propeller Shaft Replacement (One-Piece)* or *Two-Piece Propeller Shaft Replacement* or *Three-Piece Propeller Shaft Replacement*.
3. Make an alignment mark (1) on the pinion stem, pinion nut and pinion flange (2) for use as an installation guide.
4. Remove the pinion nut using J 8614-01.

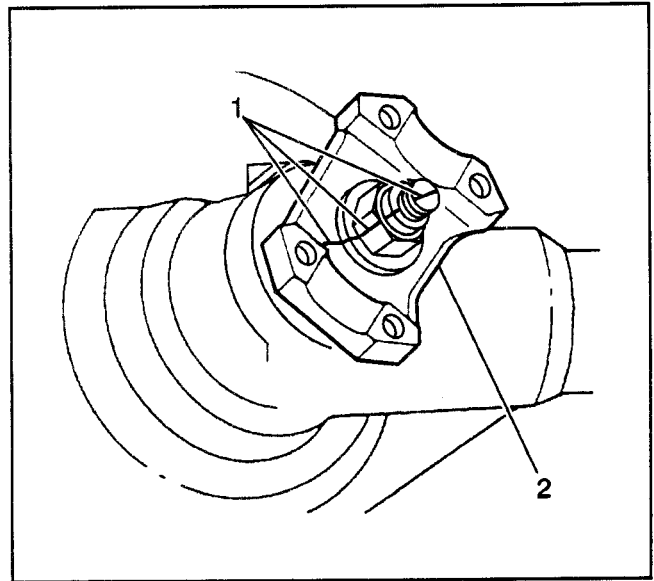

156435

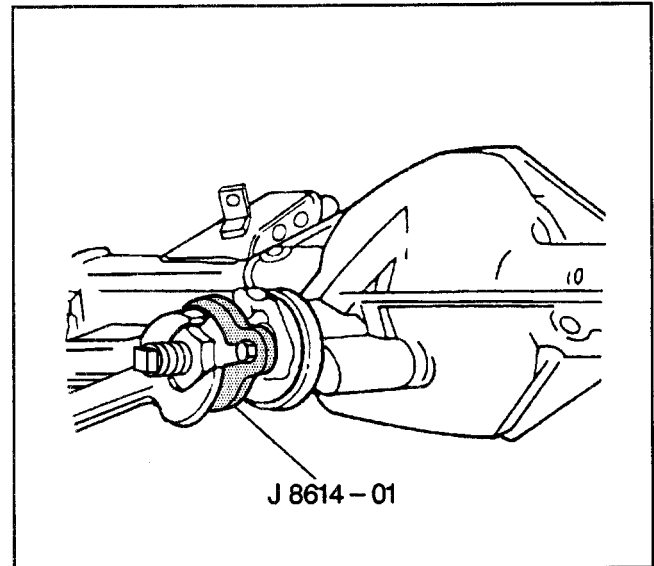

156437

5. Remove the flange using J 8614-01 with the special nut and forcing screw.
6. Pry the oil seal from the bore.
  - Do not damage the machined surfaces
  - Clean any foreign material from the contact area
7. Inspect the following
  - The oil seal mating surfaces for any burrs which may cause seal failure
  - Flange deflector for any abnormality such as cracking or distortion
8. Replace parts as necessary.

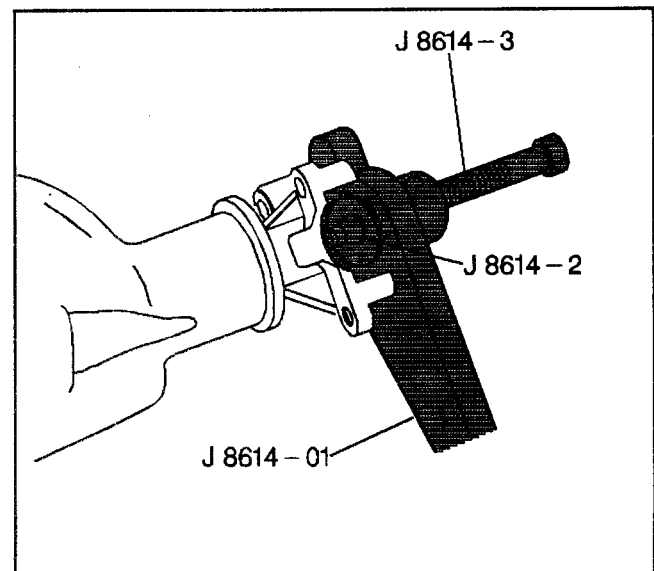

1494



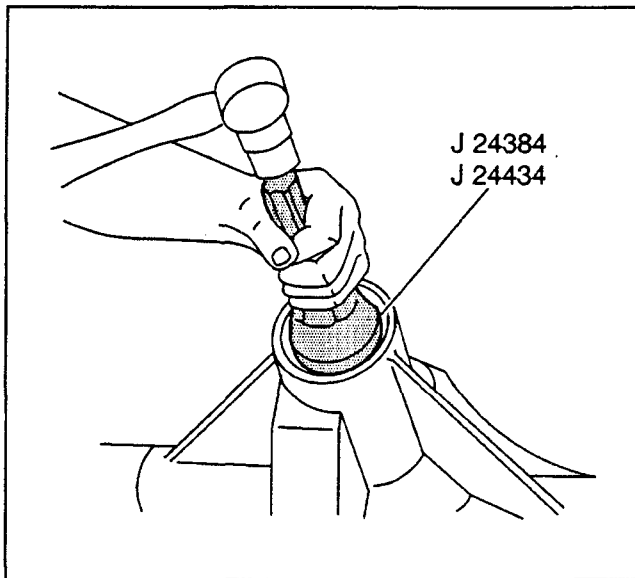

156490

### Installation Procedure

1. Lubricate the inside diameter of the new oil seal with extreme pressure lubricant such as P/N 9985038.
2. Install the oil seal into the bore using the J 24384.

**Important:** Do not coat the bearing.

3. Pack the cavity between the pinion stem, pinion flange and pinion nut with a non-hardening sealer such as Permatex® Type A or the equivalent.

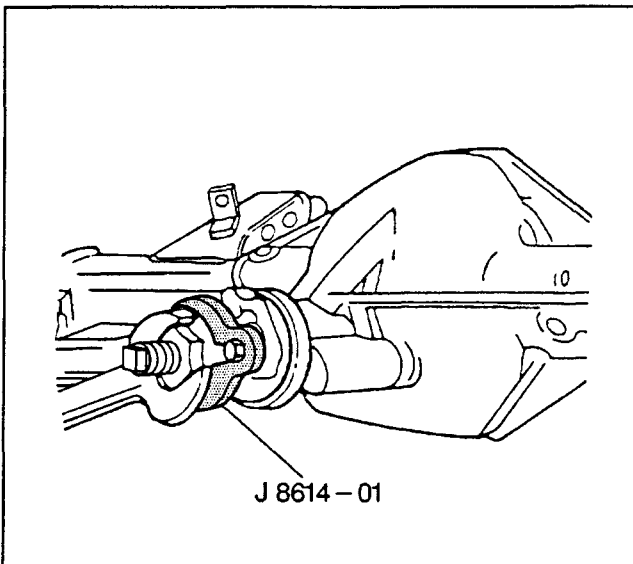

156437

4. Install the pinion flange using the J 8614-01 and use the alignment marks as a guide.

**Notice:** Refer to *Fastener Notice* in Cautions and Notices.

5. Install the pinion nut using the J 8614-01 and use the alignment marks as a guide.

### Tighten

Tighten the pinion nut to 596–678 N·m (440–550 lb ft).

6. Install the propeller shaft. Refer to *Propeller Shaft Replacement (One-Piece)* or *Two-Piece Propeller Shaft Replacement* or *Three-Piece Propeller Shaft Replacement*.

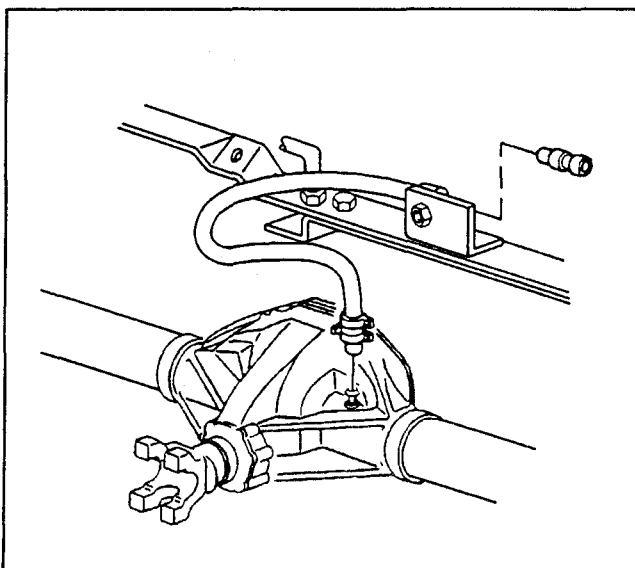

177292

### Vent Hose Replacement

The axle vent hose is on the right axle tube on 11 inch ring gear axles.

### Removal Procedure

1. Remove the vent clamp bolt from the brake bracket.
2. Remove the clamp from the brake bracket.
3. Remove the vent assembly from the hose.
4. Remove the clamp from the hose.
5. Remove the hose clamp bolt from the hose clamp.
6. Remove the hose clamp from the axle nipple.
7. Remove the hose clamp from the hose.

### Installation Procedure

1. Install the hose clamp to the hose.
2. Install the hose clamp and the hose to the axle nipple.
3. Install the hose clamp bolt to the hose clamp.
4. Install the clamp to the hose.
5. Install the vent assembly to the hose.
6. Install the clamp to the brake bracket.
7. Install the vent clamp bolt to the brake bracket.

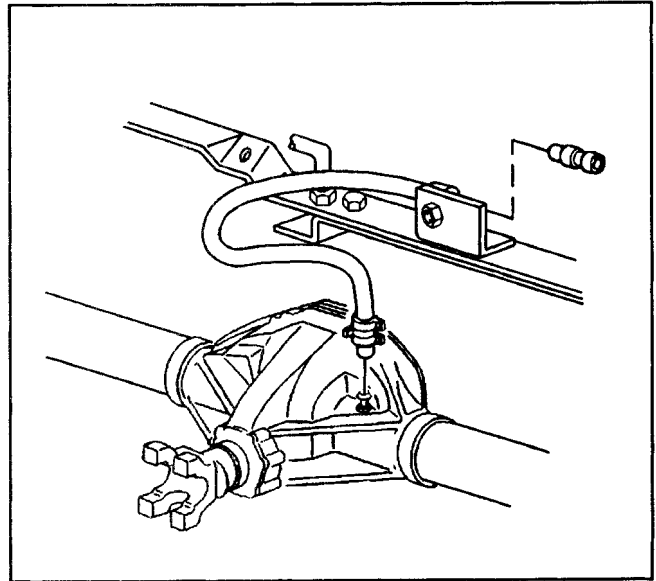

177292

### Inspection Before Disassembly

1. Remove the cover and drain the oil.

**Important:** Use this information in the diagnosis of an axle problem. Information on ring gear backlash also helps in setting shim packs for locating and preloading the differential case.

2. Check the ring gear backlash. Refer to *Backlash Adjustment*.

**Important:** If possible, determine the cause the axle problem before disassembly of the axle.

3. Inspect the case for metal chips and shavings. Determine where the chips and shavings came from, such as a broken gear or bearing cage.

### Drive Axle Disassemble

#### Tools Required

- J 8107-2 Side Bearing Puller Plug
- J 8614-01 Pinion Flange Holder
- J 24385-01 Differential Housing Spreader
- J 29721 Differential Side Bearing Remover
- J 29721-70 Side Bearing Adapters
- J 39330 Bearing Race Remover
- J 39331 Outer Bearing Race Remover
- J 39704 Dial Indicator
- J 39709 Universal Handle

1. Place the axle in a suitable support.
2. Remove the bolts from the cover and the cover. This will drain the oil.
3. Pull the axle shafts out of the axle housing to the point where the axle shafts are clear of the differential case.
4. Remove the bearing cap bolts.

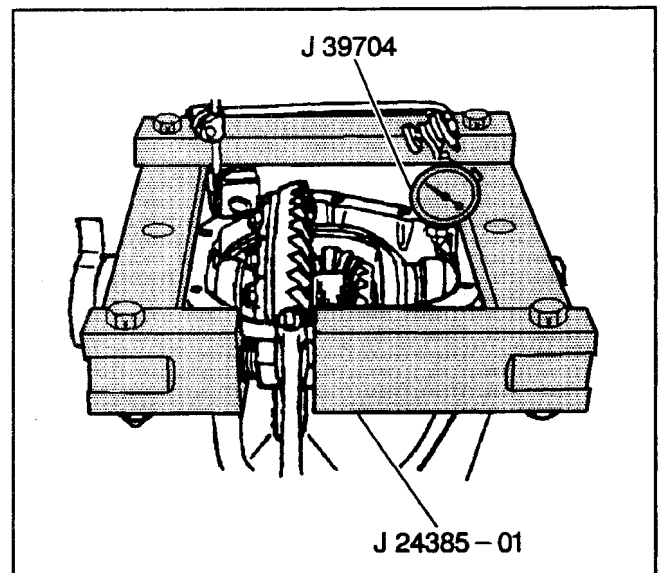

168044

**Important:** Corresponding letters are stamped on the bearing caps and axle housing. The bearing caps must be reassembled exactly as removed.

5. Remove the bearing caps.
6. Assemble the *J 24385-01* to the differential housing.

**Notice:** You may use the older style gage set if you already have them. The new style gages use the bearings as part of the gage system, while the older style uses a master block that acts as a master bearing.

7. Assemble the *J 39704*.
8. Preset the gage to a minimum of 5 mm (0.200 in). Rotate the indicator housing to zero on the dial.

**Notice:** Do not spread the axle housing more than 0.38 mm (0.015 inch). Overspreading the housing can damage or distort it.

9. Spread the housing while examining the *J 39704*.
10. Remove the case from the housing using two pry bars.
11. Remove the *J 24385-01* from the housing.

**Important:** Mark the bearing cups left and right and place each bearing cup with the corresponding proper bearing cap.

12. Remove the bearing caps.

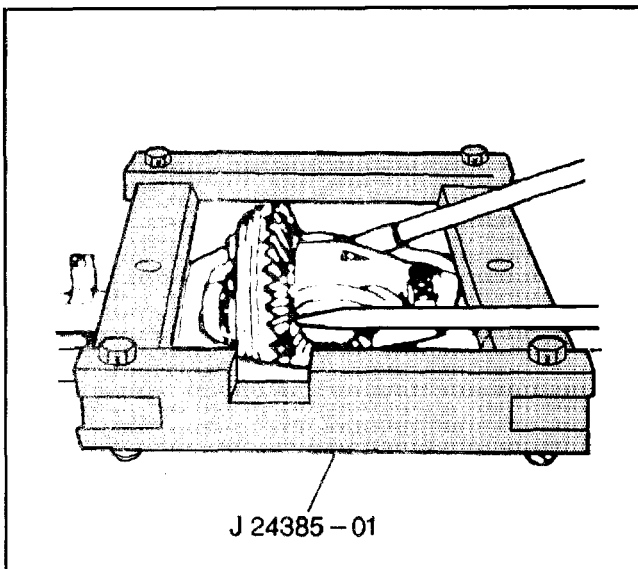

168049

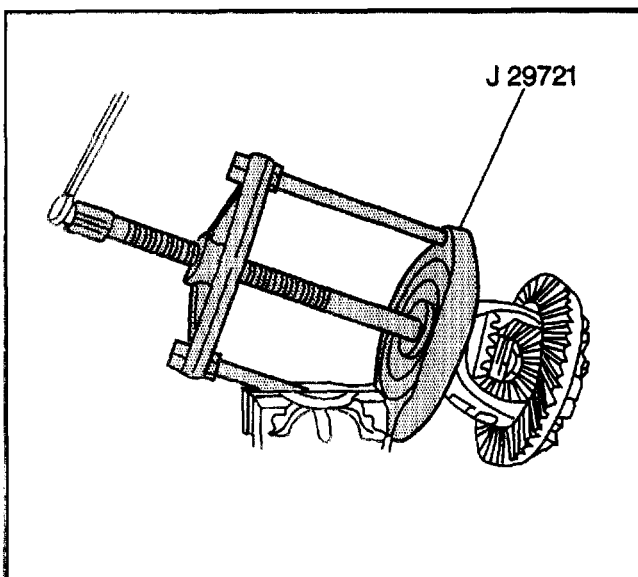

168046

**Important:** Mark the bearings left and right and place each bearing with the corresponding set of bearing cap and cup.

13. Remove the bearings using the *J 8107-2 J 29721* and *J 29721-70*

**Important:** Mark the shims left or right.

14. Remove the shims.
15. Check the outboard spacers for damage such as bends or deep grooves caused by worn bearings. Replace any damaged spacers at the time of assembly.
16. Place towels over the jaws of the vice. Place the differential case in the vice

**Important:** Replace the ring gear bolts with new ones at the time of assembly.

17. Remove the ring gear bolts. Discard the ring gear bolts.

**Notice:** Do not pry the ring gear from the case. This will damage the ring gear and differential case.

18. Remove the lock pin screw.

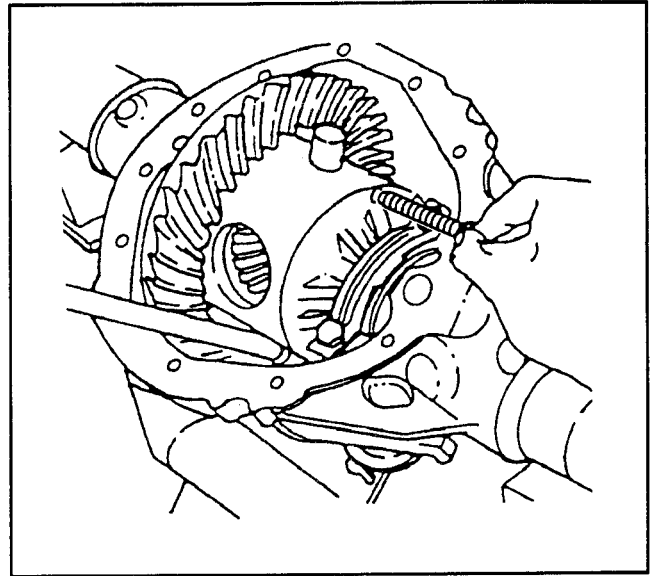

156409

19. Remove the pinion shaft using a hammer and brass drift.

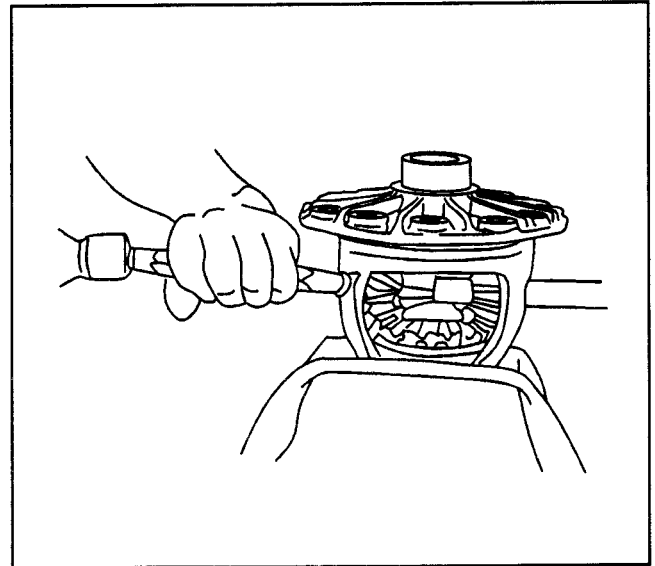

168055

20. Rotate the side gears until the pinion gears are in the opening of the case. Remove the pinion gears and thrust washers.

**Important:** Mark the side gears and thrust washers left and right

21. Remove the side gears and thrust washers.

22. Replace the cover using two bolts in order to keep the pinion from falling.

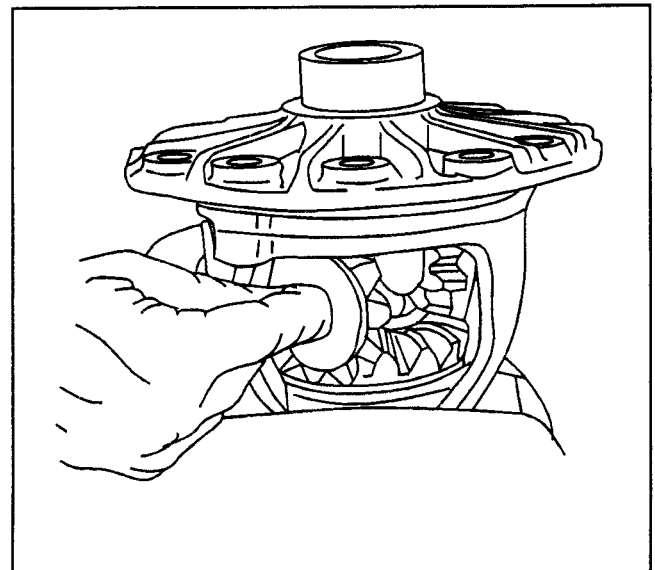

168057

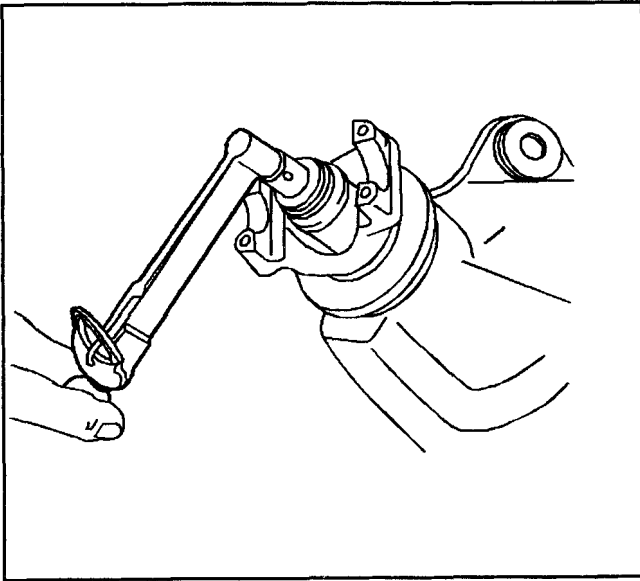

1497

23. Measure the drive pinion rotating torque. Record the measurement.
24. Check for looseness of the pinion assembly by moving the assembly back and forth. Looseness indicates excessive bearing or pinion wear.

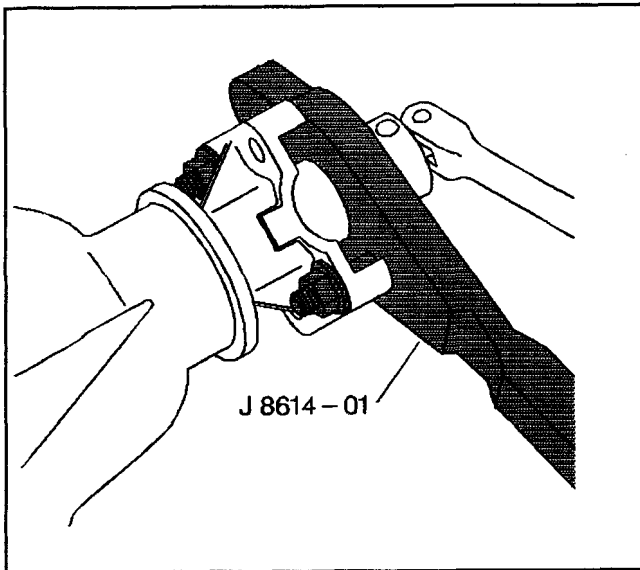

1496

25. Remove the pinion nut and washer using the *J 8614-01* in order to hold the pinion.

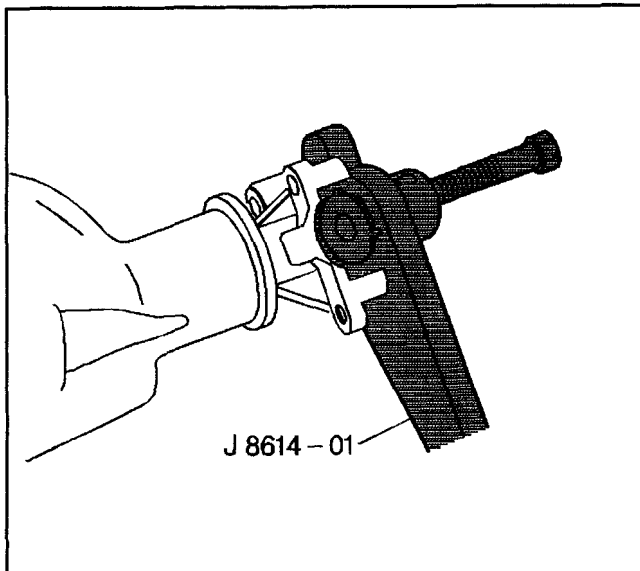

1495

26. Remove the pinion flange using the *J 8614-01*.
27. Use a soft-faced hammer to tap the pinion in order to remove the pinion from the pinion bore.
28. Remove the cover and the pinion from the vehicle.

**Important:** Keep the shims together

29. Remove the pinion preload shims.
30. Remove the pinion seal.
31. Remove the outer bearing and oil slinger.
32. Remove the pinion outer bearing cups from the axle using *J 39330*.

**Important:** Keep the shims together.

33. Remove the pinion outer adjusting shims and baffle, if used.
34. Remove the pinion inner bearing cup using the *J 39331*.

**Important:** Keep the shims together

35. Remove the pinion outer adjusting shims and baffle, if used.
36. Remove the pinion inner bearing using the *J 29721* and the *J 29721-70*.

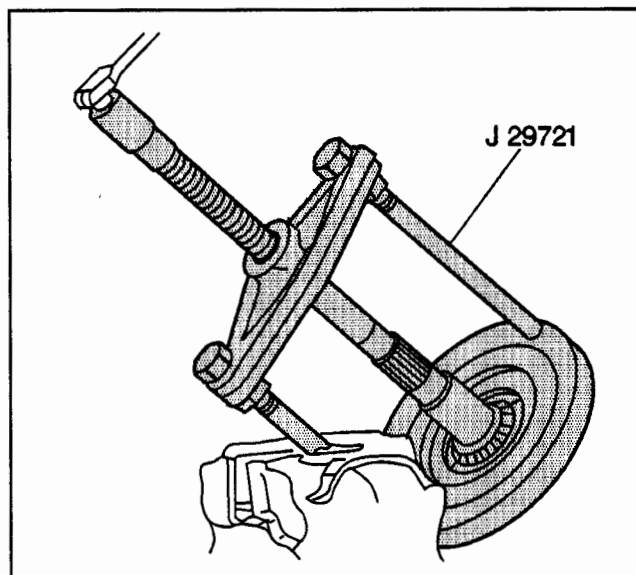

168059

### Axle Housing Inspection

Carefully and thoroughly inspect all drive unit parts before assembly. Thorough inspection of the drive parts for wear or stress with subsequent replacement of worn parts eliminates costly drive component repair after assembly.

- Inspect for nicks or burrs that could prevent the outer diameter of the pinion seal from sealing. Remove any burrs.
- Inspect the bearing cup bores for nicks or burrs. Remove any burrs that are found.
- Inspect the housing for cracks. Replace the housing if any cracks are found.
- Inspect the housing for foreign material such as metal chips, dirt, or rust.

### Differential Inspection

Carefully and thoroughly inspect all drive unit parts before assembly. Thorough inspection of the drive parts for wear or stress with subsequent replacement of worn parts eliminates costly drive component repair after assembly.

- Inspect the pinion gear shaft for unusual wear.
- Inspect the pinion gear and side gear teeth for wear, cracks, scoring, and spalling.
- Inspect the thrust washers for wear.
- Inspect the fit of the side gears in the differential case.
- Inspect the fit of the side gears on the axle shafts.
- Inspect the differential case for cracks and scoring.
- Inspect all parts for wear. Replace parts as necessary.

### Pinion and Ring Gear Inspection

Carefully and thoroughly inspect all drive unit parts before assembly. Thorough inspection of the drive parts for wear or stress with subsequent replacement of worn parts eliminates costly drive component repair after assembly.

**Important:** Ring and pinion gears are matched sets and both are replaced any time a replacement of either is necessary.

- Inspect the pinion and ring gear teeth for cracking, chipping, scoring, and excessive wear.
- Inspect the pinion gear splines for wear.
- Inspect the pinion flange splines for wear.
- Inspect the fit of the pinion gear splines on the pinion flange.
- Inspect the sealing surface of the pinion flange for nicks, burrs, or rough tool marks that could cause damage to the inside diameter of the seal and result in an oil leak.
- Replace all worn or broken parts.

### Bearings Inspection

Carefully and thoroughly inspect all drive unit parts before assembly. Thorough inspection of the drive parts for wear or stress with subsequent replacement of worn parts eliminates costly drive component repair after assembly.

**Important:** Bearings and cups are matched sets. Replace both bearing and cup when either part requires replacement.

- Oil the bearings. Inspect the bearings for smooth rotation.
- Inspect the bearing rollers for wear.
- Inspect the bearing cups for wear, cracks, brinelling, and scoring.

### Shims Inspection

Carefully and thoroughly inspect all drive unit parts before assembly. Thorough inspection of the drive parts for wear or stress with subsequent replacement of worn parts eliminates costly drive component repair after assembly.

Inspect shims for cracks and chips. Replace damaged shims with a service shim of an equal size.

### Pinion Depth Adjustment

**Tools Required**

- J 7818 Rear Pinion Bearing Cup Installer
- J 8092 Driver Handle
- J 39701 Master Discs
- J 39702 Arbor
- J 39704 Dial Indicator
- J 39707 Cup Installer
- J 39708 Handle
- J 41689 Pinion Height Block
- J 41690 Master Pinion Block
- J 41691 Adapter Cone
- J 41692 Threaded Rod

1. Clean the carrier bores and all tools. Make sure the pinion bore is free of nicks and dirt.

**Important:** Make sure the cup is seated.

2. Drive the inner bearing cup into the axle assembly using the J 39708 and J 39707

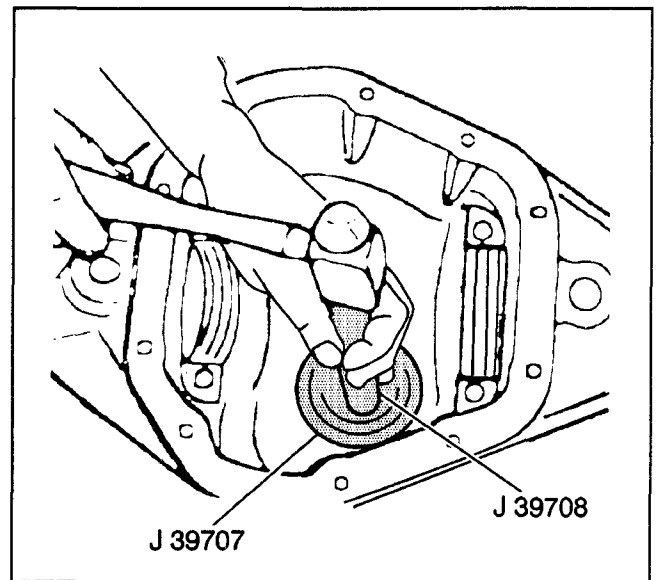

168086

### Pinion Depth Adjustment

Pinion Marking	Distance Between Ring Gear Marking And Pinion Head	Shim Pack
Positive (+)	Must Increase	Decrease
Negative (-)	Must Decrease	Increase
Zero (0)	OK	Use Nominal Setting

3. Drive the outer bearing cup into the axle assembly using the J 7818 and J 8092.

4. Install the inner bearing cone into the inner bearing cup.

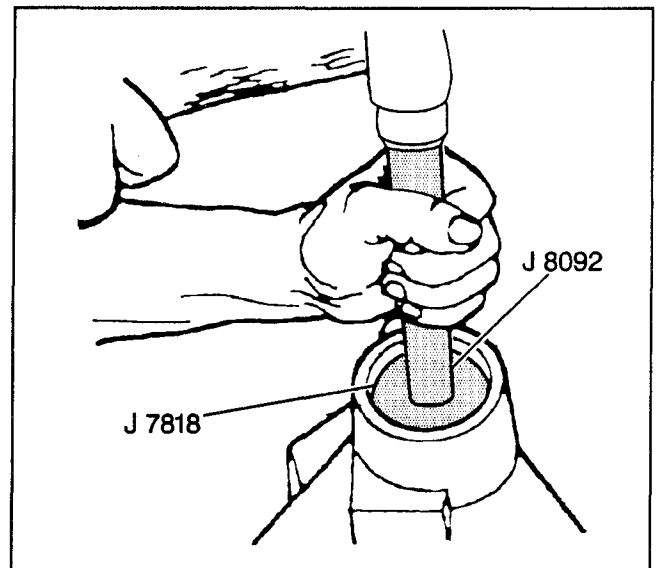

168079



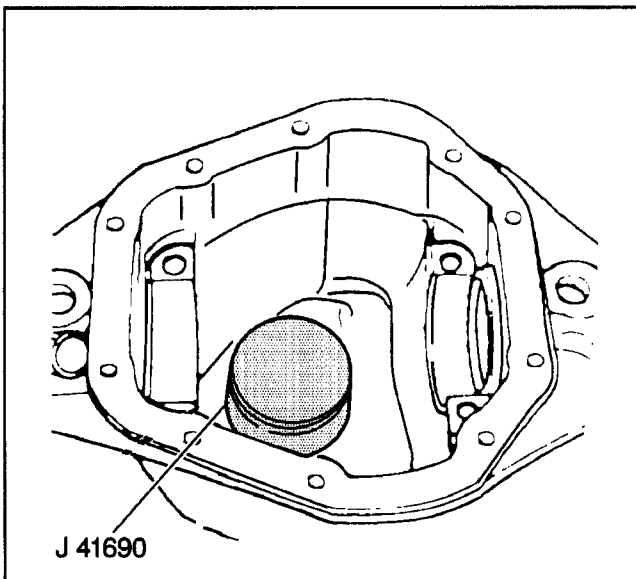

168083

**Notice:** You may use the older style gage set if you already have them. The new style gages use the bearings as part of the gage system, while the older style uses a master block that acts as a master bearing.

**Important:** Install the outer bearing cone with the J 41691.

5. Assemble the J 41690 and J 41689 into the carrier housing using the J 41691 and J 41692.
6. Tighten the cone by hand until all end play is removed from the gage assembly.
7. Assemble the J 39702 and J 39701 into the carrier housing.

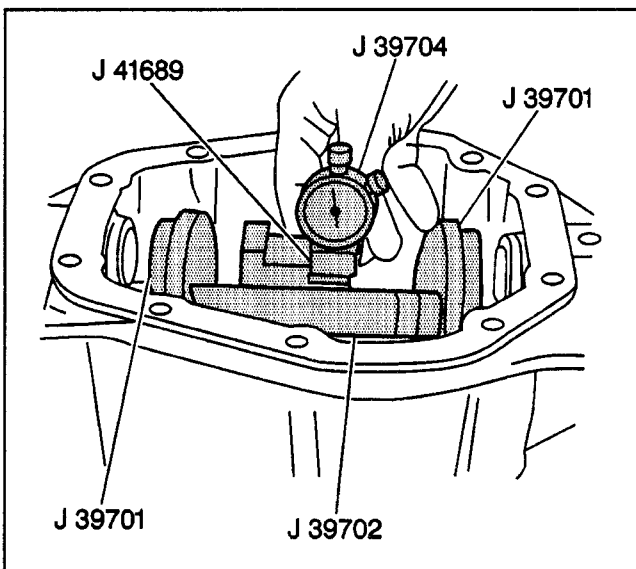

168399

8. Place the J 39704 on the upper step of the J 41689.
  - Apply pressure to the block of the J 39704, pushing down on the J 41689.
  - While applying pressure, set the J 39704 at zero.

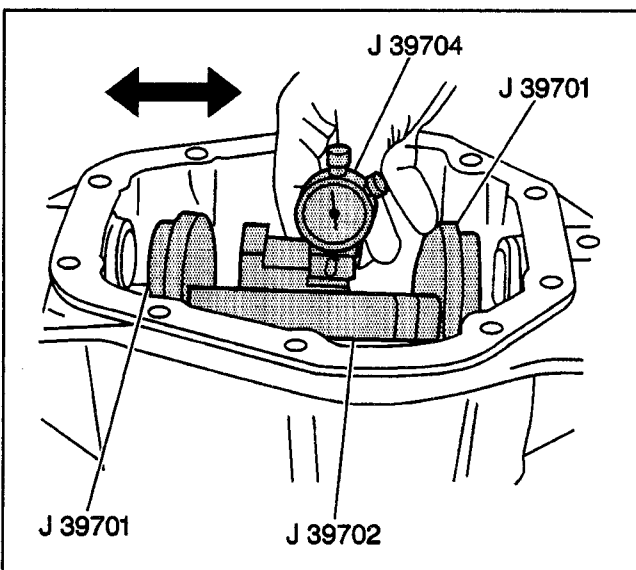

168401

9. Slide the J 39704 over the J 39702.
10. Record the reading at the point of greatest deflection, when the needle of the J 39704 is centered between movement to the left and right.
  - This reading determines the amount of shims needed for a nominal pinion setting.
  - The pinion marking may change the pinion depth by adding or deleting shims.
  - Refer to the pinion marking table.
11. After determining the pinion marking, remove the J 39704, J 39702, J 41689, J 41692, J 41691, and J 41690.

**Important:** If a baffle or oil slinger is used, measure the baffle or oil slinger. Include this measurement in the shim pack.

12. Measure with a micrometer each shim separately. Add the dimensions in order to obtain the total shim pack thickness.

## Differential Case Assembly

### Tools Required

- J 24385-01 Differential Case Spreader
- J 39705 Master Differential Bearings

1. Lubricate all parts with an axle lubricant.
2. Install new thrust washers to the side gears.

**Important:** Install the side gears to the same side that the side gears were on when removed.

3. Install the side gears to the differential case.
4. Install the pinion gears to the differential without the thrust washers.
  - 4.1. Install the pinion gears to the side gears so that the holes in the pinion gears are 180 degrees apart.
  - 4.2. Rotate the pinion gears into place. Verify that the pinion gears line up with the pinion shaft holes.
5. Rotate the pinion gears toward the differential opening in order to allow enough space for the pinion thrust washers to slide in.
6. Install the pinion shaft.
7. Align the roll pin holes in the differential case and the pinion shaft.
8. Install the roll pin.
  - 8.1. Peen metal from the case over the lock pin in two places that are 180 degrees apart.
  - 8.2. Make sure the mating surfaces of the differential case and the ring gear are clean and free of burrs.
9. Align the holes in the differential case and the holes in the ring gear. Press the ring gear onto the case.

**Important:** Tighten the ring gear bolt in stages in order to gradually pull the ring gear onto the differential case.

10. Install new ring gear bolts.

### Tighten

Tighten the ring gear bolts in sequence to 298 N·m (220 lb ft).

**Notice:** Refer to *Fastener Notice* in Cautions and Notices.

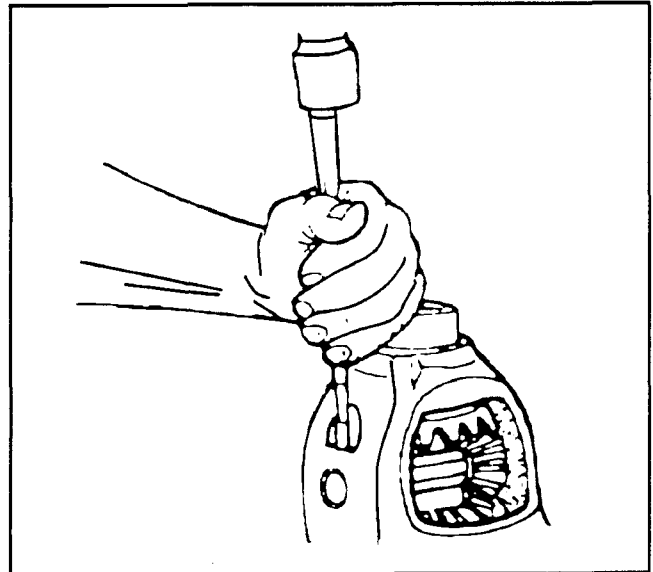

168067

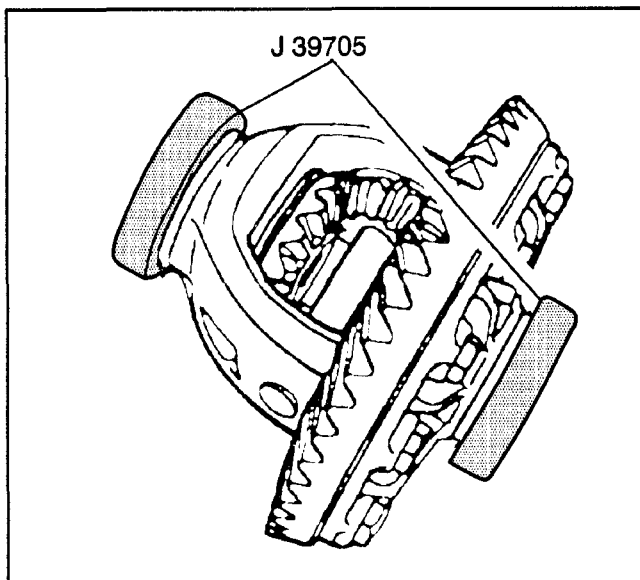

168068

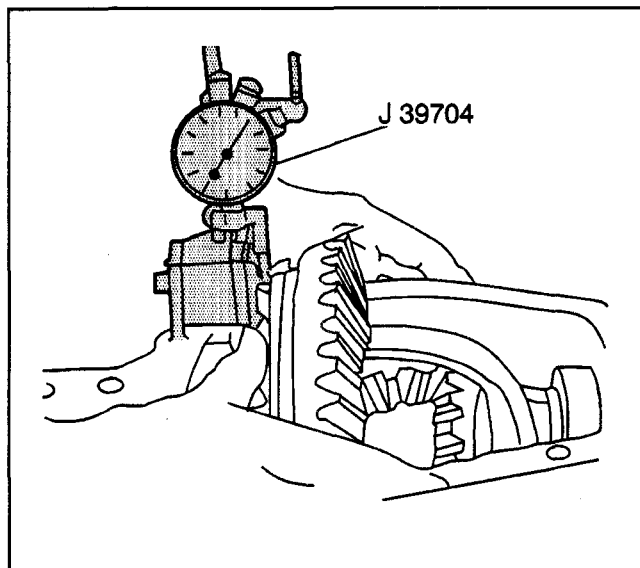

168076

11. Install the *J 39705* to the differential.

- Refer to *Determining Total Shim Pack Size* in this section.
- Put the outboard spacers in place, if outboard spacers are used.

### Determining Total Shim Pack Size

#### Tools Required

*J 39704* Dial Indicator

**Important:** Both methods for setting differential bearing preload and gear backlash are described. All Model 80 axle assemblies can be serviced by using the outboard selective shim method.

**Notice:** If the original axle assembly has the outboard selective shims, it should not be serviced using the inboard shims for preload/backlash adjustment. In other words, if you have outboard selective shims, you must stay with that method. If the axle assembly uses inboard shims and outboard spacers (non-selective), you may use the outboard selective shim method for service.

**Notice:** If your axle assembly has selective outboard spacers and one 0.76 mm (0.030 inch) shim (each side) between the differential case and bearing cone. Make your measurements with the outboard spacers removed, but with the 0.76 mm (0.030 inch) shim assembled on the differential case trunion placed between the case and the master differential bearings. The selective outboard spacers are available in sizes (thickness) from 5.18 mm (0.2040 inch) to 6.10 mm (0.2400 inch), in 0.08 mm (0.003 inch) increments. The dial indicator should have the capability of making measurements up to 12.7 mm (0.500 inch).

**Notice:** If your axle assembly has outboard spacers, but controls the preload and backlash by using selective shims (each side) between the differential case and bearing cone. Make the measurements with the outboard spacers installed in the housing, but do not place any shims on the differential case hubs between the case and master differential bearings. The selective shims placed between the bearing cone and differential case are available in 0.08, 0.13, 0.25, 0.76 mm (0.003, 0.005, 0.010, 0.030 inch) sizes. The dial indicator should have the capability of making measurements up to 3.81 mm (0.150 inch).

1. Assemble the case to the axle housing. The pinion must not be installed.
2. Mount the *J 39704* on the ring gear bolt side of the differential housing.
3. Force the differential assembly as far as possible in the direction of the *J 39704*.
4. Preload the *J 39704* one half of its travel.
5. Place the tip of the *J 39704* on a flat surface of the differential next to a ring gear bolt.
6. Mark with chalk the location of the tip of the *J 39704*.
7. Zero the dial indicator.
8. Force the differential case as far as possible in the direction away from the *J 39704*. Repeat this step until the same reading is obtained.
9. Record the number of thousandths that the dial indicator traveled, not the reading on the dial. This is the measurement of the shim pack without the bearing preload, which will be added later.
10. Remove the *J 39704*.

**Important:** Do not remove the *J 39704* from the differential.

11. Remove the differential from the housing.

**Important:** Removal of the spacers prevents the spacers from falling out during the installation of the pinion gear. Mark the spacers and indicate from which side you removed the spacers. Reassemble the spacers as removed in order to ensure that the shim pack measurement is correct.

12. Remove any spacers used in the procedure from the housing.

## Pinion Installation

### Tools Required

- *J 5590* Rear Pinion Bearing Cone Installer
- *J 8614-01* Pinion Flange Remover
- *J 39707* Rear Pinion Bearing Cup Installer
- *J 39708* Handle
- *J 41696* Pinion Seal Installer

1. Place the required amount of shims in the inner bearing bore. Include the baffle, if used.
2. Drive the inner bearing cup into the axle assembly using the *J 39708* and *J 39707*. Make sure the cup is seated on the shims.

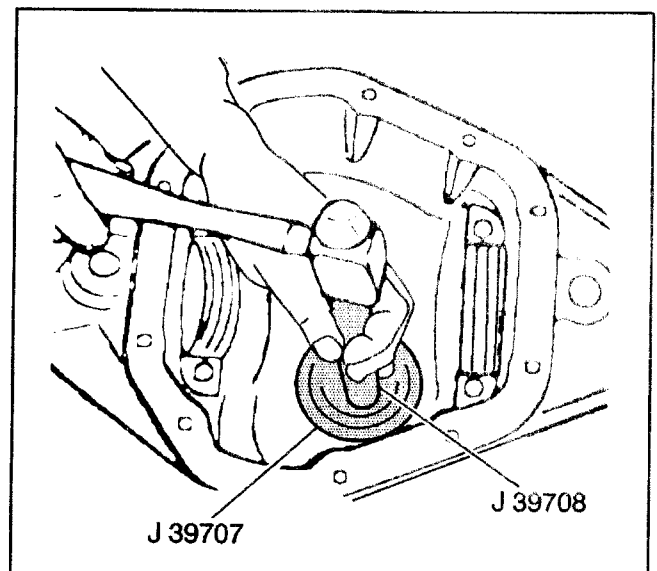

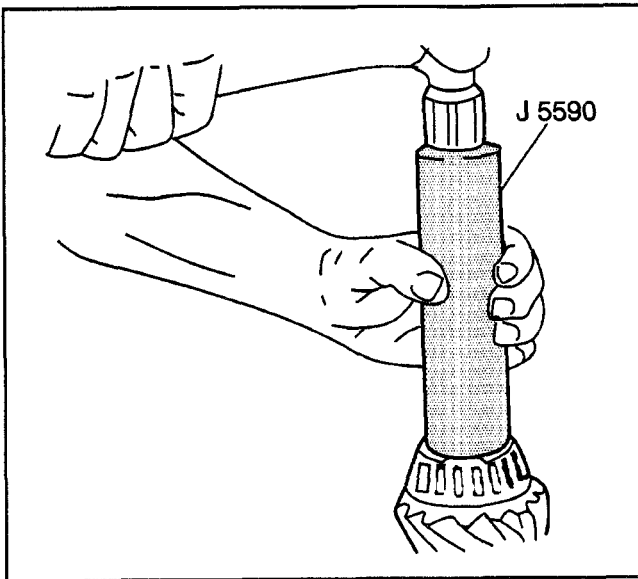

168087

3. Install the inner bearing cone on the pinion. Drive the inner bearing cone onto the pinion shaft using the *J 5590*.
4. Apply a light coat of axle lubricant to the lip of the pinion seal.
5. Install the outer bearing cone, slinger, and oil seal using the *J 41689*.
6. Install the preload shims onto the pinion gear.
7. Install the pinion into the axle housing.

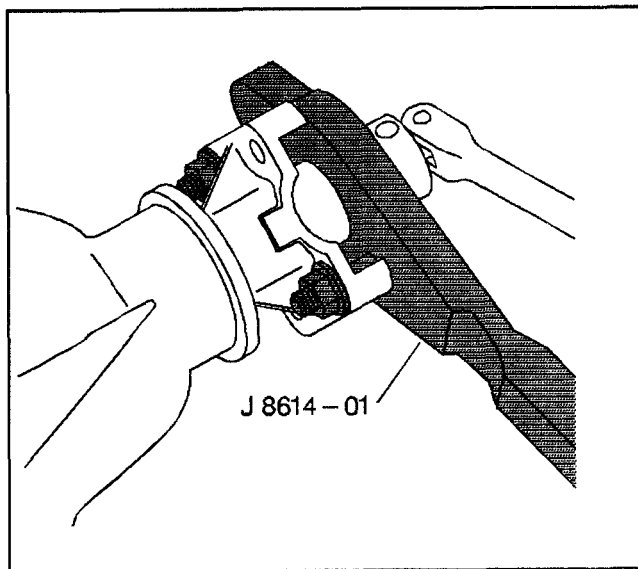

1496

**Notice:** Refer to *Fastener Notice* in Cautions and Notices.

8. Install the washer and new pinion nut.

#### Tighten

Tighten the pinion nut to 637 N·m (470 lb ft) while holding the pinion with the *J 8614-01*.

9. Tighten the nut until the pinion end play is just taken up. Rotate the pinion while tightening the nut in order to seat the bearings.
10. Once there is no end play, check the preload torque.
11. Remove the *J 8614-01*.

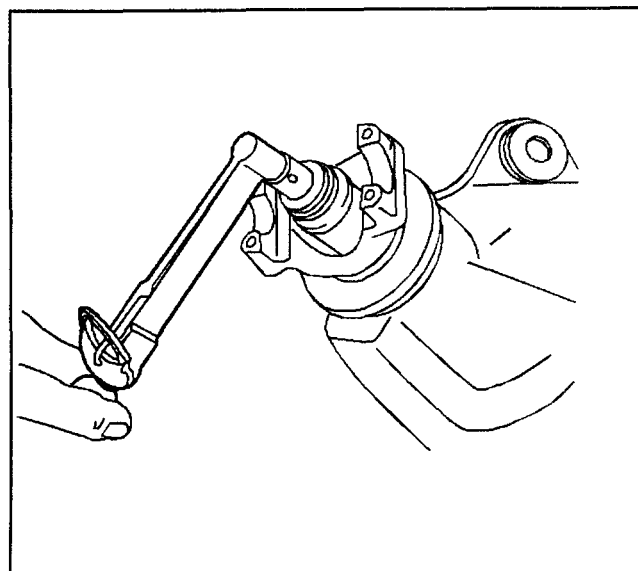

1497

**Important:** The pinion preload should be at or below 4 N·m (35 lb in) on new bearings, or 1.2 N·m (10 lb in) on old bearings.

12. Check the pinion preload by rotating the pinion with a torque wrench.
13. Once the specified preload has been obtained, make sure the bearings are seated by rotating the pinion several times.
14. Recheck the pinion preload. Adjust the pinion preload as necessary.

## Differential to Axle Housing Assemble

### Assembling The Differential Into the Axle

- *J 8001* Dial Indicator Set
- *J 8092* Driver Handle
- *J 23690* Differential Side Bearing Installer
- *J 24385-01* Differential Housing Spreader
- *J 39704* Master Differential Bearings

**Notice:** If your axle assembly has selective outboard spacers and one 0.76 mm (0.030 inch) shim (each side) between the differential case and bearing cone. Make your measurements with the outboard spacers removed, but with the 0.76 mm (0.030 inch) shim assembled on the differential case trunion placed between the case and the master differential bearings. The selective outboard spacers are available in sizes (thickness) from 5.18 mm (0.2040 inch) to 6.10 mm (0.2400 inch), in 0.08 mm (0.003 inch) increments. The dial indicator should have the capability of making measurements up to 12.7 mm (0.500 inch).

**Notice:** If your axle assembly has outboard spacers, but controls the preload and backlash by using selective shims (each side) between the differential case and bearing cone. Make the measurements with the outboard spacers installed in the housing, but do not place any shims on the differential case hubs between the case and master differential bearings. The selective shims placed between the bearing cone and differential case are available in 0.08, 0.13, 0.25, 0.76 mm (0.003, 0.005, 0.010, 0.030 inch) sizes. The dial indicator should have the capability of making measurements up to 3.81 mm (0.150 inch).

1. Force the ring gear to mesh with the pinion. Rock the ring gear in order to allow the gear teeth to mesh.

**Important:** The pinion must be installed

2. Assemble the differential with the master bearings installed to the axle.
3. Mount a *J 8001* with a magnetic base on the ring gear bolt side of the housing.
4. Place the indicator tip of the *J 8001* on the chalk mark made earlier.
5. With force still applied to the differential case, set the *J 8001* to zero.
6. Force the differential case away from the pinion gear in order to obtain a reading from the *J 8001*.
7. Repeat the last step until a consistent reading is obtained. Record the reading.
8. Remove the *J 8001* and the differential case from the axle housing.
9. Remove the *J 39705* from the differential case.

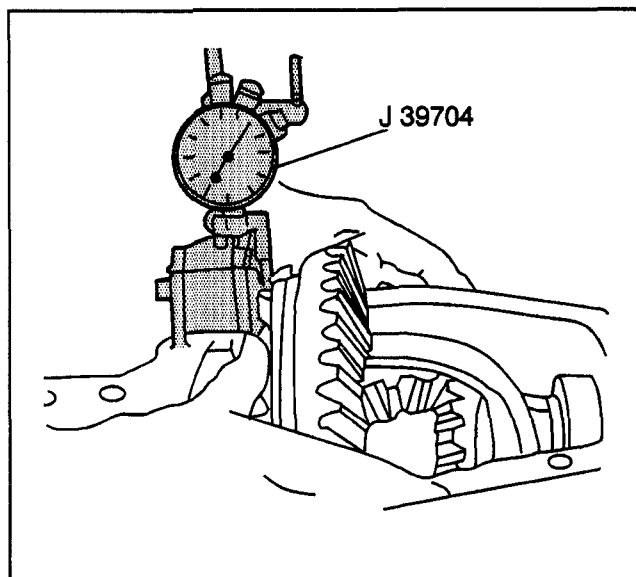

168076

10. Subtract the reading taken of the differential movement from the total shim pack size determined earlier. Refer to *Determining Total Shim Pack Size*.
  - Use the reading taken of the differential movement for the shim size on the ring gear side.
  - Use the remainder from the equation in the last step for the shim size on the side opposite of the ring gear.
  - Add an additional 0.25 mm (0.010) in) of shims to the side opposite of the ring gear in order to preload the bearings.

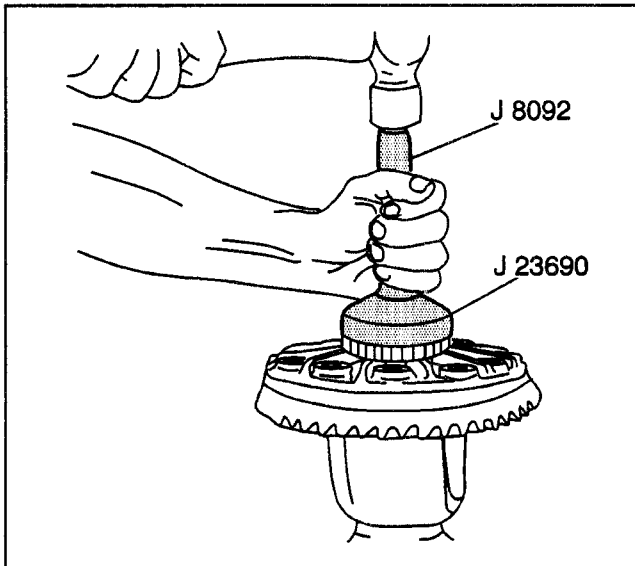

168091

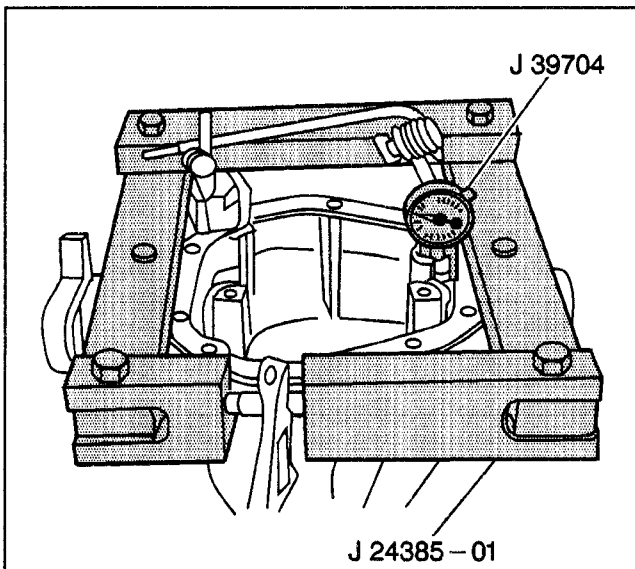

168093

- Important:** If the axle assembly uses the outboard selective spacers, place the 0.76 mm (0.030 in) shim on the hub that was used along with the master bearings to make the measurement. Then select the appropriate outboard selective spacer and assemble the outboard selective spacer into the housing.
11. Place the proper shims on the differential side of the bearing hub (ring gear side) and drive the differential bearing onto the hub using the *J 8092* and *J 23690*.

- Important:** If the axle assembly uses the outboard selective spacers, place the 0.76 mm (0.030 in) shim on the hub that was used along with the master bearings to make the measurement. Then select the appropriate outboard selective spacer and assemble the outboard selective spacer into the housing.
12. Place the proper shims on the differential side of the bearing hub (opposite of the ring gear) and drive the differential bearing onto the hub using *J 8092* and *J 23690*.
  13. Assemble the *J 24385-01* to the axle housing.
  14. Assemble the *J 8001*.
  15. Preset the *J 39704* to at least 0.05 mm (0.020 in).
  16. Rotate the indicator housing in order to zero the dial.

- Notice:** Do not spread the axle housing more than 0.38 mm (0.015 inch). Overspreading the housing can damage or distort it.
17. Spread the housing while watching the *J 8001*.
  18. Remove the *J 8001*.
  19. Place the bearing cups onto the bearings.
  20. Install the differential assembly into the carrier.
  21. Seat the differential assembly into the axle using a soft-faced hammer.
  22. Remove the *J 24385-01*.

**Important:** Install the bearing caps into the exact positions from which each had prior to removal.

23. Install the bearing caps.
- Notice:** Refer to *Fastener Notice* in Cautions and Notices.
24. Install the bearing cap bolts.

#### Tighten

Tighten the bearing cap bolts to 115 N·m (85 lb ft).

### Backlash Adjustment

#### Checking Backlash

1. Mount a *J 39704* with a magnetic base to the axle housing.

#### Backlash Adjustment

Less Than 0.13 mm (0.005 inch)	0.13–0.23 mm (0.005–0.009 inch)	Greater Than 0.23 mm (0.009 inch)
Move shims from the ring gear side to the side opposite of the ring gear	No change	Move shims from the side opposite of the ring to the ring gear side.

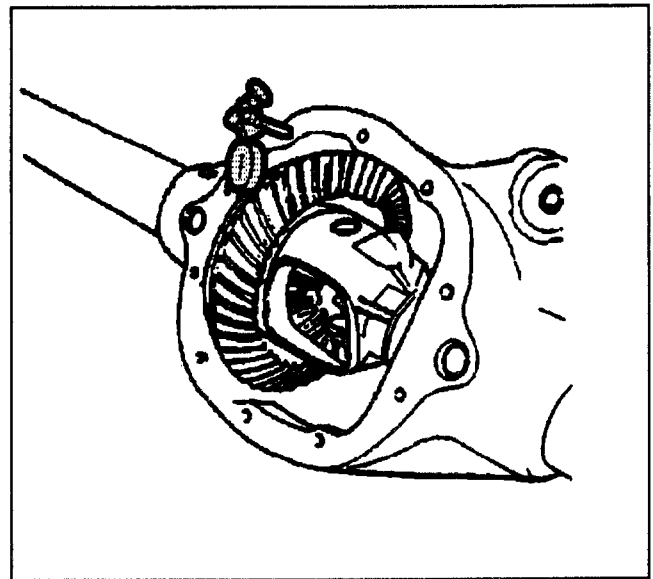

6946

2. Place the indicator tip of the *J 39704* on the heel end (1) of the ring gear tooth.

**Important:** The measurement must not vary more than 0.05 mm (0.002 in) between the points checked.

3. Check the backlash at three equally spaced points.

**Important:** The reduction in the shim pack on one side must be equal to the increase in the shim pack on the other side.

4. If the backlash needs adjustment, remove the differential case from the housing.
5. If the backlash is correct, change the preload on each side by an equal amount.
6. Make a final gear pattern check. Refer to *Gear Tooth Contact Pattern Check*.

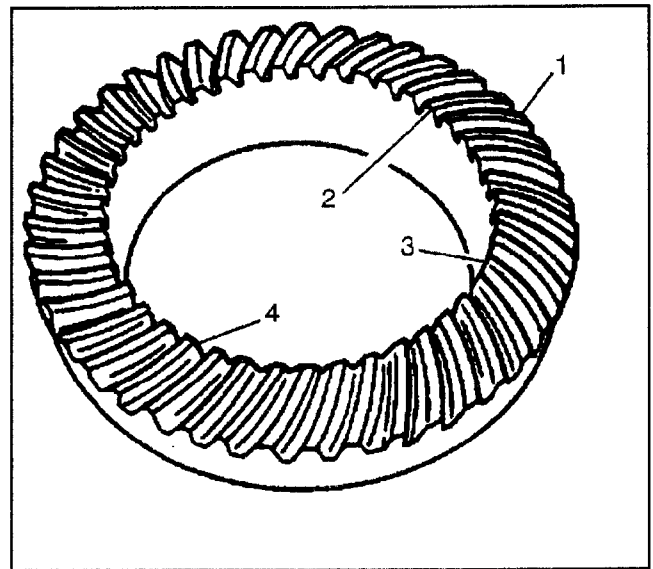

7558

### Gear Tooth Contact Pattern Check

Before final assembly of the differential, perform a gear tooth pattern check.

This contact patten check is not a substitute for adjusting the pinion depth and backlash. Use this method in order to verify the correct running position of the ring gear and drive pinion. Gear sets which are not positioned properly may be noisy, have a short life, or both. A pattern check ensures the best contact between the ring gear and the drive pinion for low noise and long life.

#### Gear Tooth Nomenclature

The side of the ring gear tooth which curves outward, or is convex, is the drive side (4). The concave side is the coast side (3). The end of the tooth nearest the center of the ring gear is the toe end (2). The end of the tooth farthest away from the center is the heel end (1).

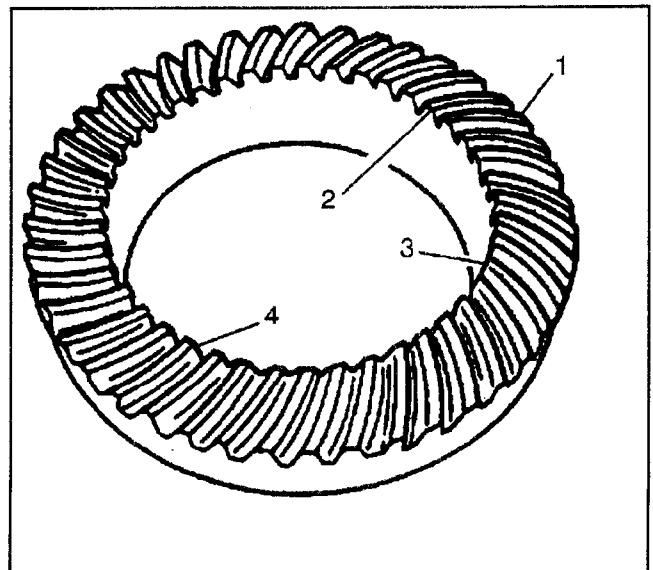

7558



**Testing Procedure**

1. Wipe the oil out of the axle housing. Carefully clean each tooth of the ring gear.
2. Use a medium stiff brush in order to sparingly apply gear marking compound to all of the ring gear teeth.

**Important:** A test made without loading the gears does not give a satisfactory pattern.

3. Use the parking brake in order to apply a load until a torque of 61 N·m (45 lb ft) is required in order to turn the pinion.

**Important:** Avoid excessive turning of the ring gear.

4. Turn the companion flange with a wrench so that the ring gear rotates one full revolution.
5. Reverse the rotation so that the ring gear rotates one revolution in the opposite direction.
6. Observe the pattern on the ring gear teeth. Compare the pattern with the following illustrations. Use the legend below:

- 6.1. (1) Toe
- 6.2. (2) Heel
- 6.3. (3) Coast side (Concave)
- 6.4. (4) Drive side (Convex)

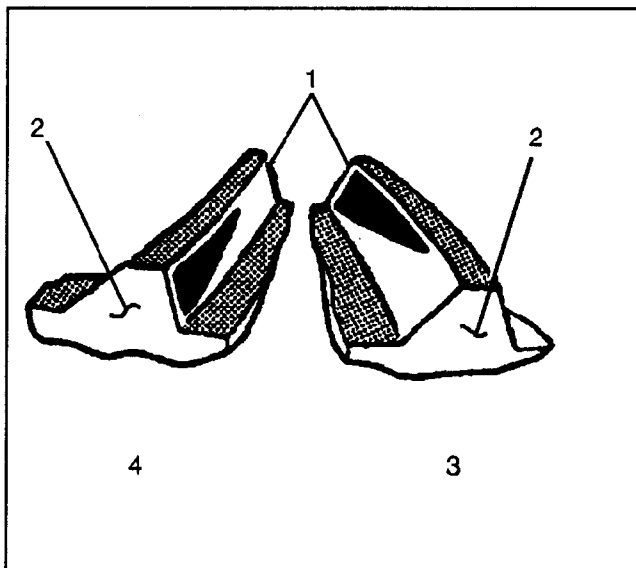

7560

**Condition**

- The backlash is correct.
- The pinion depth is incorrect. The pinion gear is too far away from the ring gear.

**Correction**

Increase the thickness of the pinion shim. Refer to *Pinion Depth Adjustment*.

**Service Hints**

How to check the pattern:

1. Brush gear marking compound on the ring gear teeth.
2. Rotate the pinion clockwise six times.
3. Rotate the pinion counterclockwise six times.
4. Observe the tooth contact pattern. Make any necessary corrections.

**Condition**

- The backlash is correct.
- The pinion depth is correct.

**Correction**

Correction may not be necessary.

**Service Hints**

Loose bearings on the pinion or in the differential case may cause patterns that vary. Check the following preload settings:

- Total assembly
- Differential case
- Pinion

If these settings are correct, look for damage or incorrectly assembled parts.

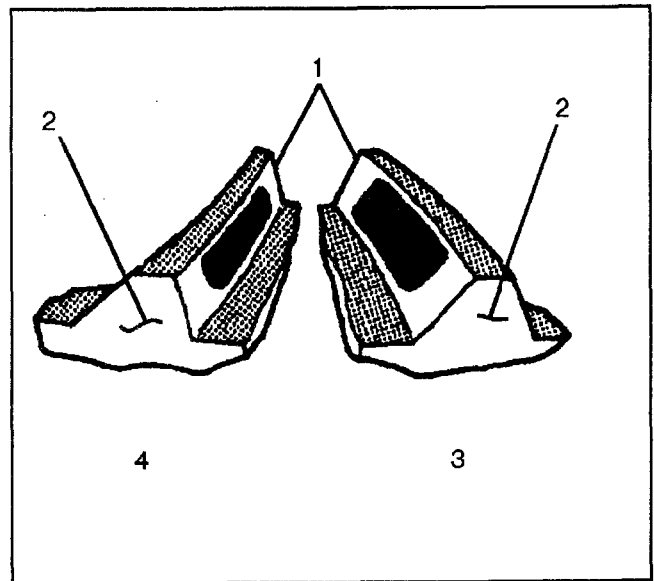

7566

**Condition**

- The backlash is correct.
- The pinion depth is incorrect.

**Correction**

Decrease the thickness of the pinion shim. Refer to *Pinion Depth Adjustment*.

**Service Hints**

The shims which adjust the pinion depth are located:

- Between the inner pinion bearing cone and the hear of the pinion gear
- Between the inner pinion bearing cup and the rear axle housing

**Adjustments Affecting Tooth Contact**

There are two adjustments that affect the tooth contact pattern: backlash and drive pinion depth. The effects of bearing preloads are not readily apparent on hand loaded tooth contact pattern tests. However, bearing preloads should be within specifications before proceeding with backlash and drive pinion adjustments.

Adjust the position of the drive pinion by increasing or decreasing the distance between the pinion head and the centerline of the ring gear. Decreasing the distance moves the pinion closer to the centerline of the ring gear. Increasing the distance moves the pinion farther away from the centerline of the ring gear.

Adjust the backlash by means of the side bearing adjusting shims which move the case and ring gear assembly closer to, or farther from, the drive pinion. Also use the adjusting shims to set the side bearing preload.

If the thickness of the right shim is increased, along with an equal decrease in the thickness of the left shim, backlash will increase.

If the thickness of the left shim is increased, along with an equal decrease in the thickness of the right shim, the backlash will decrease.

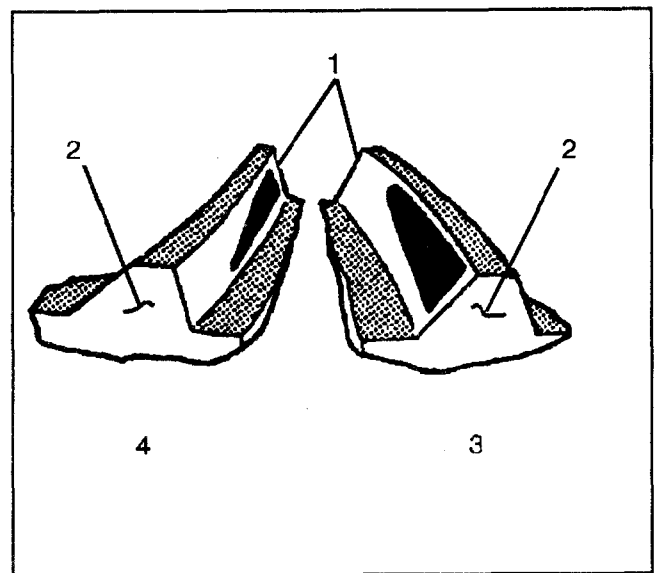

7579

## Drive Axle Final Assembly

1. Apply a thin layer of sealant to the axle cover.

**Notice:** Refer to *Fastener Notice* in Cautions and Notices.

2. Install the axle cover to the axle with the bolts.

### Tighten

Tighten the axle cover bolts to 47 N·m (35 lb ft).

3. Fill the axle with oil. Refer to *Lubrication Specifications*.
4. Install the fill plug to the case.

### Tighten

Tighten the fill plug to 33 N·m (24 lb ft).

## Axle Replacement (11 in. Ring Gear)

### Removal Procedure

1. Raise the vehicle and place jack stands under the frame side rails for support.
2. Drain the lubricant from the axle housing.
3. Disconnect the propeller shaft. Refer to *Propeller Shaft Replacement (One-Piece)* or *Two-Piece Propeller Shaft Replacement* or *Three-Piece Propeller Shaft Replacement* in Propeller Shaft.
4. Remove the tire and wheel assembly.
5. Remove the hub and drum assembly or the hub and rotor assembly. Refer to *Hub and Drum Assembly Replacement (All Models)* or *Hub and Rotor Assembly Replacement*.
6. Disconnect the parking brake cable from the lever and at the brake flange plate. Refer to:
  - *Park Brake Cable Replacement (Front Pedal Type)* in Parking Brake.
  - *Park Brake Cable Replacement (Front Lever Type)* in Parking Brake.
  - *Park Brake Cable Replacement (Center)* in Parking Brake.
  - *Park Brake Cable Replacement (Actuator)* in Parking Brake.
  - *Park Brake Cable Replacement (Rear)* in Parking Brake.

7. Remove the hydraulic brake pipes from the connectors. Refer to:
  - *Brake Hose Replacement - Front (Commercial FL7 and FL9)* in Hydraulic Brakes.
  - *Brake Hose Replacement - Front (Comm. FL5/6 JB7/8 Mtrhome JB8)* in Hydraulic Brakes.
  - *Brake Hose Replacement - Front (Commercial FK4/FK5 and JF9)* in Hydraulic Brakes.
  - *Brake Hose Replacement - Front (Commercial FK4/FK5 and JB8)* in Hydraulic Brakes.
  - *Brake Hose Replacement - Front (Motorhome JF9)* in Hydraulic Brakes.
  - *Brake Hose Replacement - Front (Motorhome JB7/JB8)* in Hydraulic Brakes.
  - *Brake Hose Replacement - Rear* in Hydraulic Brakes.
8. Disconnect the shock absorbers from the axle brackets.
9. Disconnect the vent hose from the axle vent fitting. Refer to *Vent Hose Replacement*.
10. Remove the height-sensing and brake proportioning valve linkage (if equipped).
11. Support the axle assembly with a hydraulic floor jack.
12. Remove the nuts and washers from the U-bolts.
13. Remove the U-bolts, spring plates, and spacers from the axle assembly.
14. Lower the axle assembly.

### Installation Procedure

1. Place the axle assembly under the vehicle.
2. Align the axle assembly with the springs.
3. Connect the spacers, spring plates, and U-bolts to the axle assembly.
4. Raise the axle assembly.
5. Install the washers and nuts to the U-bolts.
  - Firmly thread the nuts.
  - Adjust the alignment of the axle assembly.
6. Install the height-sensing and brake proportioning valve linkage (if equipped).
7. Connect the vent hose to the axle vent fitting. Refer to *Vent Hose Replacement*.
8. Connect the shock absorbers to the axle brackets.

9. Connect the hydraulic brake pipes to the connectors. Refer to:
    - *Brake Hose Replacement - Front (Commercial FL7 and FL9)* in Hydraulic Brakes.
    - *Brake Hose Replacement - Front (Comm. FL5/6 JB7/8 Mtrhome JB8)* in Hydraulic Brakes.
    - *Brake Hose Replacement - Front (Commercial FK4/FK5 and JF9)* in Hydraulic Brakes.
    - *Brake Hose Replacement - Front (Commercial FK4/FK5 and JB8)* in Hydraulic Brakes.
    - *Brake Hose Replacement - Front (Motorhome JF9)* in Hydraulic Brakes.
    - *Brake Hose Replacement - Front (Motorhome JB7/JB8)* in Hydraulic Brakes.
    - *Brake Hose Replacement - Rear* in Hydraulic Brakes.
  10. Connect the parking brake cable to the lever and the brake flange plate. Refer to:
    - *Park Brake Cable Replacement (Front Pedal Type)* in Parking Brake.
    - *Park Brake Cable Replacement (Front Lever Type)* in Parking Brake.
    - *Park Brake Cable Replacement (Center)* in Parking Brake.
    - *Park Brake Cable Replacement (Actuator)* in Parking Brake.
    - *Park Brake Cable Replacement (Rear)* in Parking Brake.
  11. Install the hub and drum assembly or the hub and rotor assembly. Refer to *Hub and Drum Assembly Replacement (All Models)* or *Hub and Rotor Assembly Replacement*.
  12. Install the tire and wheel assembly.
  13. Connect the propeller shaft. Refer to *Propeller Shaft Replacement (One-Piece)* or *Two-Piece Propeller Shaft Replacement* or *Three-Piece Propeller Shaft Replacement* in Propeller Shaft.
- Notice:** Refer to *Fastener Notice* in Cautions and Notices.
14. Tighten all fasteners. Refer to *Fastener Tightening Specifications (Dana)*.
  15. Fill the axle assembly with axle lubricant to the filler plug hole level. Refer to *Fluid and Lubricant Recommendations*.
  16. Bleed the brake system, check brake operation and adjust if necessary. Refer to *Hydraulic Brake System Bleeding* in Hydraulic Brakes.
  17. Remove the jack stands and lower the vehicle.
  18. Check axle operation.
  19. Check for fluid leaks.
  20. Road test the vehicle.

## Axle Replacement (10 1/2 in. Ring Gear)

### Removal Procedure

1. Raise the vehicle and place jack stands under the frame side rails for support.
2. Drain the lubricant from the axle housing.
3. Remove the propeller shaft. Refer to *Two-Piece Propeller Shaft Replacement* or *Three-Piece Propeller Shaft Replacement* in Propeller Shaft.
4. Remove the tire and wheel assembly.
5. Remove the brake drum or hub and drum assembly. Refer to *Hub and Drum Assembly Replacement (All Models)*.
6. Disconnect the parking brake cable from the lever and at the brake flange plate. Refer to:
  - *Park Brake Cable Replacement (Front Pedal Type)* in Parking Brake.
  - *Park Brake Cable Replacement (Front Lever Type)* in Parking Brake.
  - *Park Brake Cable Replacement (Center)* in Parking Brake.
  - *Park Brake Cable Replacement (Actuator)* in Parking Brake.
  - *Park Brake Cable Replacement (Rear)* in Parking Brake.
7. Remove the hydraulic brake pipes from the connectors. Refer to:
  - *Brake Hose Replacement - Front (Commercial FL7 and FL9)* in Hydraulic Brakes.
  - *Brake Hose Replacement - Front (Comm. FL5/6 JB7/8 Mtrhome JB8)* in Hydraulic Brakes.
  - *Brake Hose Replacement - Front (Commercial FK4/FK5 and JF9)* in Hydraulic Brakes.
  - *Brake Hose Replacement - Front (Commercial FK4/FK5 and JB8)* in Hydraulic Brakes.
  - *Brake Hose Replacement - Front (Motorhome JF9)* in Hydraulic Brakes.
  - *Brake Hose Replacement - Front (Motorhome JB7/JB8)* in Hydraulic Brakes.
  - *Brake Hose Replacement - Rear* in Hydraulic Brakes.
8. Disconnect the shock absorbers from the axle brackets. Refer to *Shock Absorber Replacement* in Rear Suspension.

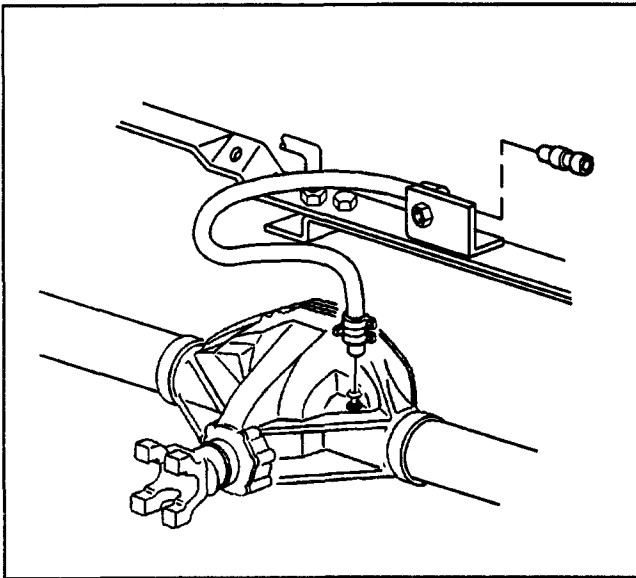

177292

9. Disconnect the vent hose from the axle vent fitting. Refer to *Vent Hose Replacement*.
10. Disconnect the height-sensing and brake proportioning valve linkage (if equipped).
11. Support the assembly with a hydraulic floor jack.
12. Remove the nuts and washers from the U-bolts.
13. Remove the U-bolts, spring plates, and spacers from the axle assembly.
14. Lower the jack and the axle assembly.

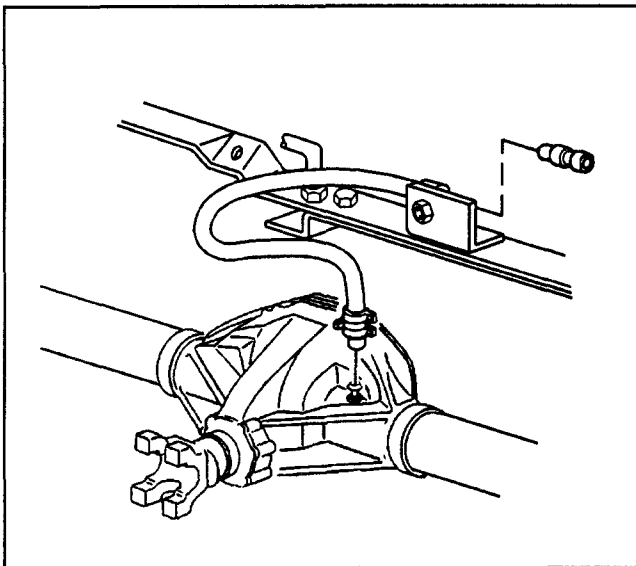

177292

### Installation Procedure

1. Install the axle assembly under the vehicle.
2. Align the axle assembly with the springs.
3. Install the spacers, spring plates, and U-bolts to the axle assembly.
4. Raise the axle assembly.
5. Install the washers and nuts to the U-bolts.
  - 5.1. Adjust the alignment of the axle.
  - 5.2. Firmly thread on the nuts.
6. Connect the height-sensing and brake proportioning valve linkage (if equipped).
7. Connect the vent hose to the axle fitting. Refer to *Vent Hose Replacement*.
8. Connect the shock absorbers to the axle brackets. Refer to *Shock Absorber Replacement* in Rear Suspension.
9. Connect the hydraulic brake pipes to the connectors. Refer to:
  - *Brake Hose Replacement - Front (Commercial FL7 and FL9)* in Hydraulic Brakes.
  - *Brake Hose Replacement - Front (Comm. FL5/6 JB7/8 Mtrhome JB8)* in Hydraulic Brakes.
  - *Brake Hose Replacement - Front (Commercial FK4/FK5 and JF9)* in Hydraulic Brakes.
  - *Brake Hose Replacement - Front (Commercial FK4/FK5 and JB8)* in Hydraulic Brakes.
  - *Brake Hose Replacement - Front (Motorhome JF9)* in Hydraulic Brakes.
  - *Brake Hose Replacement - Front (Motorhome JB7/JB8)* in Hydraulic Brakes.
  - *Brake Hose Replacement - Rear* in Hydraulic Brakes.

10. Connect the parking brake cable to the lever and the brake flange plate. Refer to:
  - *Park Brake Cable Replacement (Front Pedal Type)* in Parking Brake.
  - *Park Brake Cable Replacement (Front Lever Type)* in Parking Brake.
  - *Park Brake Cable Replacement (Center)* in Parking Brake.
  - *Park Brake Cable Replacement (Actuator)* in Parking Brake.
  - *Park Brake Cable Replacement (Rear)* in Parking Brake.
11. Install the tire and wheel assembly.
12. Install the hub and drum assembly. Refer to *Hub and Drum Assembly Replacement (All Models)*.
13. Install the propeller shaft. Refer to *Two-Piece Propeller Shaft Replacement* or *Three-Piece Propeller Shaft Replacement* in Propeller Shaft.

**Notice:** Refer to *Fastener Notice* in Cautions and Notices.

14. Tighten all fasteners. Refer to *Fastener Tightening Specifications (American Axle)* or *Fastener Tightening Specifications (Dana)*.
15. Fill the axle assembly with axle lubricant to the level of the filler plug hole. Refer to *Fluid and Lubricant Recommendations*.
16. Bleed the brake system. Refer to *Hydraulic Brake System Bleeding* in Hydraulic Brakes.
17. Check the operation of the axle and brakes. Adjust as necessary.
  - 17.1. Remove the jack stands and lower the vehicle.
  - 17.2. Check for fluid leaks.
  - 17.3. Road test the vehicle.

## Pinion Flange Replacement (10 1/2 in. Ring Gear)

### Removal Procedure

#### Tools Required

- J 8614-01 Companion Flange Holder/Remover
- J 24384 Pinion Oil Seal Installer

The pinion oil seal and the pinion flange may be replaced with the carrier assembly installed in the vehicle.

1. Raise the vehicle on a hoist and support with suitable safety stands.
2. Remove the propeller shaft. Refer to *Propeller Shaft Replacement (One-Piece)* or *Two-Piece Propeller Shaft Replacement* or *Three-Piece Propeller Shaft Replacement* in Propeller Shaft.
3. Tie the propeller shaft to a frame rail or crossmember.
4. Make an alignment mark (1) on the pinion shaft, pinion nut and companion flange (2). Use the mark as a guide during reinstallation.

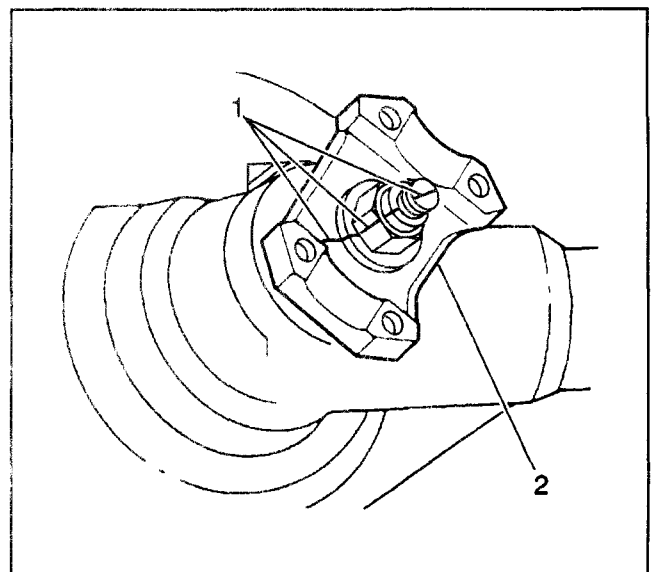

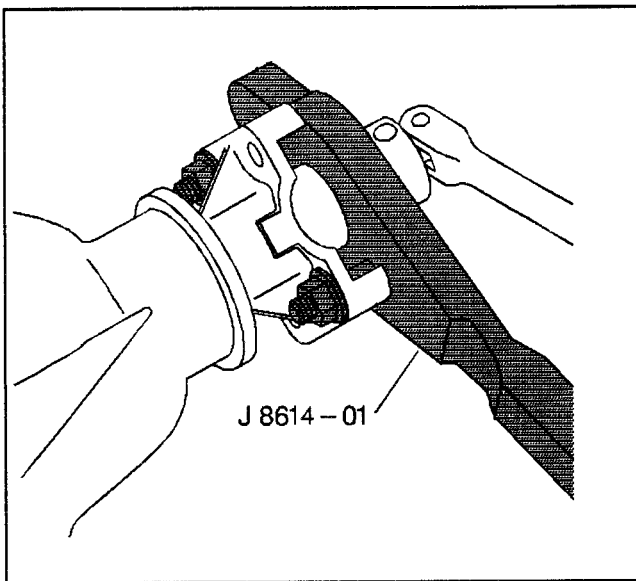

1496

- Remove the nut using the *J 8614-01*. Have a drain pan ready in order to catch the oil.

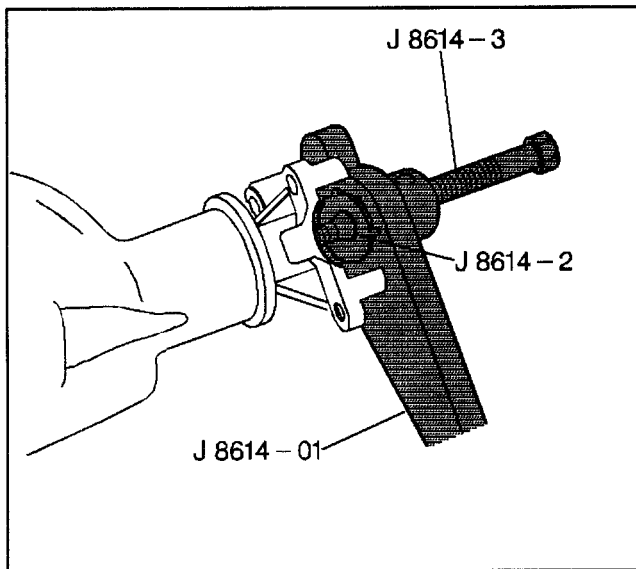

1494

- Remove the flange using the *J 8614-01*.

**Important:** Do not damage the machined surfaces.

- Pry the oil seal from the bore.
- Thoroughly clean foreign material from the contact area.
- Replace parts as necessary.

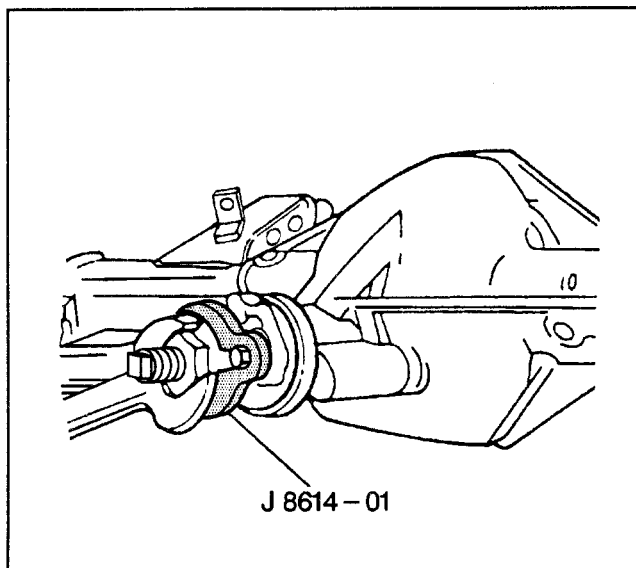

156437

### Installation Procedure

- Lubricate the cavity between the lips of the new seal with a high melting point bearing lubricant.
- Install the oil seal into the bore using the *J 24384*.

**Important:** Use the alignment marks during reinstallation.

- Install the pinion flange using the *J 8614-01*.

**Notice:** Refer to *Fastener Notice* in Cautions and Notices.

- Install the pinion nut using the *J 8614-01*.

### Tighten

- Tighten the nut to the same position marked in the removal procedure.
- Tighten the pinion nut 1/16 inch beyond the alignment mark.

5. Install the propeller shaft. Refer to *Propeller Shaft Replacement (One-Piece)* or *Two-Piece Propeller Shaft Replacement* or *Three-Piece Propeller Shaft Replacement* in Propeller Shaft.
6. Lower the vehicle.

## Pinion Flange Replacement (11 in. Ring Gear )

### Removal Procedure

#### Tools Required

- J 8614-01 Pinion Flange Holder/Remover
- J 24384 Pinion Oil Seal Installer

The pinion oil seal and the pinion flange may be replaced with the carrier assembly installed in the vehicle.

1. Raise the vehicle.
2. Disconnect the propeller shaft. Refer to *Propeller Shaft Replacement (One-Piece)* or *Two-Piece Propeller Shaft Replacement* or *Three-Piece Propeller Shaft Replacement* in Propeller Shaft.
3. Make an alignment mark (1) on the pinion stem, pinion nut and pinion flange (2) for use as an installation guide.
4. Remove the pinion nut using J 8614-01.

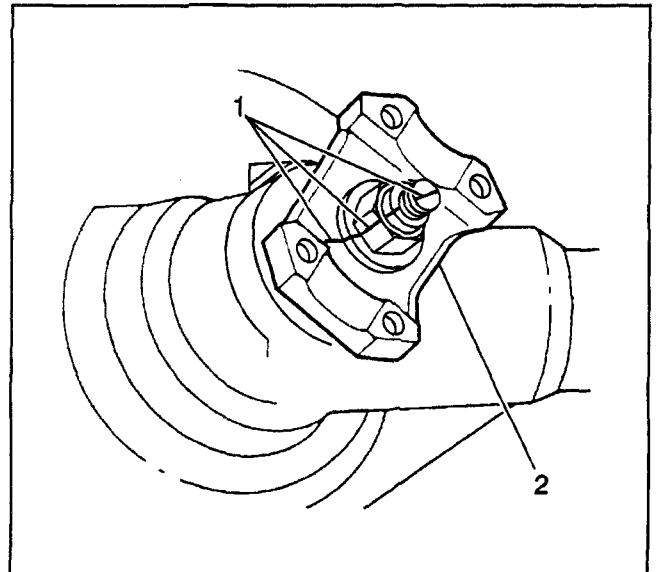

156435

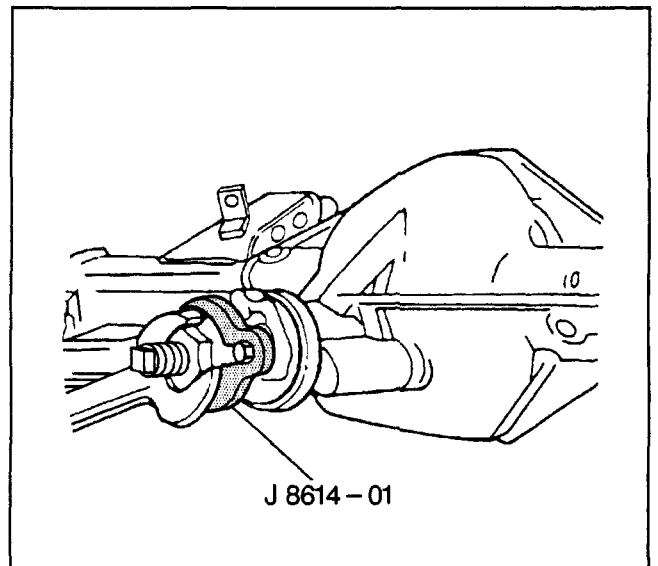

156437



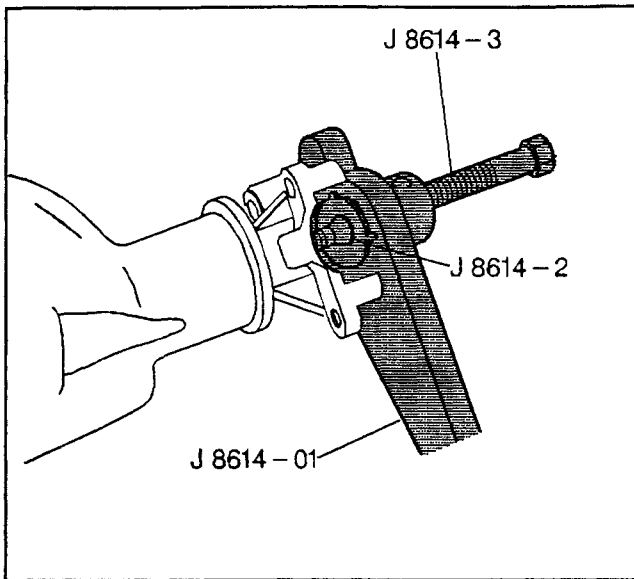

1494

5. Remove the flange using *J 8614-01* with the special nut and forcing screw.
6. Pry the oil seal from the bore.
  - Do not damage the machined surfaces
  - Clean any foreign material from the contact area
7. Inspect the oil seal mating surfaces for any burrs which may cause seal failure.
8. Inspect the flange deflector for any abnormality such as cracking or distortion.
9. Replace parts as necessary.

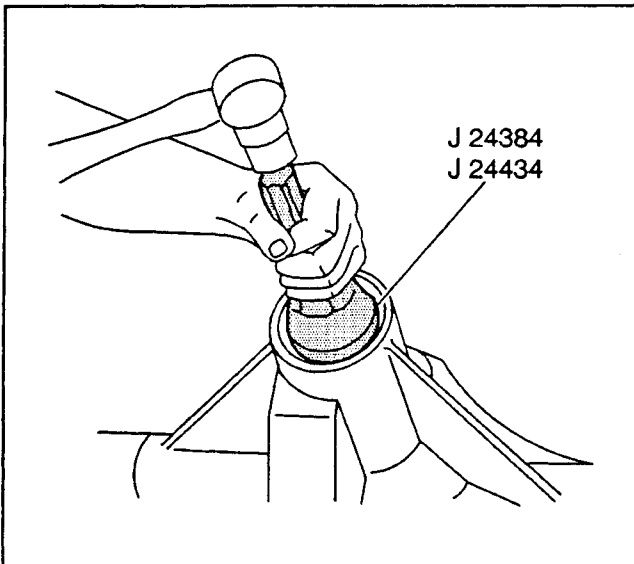

156490

### Installation Procedure

1. Lubricate the inside diameter of the new oil seal with extreme pressure lubricant such as P/N 9985038.
2. Install the oil seal into the bore using the *J 24384*.

**Important:** Do not coat the bearing.

3. Pack the cavity between the pinion stem, pinion flange and pinion nut with a non-hardening sealer such as Permatex® Type A or the equivalent.

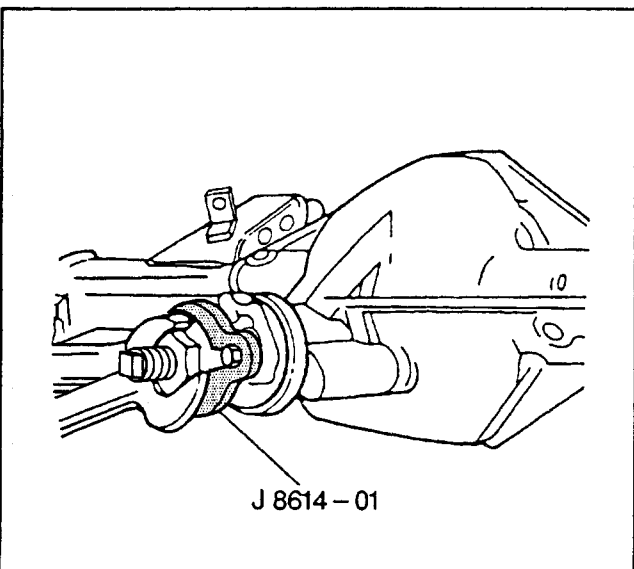

156437

4. Install the pinion flange using the *J 8614-01*. Use the alignment marks as a guide.

**Notice:** Refer to *Fastener Notice* in Cautions and Notices.

5. Install the pinion nut using the *J 8614-01*. Use the alignment marks as a guide.

### Tighten

Tighten the pinion nut to 597–678 N·m (440–550 lb ft).

6. Install the propeller shaft. Refer to *Propeller Shaft Replacement (One-Piece)* or *Two-Piece Propeller Shaft Replacement* or *Three-Piece Propeller Shaft Replacement* in Propeller Shaft.
7. Lower the vehicle.

## Hub and Drum Assembly Replacement (All Models)

### Removal Procedure

#### Tools Required

*J 2222-C* Wheel Bearing Nut Wrench

1. Raise the vehicle until the wheel is free to rotate.
2. Remove the wheel and tire.
3. Remove the axle shaft (5). Refer to *Axle Shaft Replacement (All Models)*.
4. Remove the retaining ring (10).
5. Remove the wheel bearing adjusting nut key (9).

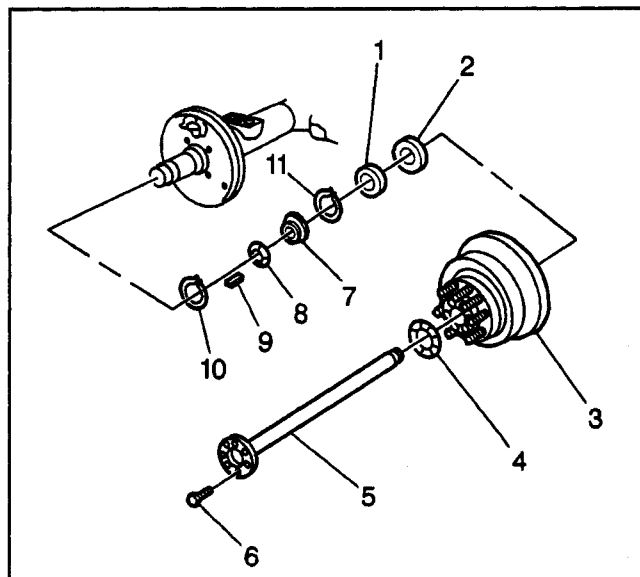

160066

6. Remove the adjusting nut using the *J 2222-C*.

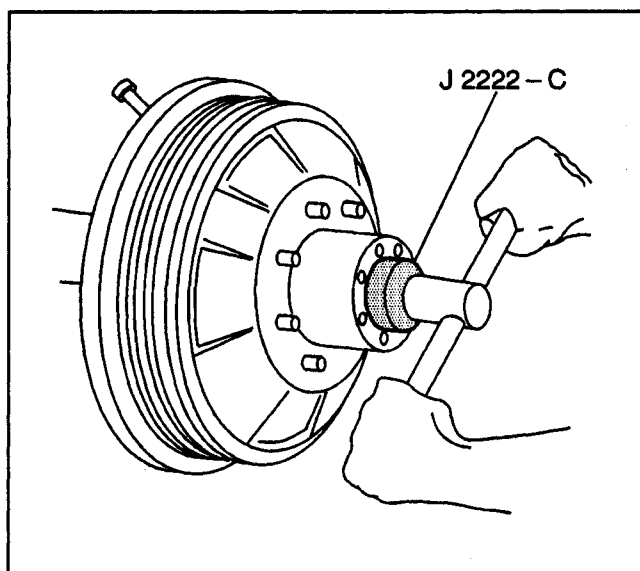

156458

7. Remove the hub and drum (3).
8. Inspect all the parts. Replace any parts as necessary.

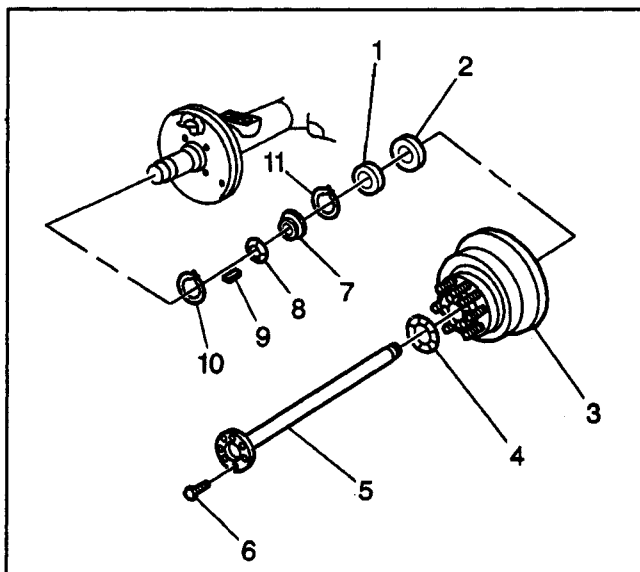

160066

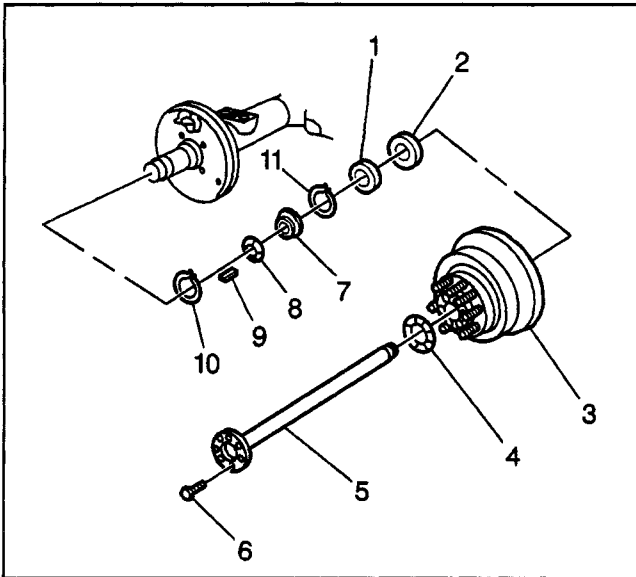

160066

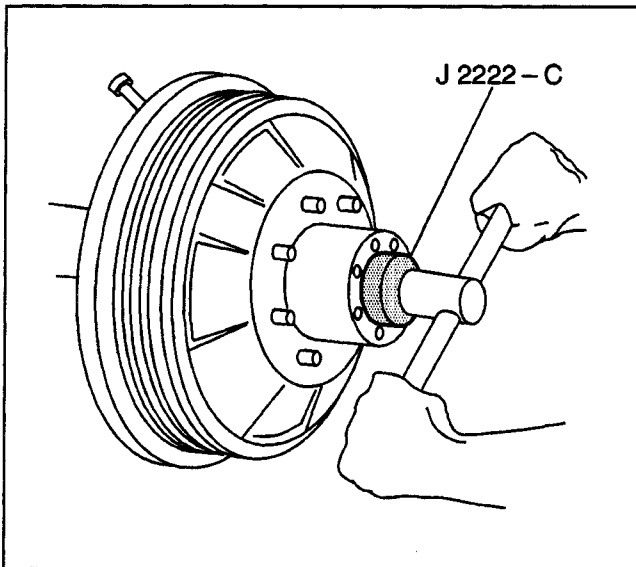

156458

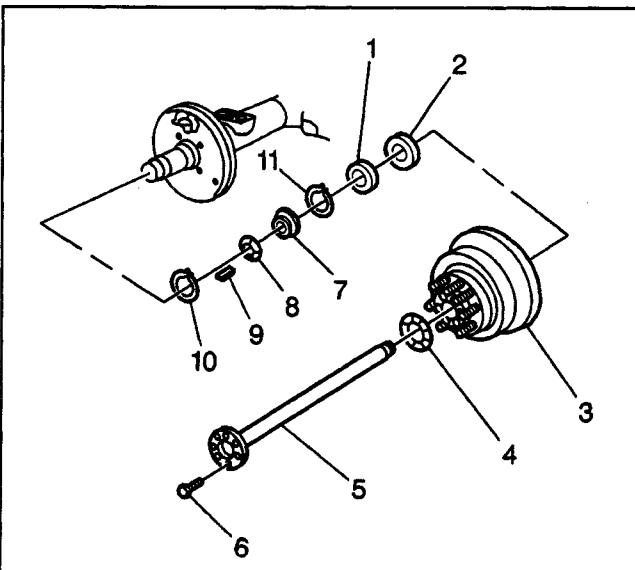

160066

### Installation Procedure

1. Install the hub and drum (3) to the axle tube.
  - Be sure the bearings and the oil seal are positioned properly.
  - Apply a light coat of high melting point EP bearing lubricant to the contact surfaces and the outside of the axle tube.
2. Install the wheel bearing adjusting nut key (9) into the key way.

**Notice:** Refer to *Fastener Notice* in Cautions and Notices.

3. Install the adjusting nut using the *J 2222-C*.
4. Adjust the bearing preload. Refer to *Wheel Bearing Adjustment (Drum Brakes)*.

5. Install the key (9).
6. Install the retaining ring (10).
7. Install the axle shaft (5). Refer to *Axle Shaft Replacement (All Models)*.
8. Install the wheel and tire.
9. Lower the vehicle.

## Hub and Rotor Assembly Replacement

### Removal Procedure

#### Tools Required

- J 8092 Wheel Bearing Nut Wrench
  - Wheel Bearing Nut Wrench J 42855 Wheel Bearing Nut Wrench
1. Raise the vehicle until the wheel is free to rotate.
  2. Remove the wheel and tire assembly. Refer to *Tire and Wheel Removal and Installation*.
  3. Remove the axle shaft. Refer to *Axle Shaft Replacement (All Models)*.
  4. Remove the outer locknut.
  5. Remove the lockwasher (if equipped).
  6. Remove the adjusting nut (using the J 2222-C for American Axle equipped vehicles, or *Wheel Bearing Nut Wrench J 42855* for Dana Axle equipped vehicles).
  7. Remove the washer (if equipped).
  8. Remove the hub and rotor.
  9. Inspect for any worn or damaged parts. Replace the parts as necessary.

### Installation Procedure

1. Install the hub and rotor assembly on the axle tube.
  - Be sure the bearings and the oil seal are positioned properly.
  - Apply a light coat of high melting point EP bearing lubricant to the contact surfaces and the outside of the axle tube.
2. Install the washer (if equipped).
3. Place the tang in the keyway (if equipped).
4. Install the adjusting nut (using the J 2222-C for American Axle equipped vehicles, or J 42855 for Dana Axle equipped vehicles).
5. Adjust the bearing preload. Refer to *Wheel Bearing Adjustment (Disc Brakes)*.
6. Install the lockwasher (if equipped).
7. Bend the tang of the washer (if equipped) to the flat of the adjusting nut.
8. Install the outer locknut.
9. Install the axle shaft. Refer to *Axle Shaft Replacement (All Models)*.
10. Install the wheel and tire assembly. Refer to *Tire and Wheel Removal and Installation*.
11. Lower the vehicle.

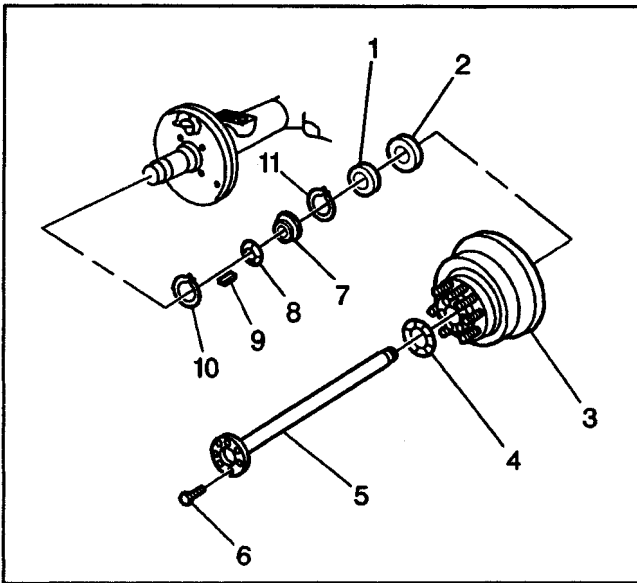

160066

## Bearing Cup Replacement (Drum)

### Removal Procedure

#### Tools Required

- J 8092 Driver Handle
- J 8608 Pinion Bearing Cup Installer
- J 24426 Outer Bearing Cup Installer
- J 24427 Inner Wheel Bearing Cup Installer
- J 39114-A Axle Shaft Seal Installer

1. Raise the vehicle until the wheels are free to rotate.
2. Remove the axle shaft (5). Refer to *Axle Shaft Replacement (All Models)*.
3. Remove the hub and drum. Refer to *Hub and Drum Assembly Replacement (All Models)*.
4. Remove the oil seal (2).
5. Use a drift to remove the inner bearing and the cup (1).
6. Use snap ring pliers to remove the retaining ring (11).
7. Remove the outer bearing ring using J 24426 and J 8092.

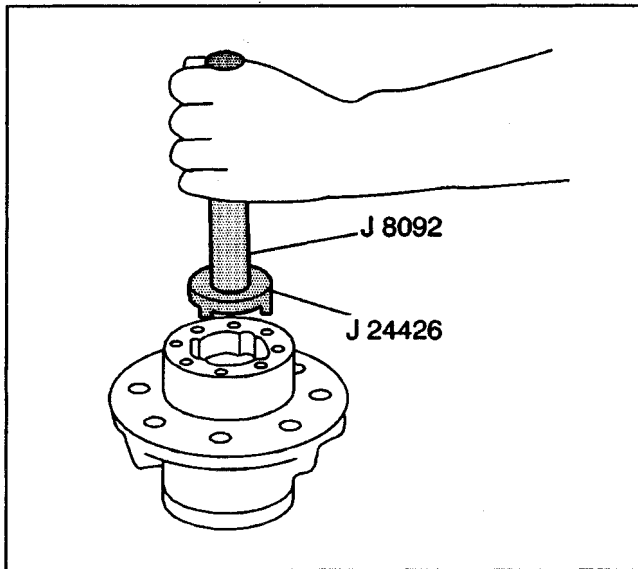

156462

8. Drive the bearing and the cup (14) from the hub (3).
9. Clean the old oil sealing compound from the oil seal bore in the hub.
10. Clean the bearing assemblies in a solvent using a stiff brush in order to remove the old lubricant.
  - Dry the bearings with compressed air.
  - Do not spin the bearings.
11. Clean the lubricant from the axle housing and from the inside of the hub.
12. Remove the gasket material from the hub and the axle shaft.
13. Inspect the bearings for wear, chipped edges or other damage.
14. Check for flat or rough spots on the rollers.
15. Inspect the cups for pits and cracks.
16. Replace parts as necessary.

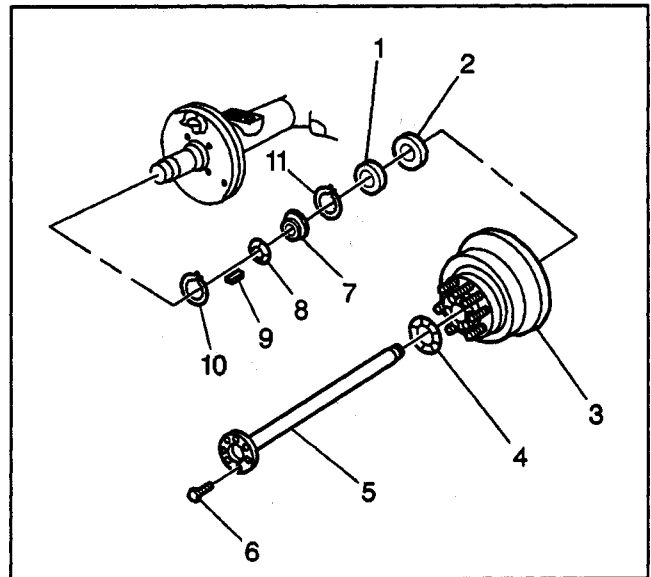

160066

**Installation Procedure**

1. Install the outer bearing cup (7) into the hub (3).

**Important:** Install the *J 8608* upside down on the *J 8092* so that the chamfer does not contact the bearing cup.

2. Drive the outer bearing cup (7) into the hub (3) using the *J 8608* and the *J 8092*.
3. Drive the outer bearing cup (7) beyond the retaining ring groove.
4. Install the retaining ring (11) in the groove.
5. Drive the outer bearing cup (7) onto the retaining ring (11) using the *J 24426*.

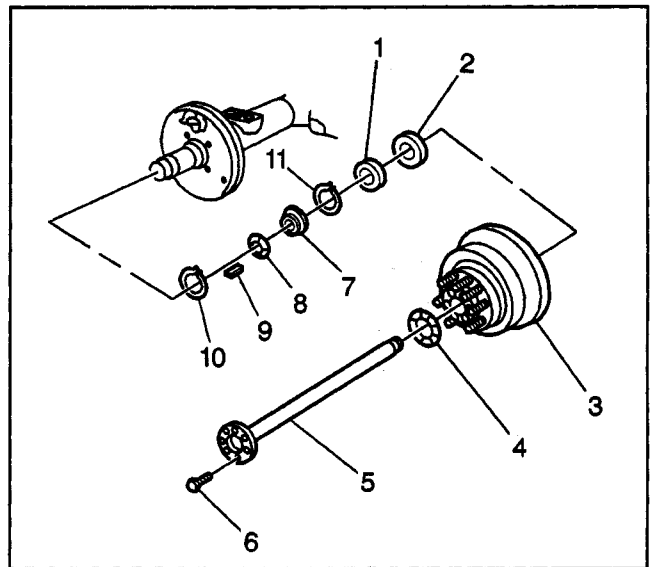

160066

6. Install the inner bearing cup using the *J 24427* and the *J 8092*.

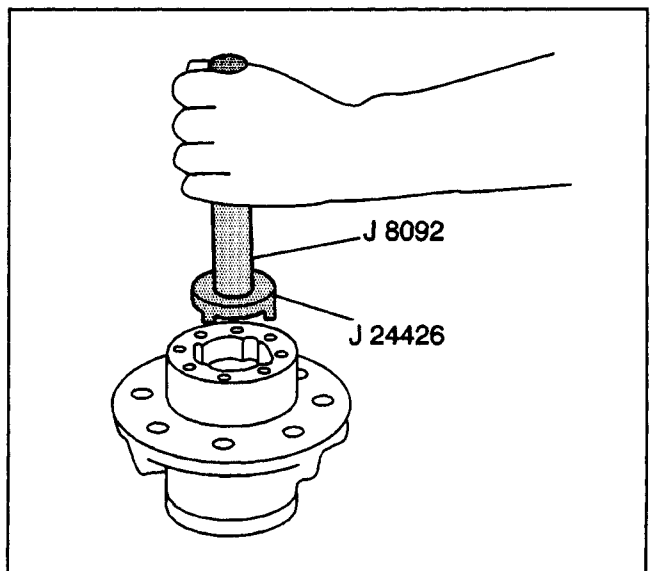

156462

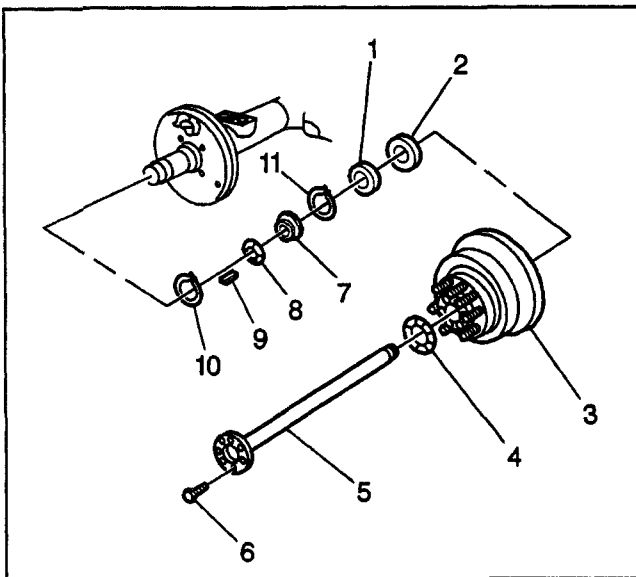

160066

7. Drive the inner bearing cup (1) until it is seated against the hub shoulder.
8. Install the inner bearing.
9. Install a new oil seal (2) using the *J 8092* and the *J 39114-A*.
10. Install the hub and drum assembly (3). Refer to *Hub and Drum Assembly Replacement (All Models)*.
11. Install the wheel bearing adjusting nut (8).
12. Adjust the bearing preload. Refer to *Wheel Bearing Adjustment (Drum Brakes)*.
13. Install the axle shaft (5). Refer to *Axle Shaft Replacement (All Models)*.
14. Lower the vehicle.

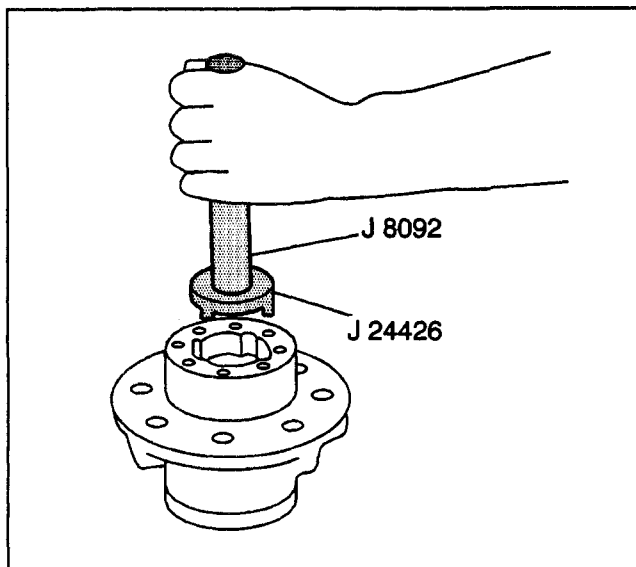

156462

## Bearing Cup Replacement (Disc)

### Removal Procedure

#### Tools Required

- *J 8092* Drive Handle
- *J 8608* Outer Pinion Bearing Cup Installer
- *J 24426* Outer Wheel Bearing Cup Installer
- *J 24427* Inner Wheel Cup Bearing Installer
- *J 39114-A* Axle Shaft Seal Installer

1. Raise the vehicle until the wheels are free to rotate.
2. Remove the axle shaft. Refer to *Axle Shaft Replacement (All Models)*.
3. Remove the hub and rotor assembly. Refer to or *Hub and Rotor Assembly Replacement*.
4. Remove the inner bearing and the oil seal.
  - Lay the drum on a flat surface using a shop towel in order to catch the bearing and the seal.
  - Use a drift to remove the bearing cup and the seal.
5. Remove the retaining ring using snap ring pliers.
6. Remove the outer bearing using the *J 8092* with the *J 24426*.
7. Drive the bearing and the cup from the hub.
8. Clean the old sealing compound from the oil seal bore in the hub.
9. Clean the bearing assemblies in a solvent using a stiff brush to remove the old lubricant.
10. Dry the bearings with compressed air. Do not spin the bearings.
11. Clean the lubricant from the axle tube and from inside the hub.
12. Clean the gasket material, if used, from the hub and the axle shaft.

13. Inspect the bearings for any wear, chipped edges or other damage. Refer to *Noise Diagnosis (Wheel Bearing)*.
14. Check for any flat or rough spots on the rollers.
15. Check the cups for any pits or cracks.
16. Replace and discard the old oil seal.
17. Pack the inner and the outer bearing with wheel bearing lubricant P/N 1051344. Refer to *Fluid and Lubricant Recommendations*.

### Installation Procedure

1. Install the outer bearing cup into the hub.

**Important:** Install the *J 8608* upside down on the *J 8092* so that the chamfer does not contact the bearing cup.

2. Drive the outer bearing cup into the hub using the *J 8608* and the *J 8092*. Drive the cup beyond the retaining ring groove.
3. Install the retaining ring into the groove.

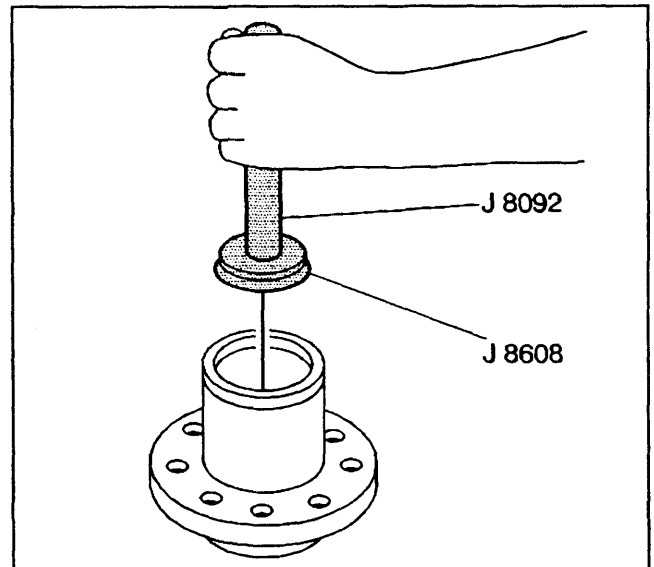

33875

4. Drive the cup back onto the retaining ring using the *J 24426* with the *J 8092*.

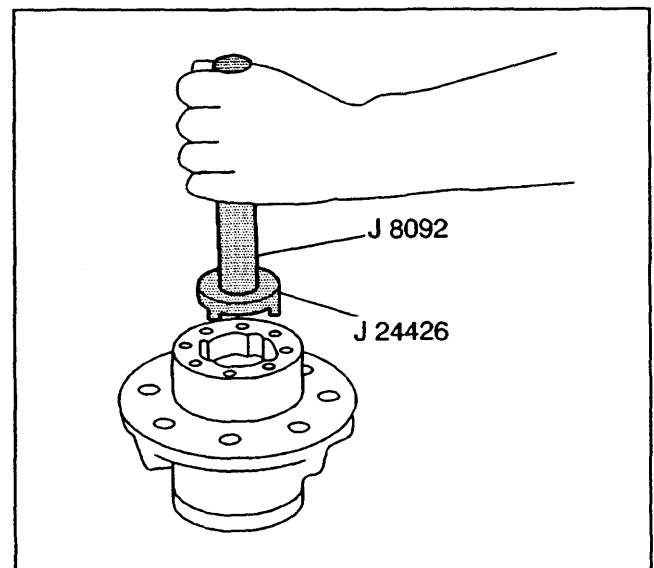

156462



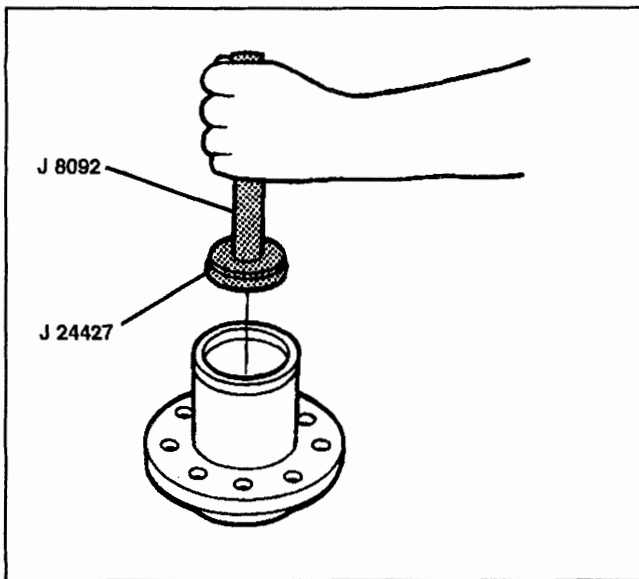

33870

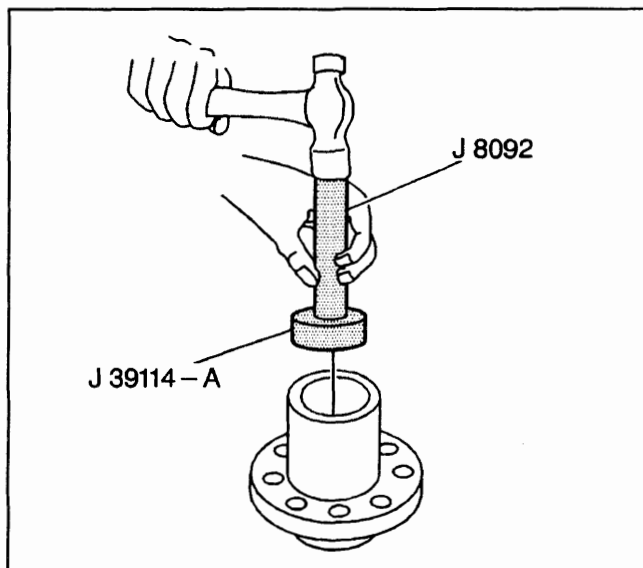

156477

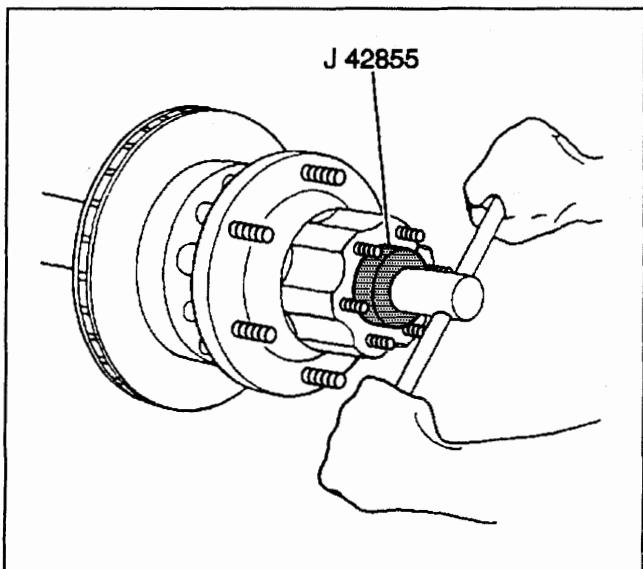

370611

5. Install the inner bearing cup using the *J 24426* and the *J 8092* until the cup is seated against the hub shoulder.
6. Install the inner bearing.
7. Install the outer bearing.

8. Install the new oil seal using the *J 8092* and the *J 39114-A*.
9. Install the hub and drum or the hub and rotor. Refer to *Hub and Rotor Assembly Replacement*.
10. Install the outer bearing.
11. Adjust the bearing preload. Refer to *Wheel Bearing Adjustment (Disc Brakes)*.
12. Install the axle shaft. Refer to *Axle Shaft Replacement (All Models)*.
13. Lower the vehicle.

## Wheel Bearing Adjustment (Disc Brakes)

### Diagnostic Procedure

1. Make sure the brakes are fully released and do not drag.
2. Pull or push the tire at the top back and forth in order to check the wheel bearing play.
  - Use a pry bar under the tire as an alternative.
  - If the wheel bearing adjustment is correct, movement of the brake drum in relation to the brake backing plate will be barely noticeable.
  - If the movement of the brake drum in relation to the brake backing plate is excessive, adjust the bearings.

## Removal Procedure

### Tools Required

- J 2222-C Wheel Bearing Nut Wrench
- Wheel Bearing Nut Wrench J 42855 Wheel Bearing Nut Wrench

1. Raise the vehicle until the wheel is free to spin.
2. Remove the axle shaft. Refer to *Axle Shaft Replacement (All Models)*.
3. Remove the outer locknut.
4. Disengage the lock washer from the adjusting nut.
5. Remove the lock washer.
6. Adjust the adjusting nut.
  - 6.1. Make sure the bearing cones are seated and in contact with the spindle shoulder.

**Notice:** Refer to *Fastener Notice* in Cautions and Notices.

- 6.2. Tighten the adjusting nut (using J 2222-C for American Axle equipped vehicles, or *Wheel Bearing Nut Wrench J 42855* for Dana Axle equipped vehicles) while rotating the hub assembly.

#### Tighten

Tighten the adjusting nut to 68 N·m (50 lb ft).

- 6.3. Back off the adjusting nut. Retighten the adjusting nut while rotating the hub.

#### Tighten

Tighten the adjusting nut to 47 N·m (35 lb ft).

- 6.4. Back off the adjusting nut 135–150 degrees.

## Installation Procedure

1. Install the lock washer.
2. Bend one tang of the lock washer a minimum of 30 degrees over a flat of the adjusting nut.

**Notice:** Refer to *Fastener Notice* in Cautions and Notices.

3. Install the outer locknut

#### Tighten

Tighten the outer locknut to 88 N·m (65 lb ft).

4. Set the bearing adjustment to 0.025–0.25 mm (0.001–0.01 in).
5. Bend one tang of the lock washer a minimum of 60 degrees over a flat of the outer locknut.
6. Apply the wheel bearing grease into the bearings.
7. Install the axle shaft. Refer to *Axle Shaft Replacement (All Models)*.
8. Lower the vehicle.

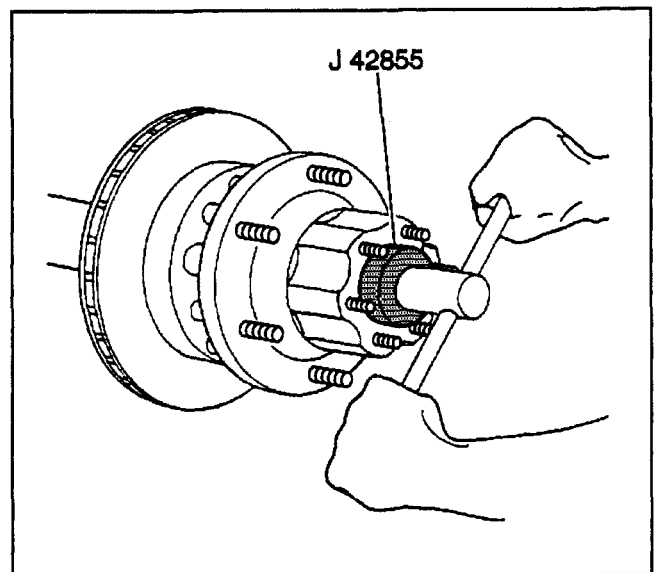

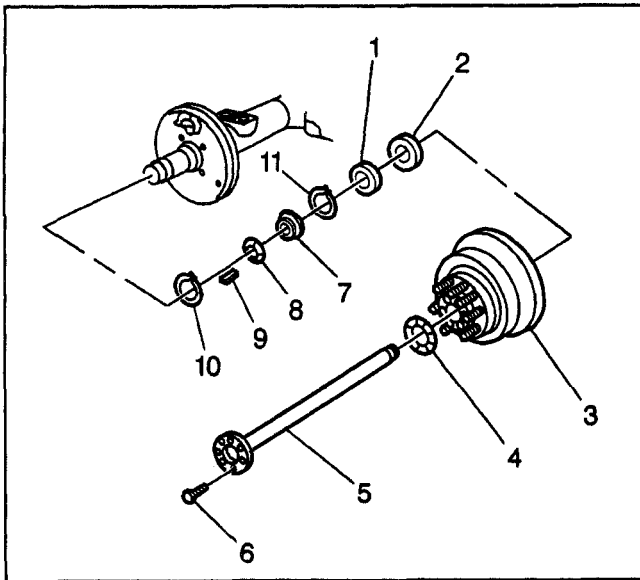

160066

## Wheel Bearing Adjustment (Drum Brakes)

### Diagnostic Procedure

1. Make sure the brakes are fully released and do not drag.
2. Pull or push the tire at the top back and forth in order to check the wheel bearing play.
  - Use a pry bar under the tire as an alternative.
  - If the wheel bearing adjustment is correct, movement of the brake drum in relation to the brake backing plate will be barely noticeable.
  - If the movement of the brake drum in relation to the brake backing plate is excessive, adjust the bearings.

### Removal Procedure

#### Tools Required

J 2222-C Wheel Bearing Nut Wrench

1. Raise the vehicle until the wheel is free to spin.
2. Remove the axle shaft (5). Refer to *Axle Shaft Replacement (All Models)*.
3. Be sure these are free of chips, burrs and shavings:
  - Keyway
  - Threads
  - Adjusting nut (8)
4. Remove the retaining ring (10).
5. Remove the wheel bearing adjusting key (9).
6. Make sure the bearings are seated and in contact with the spindle shoulder.

**Notice:** Refer to *Fastener Notice* in Cautions and Notices.

7. Tighten the wheel bearing adjusting nut using the J 2222-C.

#### Tighten

Tighten the adjusting nut to 68 N·m (50 lb ft).

8. Adjust the adjusting nut as follows:
  - 8.1. Back off the adjusting nut until the adjusting nut is just loose, but not more than one slot of the lock or the axle spindle.
  - 8.2. Align the closest adjusting nut slot with the keyway in the axle spindle.

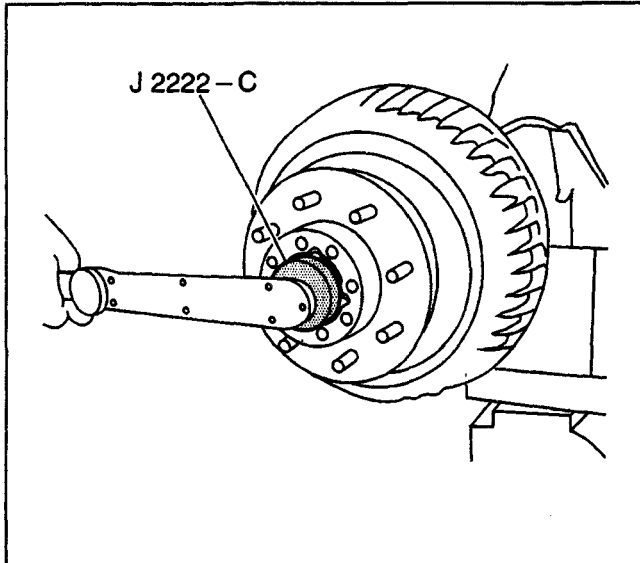

156468

**Installation Procedure**

1. Install the wheel bearing adjusting key (9) into the keyway and adjusting nut slot.
2. Install the retaining ring (10). Make sure the retaining ring is seated.
3. Install the axle shaft (5). Refer to *Axle Shaft Replacement (All Models)*.

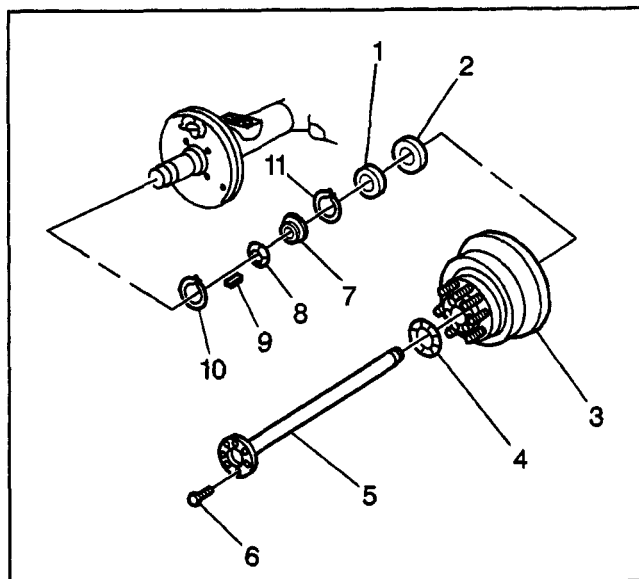

160066

## Description and Operation

### Rear Axle Description

P model trucks use various rear axles. These axles can be identified by ring gear size in inches, by manufacturer (American Axle and Dana), and by the type of axle shaft used (semi-floating or full-floating). American Axle supplies the 10½ inch ring gear, while Dana supplies the 11 inch ring gear.

### Axle Identification

In order to find the axle ratio for the vehicle, refer to *Label - Service Parts ID* Location of the label on P models is determined by the body builder.

### Rear Axle Operation

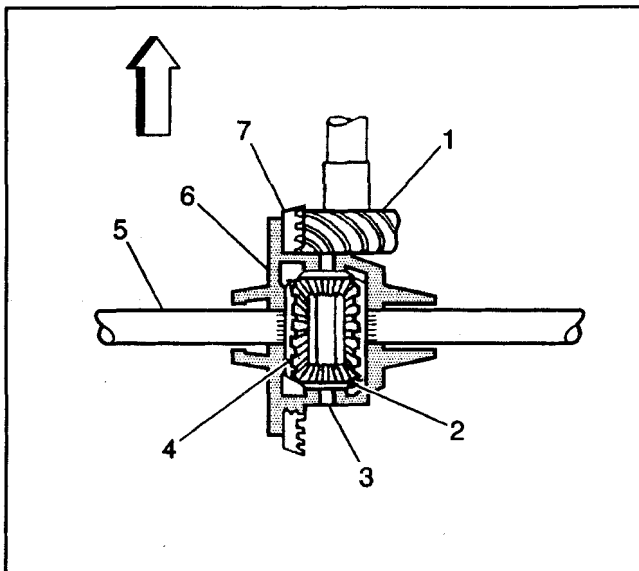

177270

A basic differential has a set of four gears consisting of two side gears (4) and two pinion gears (2). Each side gear splines to an axle shaft (5). Therefore, each axle shaft must turn when the side gear rotates.

The pinion gears mount on the pinion shaft (3). The pinion gears are free to rotate on the pinion shaft. The pinion shaft fits into a bore in the differential case (6). The pinion shaft is at right angles to the axle shafts.

Torque moves through the differential as follows:

1. The drive pinion gear (1) rotates the ring gear (7).
2. The ring gear, being bolted to the differential case, rotates the case.
3. The differential pinion, as it rotates with the case, forces the pinion gears against the side gears.

When both wheels have equal traction, the pinion gears do not rotate on the pinion shaft because the input force on the pinion gear divides equally between the two side gears. Therefore, the pinion gears revolve with the pinion shaft, but the pinion gears do not rotate around the shaft itself. The side gears, being splined to the axle shafts and in mesh with the pinion gears, rotate the axle shafts.

If a vehicle were always driven in a straight line, the ring and pinion gears would be sufficient. The axle shaft could then be solidly attached to the ring gear and both driving wheels would turn at equal speed.

However, when turning a corner, the tires would scuff and slide, because the outside wheel would travel farther than the inside wheel. In order to prevent tire scuffing and sliding, the differential allows the axle shafts to rotate at different speeds.

When the vehicle turns a corner, the inner wheel turns more slowly than the outer wheel and slows its axle side gear, since the axle shaft is splined to the side gear. The axle pinion gears will roll around the slowed axle side gear, driving the other axle side gear and wheel faster.

Special Tools and Equipment

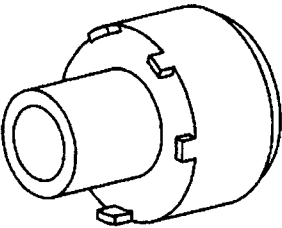
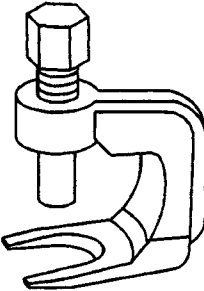
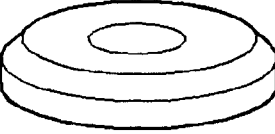

Illustration	Tool Number/ Description
 <p data-bbox="388 561 440 582">36476</p>	<p data-bbox="464 381 749 443">J 2222-C Wheel Bearing Nut Wrench</p>
 <p data-bbox="388 907 440 928">153085</p>	<p data-bbox="495 733 722 795">J 6627-A Wheel Stud Remover</p>
 <p data-bbox="401 1259 440 1280">5332</p>	<p data-bbox="495 1071 718 1154">J 8608 Outer Pinion Bearing Installer</p>
 <p data-bbox="401 1607 440 1628">2015</p>	<p data-bbox="534 1431 680 1493">J 8092 Driver Handle</p>

Illustration	Tool Number/ Description
 <p data-bbox="1099 561 1138 582">1507</p>	<p data-bbox="1169 368 1447 451">J 8614-01 Pinion Flange Holder And Remover</p>
 <p data-bbox="1091 907 1138 928">36473</p>	<p data-bbox="1185 733 1436 795">J 24384 Pinion Oil Seal Installer</p>
 <p data-bbox="1091 1259 1138 1280">36475</p>	<p data-bbox="1169 1071 1447 1154">J 24426 Outer Wheel Bearing Cup Installer</p>
 <p data-bbox="1091 1607 1138 1628">36474</p>	<p data-bbox="1169 1421 1447 1504">J 24427 Inner Wheel Bearing Cup Installer</p>

Illustration	Tool Number/ Description
 <p data-bbox="382 499 429 520">36472</p>	<p data-bbox="471 317 730 379">J 39114-A Axle Shaft Seal Installer</p>
 <p data-bbox="377 851 429 872">156470</p>	<p data-bbox="498 671 702 733">J 2222-C Wheel Bearing Nut</p>
 <p data-bbox="377 1199 429 1220">156497</p>	<p data-bbox="514 1021 683 1083">J 5853-B Torque Wrench</p>
 <p data-bbox="398 1549 429 1570">130</p>	<p data-bbox="482 1369 711 1431">J 6627-A Wheel Stud Remover</p>
 <p data-bbox="370 1897 429 1918">156502</p>	<p data-bbox="451 1707 733 1790">J 21128 Axle Shaft and Pinion Seal Installer</p>

Illustration	Tool Number/ Description
 <p data-bbox="1075 499 1135 520">156498</p>	<p data-bbox="1197 317 1408 379">J 22349 Pinion Cup Installer</p>
 <p data-bbox="1091 851 1135 872">5327</p>	<p data-bbox="1193 671 1408 733">J 22388 Pinion Seal Installer</p>
 <p data-bbox="1075 1199 1135 1220">156541</p>	<p data-bbox="1177 1021 1423 1083">J 22804-1 Pinion Oil Seal Spacer</p>
 <p data-bbox="1075 1549 1135 1570">156544</p>	<p data-bbox="1188 1369 1408 1431">J 22836 Pinion Seal Installer</p>
 <p data-bbox="1075 1897 1135 1918">156500</p>	<p data-bbox="1141 1707 1448 1790">J 23689 Axle Shaft Bearing Remover</p>

Illustration	Tool Number/ Description
 <p>156531</p>	<p>J 29709 Axle Shaft Bearing Installer</p>
 <p>156545</p>	<p>J 29712 Axle Shaft Bearing Remover</p>
 <p>156537</p>	<p>J 29713 Axle Shaft Bearing Installer</p>

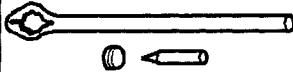
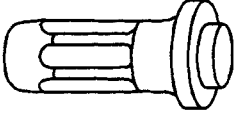
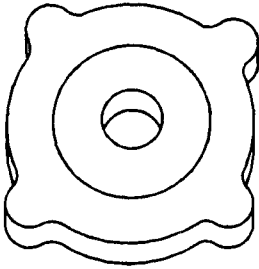
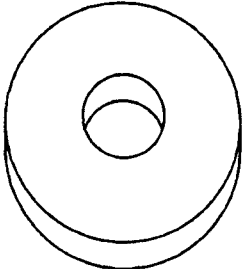

## Section 4

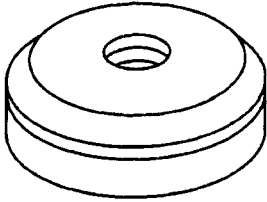
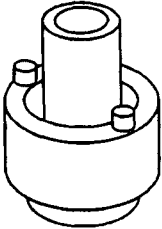
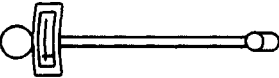
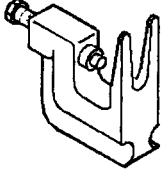
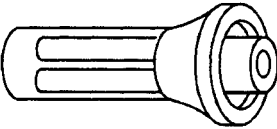
# Driveline/Axle

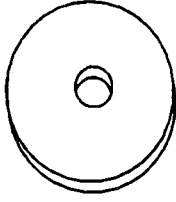
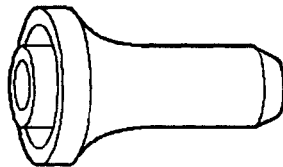
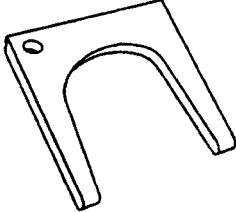
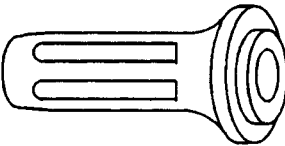
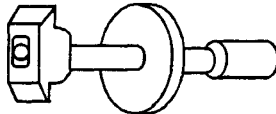
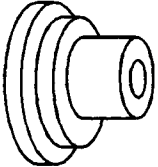
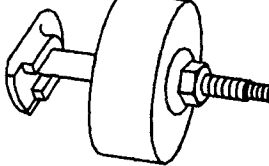
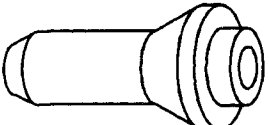
<b>Rear Drive Axle</b> .....	(S1) 4-3	Rear Axle Housing Cover and Gasket Replacement (American Axle 10 1/2 and 11 1/2 Inch) .....	(S1) 4-29
<b>Specifications</b> .....	(S1) 4-3	Axle Housing Replacement (American Axle 10 1/2 and 11 1/2 Inch) .....	(S1) 4-31
Fastener Tightening Specifications (American Axle 11 1/2 Inch) .....	(S1) 4-3	Pinion Bearings Replacement (American Axle 10 1/2 Inch) .....	(S1) 4-33
Fastener Tightening Specifications (Spicer Dana S135 and S150 14 Inch) .....	(S1) 4-3	Pinion Bearings Replacement (American Axle 11 1/2 Inch) .....	(S1) 4-36
Lubrication Specifications .....	(S1) 4-3	Pinion Bearings Replacement (Spicer Dana S135 and S150 14 Inch) ....	(S1) 4-39
<b>Component Locator</b> .....	(S1) 4-4	Pinion and Ring Gear Replacement (American Axle 11 1/2 Inch) .....	(S1) 4-44
Rear Axle Disassembled Views .....	(S1) 4-4	Pinion and Ring Gear Replacement (Spicer Dana S135 and S150 14 Inch) .....	(S1) 4-47
<b>Diagnostic Information and   Procedures</b> .....	(S1) 4-6	Pinion Depth Adjustment (American Axle 11 1/2 Inch) .....	(S1) 4-52
Ring Gear and Pinion Tooth Contact Pattern (Spicer Dana S135 and S150 14 Inch) .....	(S1) 4-6	Differential Replacement (American Axle 10 1/2 and 11 1/2 Inch) .....	(S1) 4-54
Gear Tooth Nomenclature .....	(S1) 4-6	Differential Replacement (Spicer Dana S135 and S150 14 Inch) .....	(S1) 4-57
Gear Tooth Contact Pattern Check Procedure .....	(S1) 4-6	Differential Carrier Replacement (Spicer Dana S135 and S150 14 Inch) ....	(S1) 4-60
Correct Gear Patterns For Gleason Cut Gears .....	(S1) 4-6	Differential Overhaul (American Axle 10 1/2 and 11 1/2 Inch) .....	(S1) 4-63
<b>Repair Instructions</b> .....	(S1) 4-8	Differential Overhaul (Spicer Dana S135 and S150 14 Inch) .....	(S1) 4-65
Lubricant Level Check (American Axle 11 1/2 Inch) .....	(S1) 4-8	Differential Side Bearing Preload Adjustment (American Axle 10 1/2 and 11 1/2 Inch) .....	(S1) 4-67
Lubricant Change (Spicer Dana S135 and S150 14 Inch) .....	(S1) 4-8	Backlash Adjustment (American Axle 10 1/2 and 11 1/2 Inch) .....	(S1) 4-70
Axle Shaft Replacement (American Axle 11 1/2 Inch) .....	(S1) 4-10	Backlash Adjustment (Spicer Dana S135 and S150 14 Inch) .....	(S1) 4-73
Axle Shaft Replacement (Spicer Dana S135 and S150 14 Inch) .....	(S1) 4-11	Gear Tooth Contact Pattern Check (American Axle 10 1/2 and 11 1/2 Inch) .....	(S1) 4-74
Pinion Yoke and Oil Seal Replacement (American Axle 11 1/2 Inch) .....	(S1) 4-14		
Pinion Yoke and Oil Seal Replacement (Spicer Dana S135 and S150 14 Inch) .....	(S1) 4-17		
Axle Disassemble (American Axle 11 1/2 Inch) .....	(S1) 4-19		
Axle Assemble (American Axle 11 1/2 Inch) .....	(S1) 4-25		

**(S1) 4-2 Table of Contents**

**Driveline/Axle**

Rear Hub and Bearing Replacement  
(Spicer Dana S135 and S150  
14 Inch) ..... (S1) 4-79

Axle Replacement  
(American Axle 11 1/2 Inch) ..... (S1) 4-81

Axle Replacement (Spicer Dana  
S135 and S150 14 Inch) ..... (S1) 4-83

Cleaning and Inspection ..... (S1) 4-85

**Description and Operation** ..... (S1) 4-88

Rear Axle Description ..... (S1) 4-88

Gear Set Identification  
(Spicer Dana S135 and S150  
14 Inch) ..... (S1) 4-88

**Special Tools and Equipment** ..... (S1) 4-89

## Rear Drive Axle

### Specifications

#### Fastener Tightening Specifications (American Axle 11 1/2 Inch)

Application	Specification	
	Metric	English
Axle Housing Cover	40 N·m	30 lb ft
Filler Plug	33 N·m	24 lb ft
Drain Plug	33 N·m	24 lb ft
Differential Adjusting Nut Lock Bolts	27 N·m	20 lb ft
Differential Side Bearing Cap Mounting Bolts	207 N·m	103 lb ft
Ring Gear Bolts	237 N·m	175 lb ft
Axle Shaft Flange Bolts	156 N·m	115 lb ft

#### Fastener Tightening Specifications (Spicer Dana S135 and S150 14 Inch)

Application	Specification	
	Metric	English
Carrier Mounting Bolts	163 N·m	120 lb ft
Pinion Nut	11,220 N·m	900 lb ft
Filler Plug	61 N·m	45 lb ft
Drain Plug	61 N·m	45 lb ft
Differential Adjusting Ring Lock Bolts	41 N·m	30 lb ft
Differential Case Bolts	163 N·m	120 lb ft
Differential Side Bearing Cap Mounting Bolts	183 N·m	135 lb ft
Differential Carrier to Rear Axle Housing Mounting Bolts	163 N·m	120 lb ft
Axle Shaft Flange Nuts	70 N·m	55 lb ft

### Lubrication Specifications

Application	Specification	
	Metric	English
American Axle 11 1/2 Inch	3.6 liters	7.3 pints
Spicer Dana S135 and S150 14 Inch	11.6 liters	24.5 pints

### Component Locator

### Rear Axle Disassembled Views

Spicer Dana S135 and S150 14 Inch Rear Axle Components

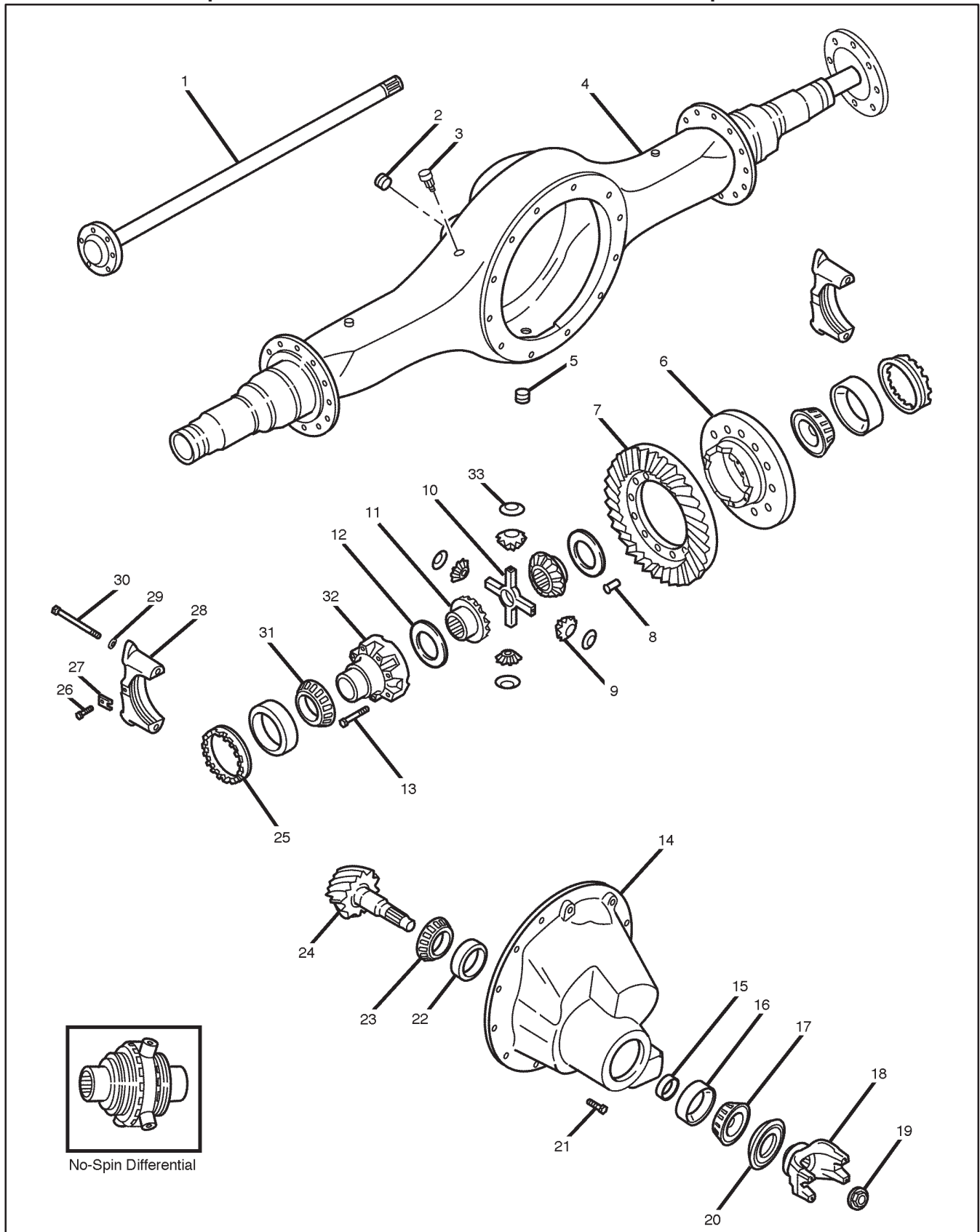

**Legend**

- |  |   |
|--|---|
| (1) Axle Shaft                         | (18) End Yoke Assembly                      |
| (2) Fill Plug                          | (19) Flange Hex Nut                         |
| (3) Vent Plug                          | (20) Pinion Oil Seal                        |
| (4) Housing                            | (21) Carrier Mounting Bolt                  |
| (5) Magnetic Drain Plug                | (22) Inner Pinion Bearing Cup               |
| (6) Differential Case Flange Half      | (23) Inner Pinion Bearing Cone              |
| (7) Ring Gear                          | (24) Pinion                                 |
| (8) Ring Gear Rivet                    | (25) Differential Bearing Adjusting Ring    |
| (9) Differential Pinion Mate           | (26) Adjusting Ring Lock Bolt               |
| (10) Differential Cross Shaft          | (27) Adjusting Ring Lock                    |
| (11) Differential Side Gear            | (28) Differential Bearing Cap               |
| (12) Differential Gear Thrust Washer   | (29) Differential Case Cap Washer           |
| (13) Differential Case Bolt            | (30) Differential Bearing Cap Bolt          |
| (14) Carrier Housing                   | (31) Differential Bearing Cone              |
| (15) Pinion Preload Spacer (Selective) | (32) Differential Case Cap Half             |
| (16) Outer Pinion Bearing Cup          | (33) Differential Pinion Mate Thrust Washer |
| (17) Outer Pinion Bearing Cone         |   |
-

## Diagnostic Information and Procedures

### Ring Gear and Pinion Tooth Contact Pattern (Spicer Dana S135 and S150 14 Inch)

The ring gear and pinion tooth contact pattern check is used to verify the correct position of the ring gear and pinion after the assembly of the carrier is complete. Gear sets, which are not positioned properly, may be noisy and have a short life span. A pattern check ensures that the best contact has been obtained between the ring gear and the pinion. This will ensure the system will produce low noise and have a long life.

**Important:** If a matched gear set is being reused, measure the backlash before disassembly and reassemble to the same backlash. This method will match the ring gear and pinion to their established wear patterns. The hand rolled patterns established during ring gear and pinion tooth contact pattern check will cover less area than the pattern established during actual service.

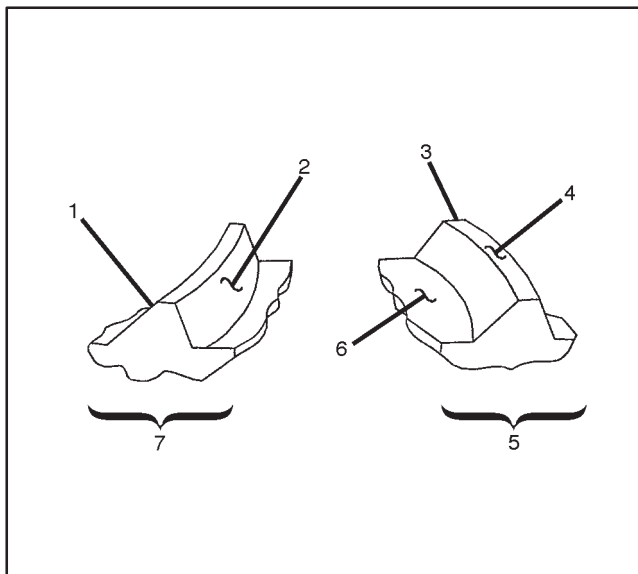

WRK42016

#### Legend

- (1) Heel
- (2) Profile
- (3) Toe
- (4) Top Land
- (5) Coast Side (Concave)
- (6) Root
- (7) Drive Side (Convex)

### Gear Tooth Nomenclature

The side of the ring gear tooth that curves outward, or is convex, is called the drive side of the tooth. The side of the ring gear tooth that curves inward, or is concave, is called the coast side of the tooth. The end of the tooth nearest the center of the ring gear is called the toe end of the tooth and the end that is farthest away from the center of the ring gear is called the heel end of the tooth.

### Gear Tooth Contact Pattern Check Procedure

1. Wipe the differential case, the ring gear, the pinion, and the carrier until they are free of lubricant. Carefully clean the lubricant off of each gear tooth.
2. Using a medium stiff brush apply gear marking compound, GM P/N 1052351 or equivalent, sparingly to 1/4 of the ring gear teeth.

**Important:** Performing a gear tooth contact pattern check without loading the gears will not produce a satisfactory result.

3. Apply a drag to the gear set until a torque load of 14 N·m (10 lb ft) is required to turn the pinion.
4. Using a wrench, rotate the pinion flange until the ring gear has turned one full revolution.
5. Turn the drive pinion flange in the opposite direction until the ring gear has turned one full revolution.
6. Observe the gear tooth contact pattern on the ring gear teeth and compare it to the following illustrations.

### Correct Gear Patterns For Gleason Cut Gears

If the pattern on the ring gear doesn't match one of the patterns shown in the illustrations, the gear tooth contact pattern on this axle model can be moved from heel to toe or toe to heel by adjusting the backlash between the gear teeth. The depth of the tooth contact pattern cannot be adjusted.

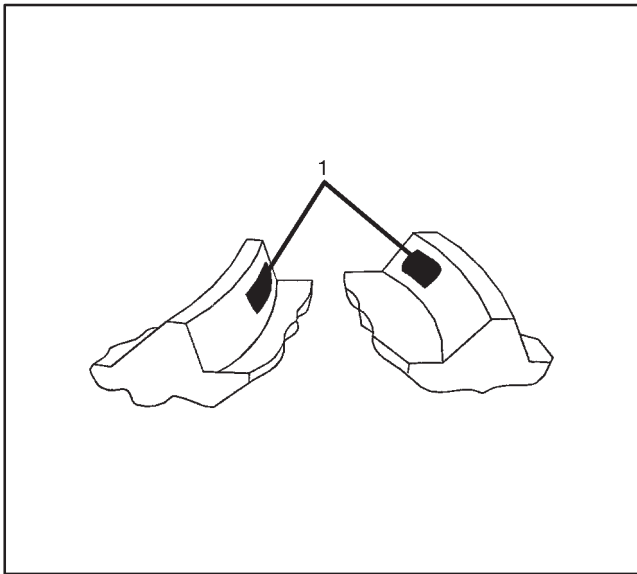

WRK42018

**Legend**

(1) Lightly Loaded Correct Gear Patterns

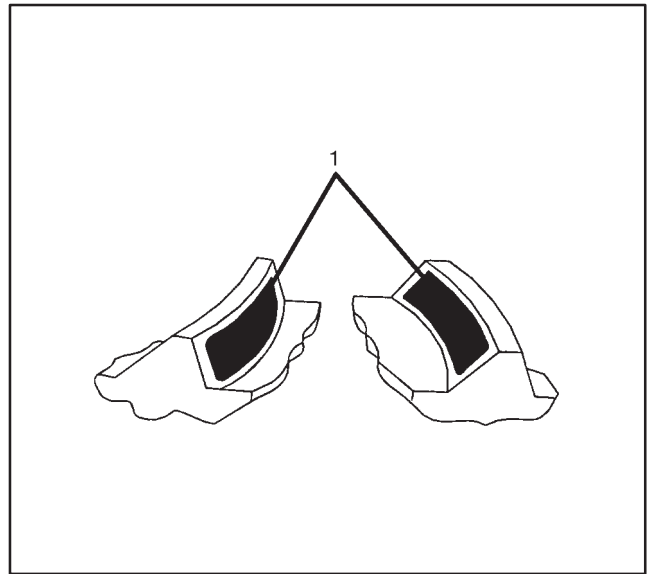

WRK42019

**Legend**

(1) Heavily Loaded Correct Gear Patterns

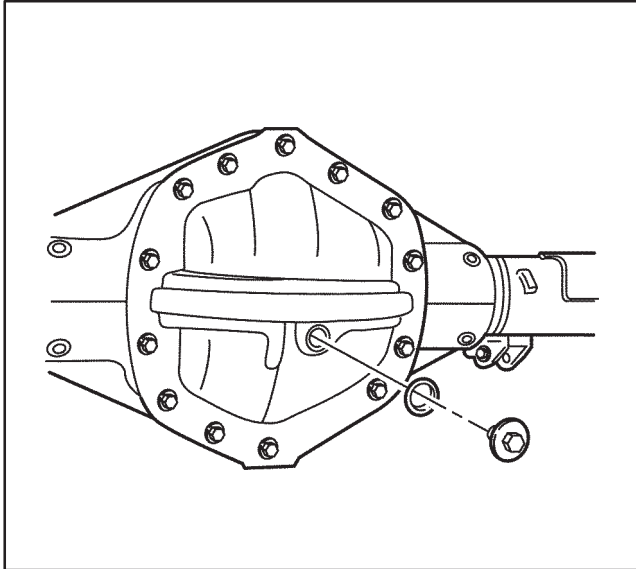

WRK42081

## Repair Instructions

### Lubricant Level Check (American Axle 11 1/2 Inch)

1. Raise the vehicle. Refer to *Lifting and Jacking the Vehicle* in the WCC Service Manual.
2. Make sure the vehicle is level.
3. Inspect the rear axle for leaks. Repair as necessary.
4. Clean the area around the rear axle fill plug.
5. Remove rear axle fill plug and the seal.
6. Inspect the lubricant level. The lubricant level should be between 0 – 10 mm (0 – 0.4 in) below the fill plug opening.
7. If the level is low, add lubricant until the level is even with the bottom edge of the fill plug opening. Use the proper fluid. Refer to *Fluid and Lubricant Recommendations* in this supplement.

**Notice:** Refer to *Fastener Notice* in Cautions and Notices in the WCC Service Manual.

8. Install the rear axle fill plug and gasket.

#### Tighten

Tighten the rear axle fill plug to 33 N · m (24 lb ft).

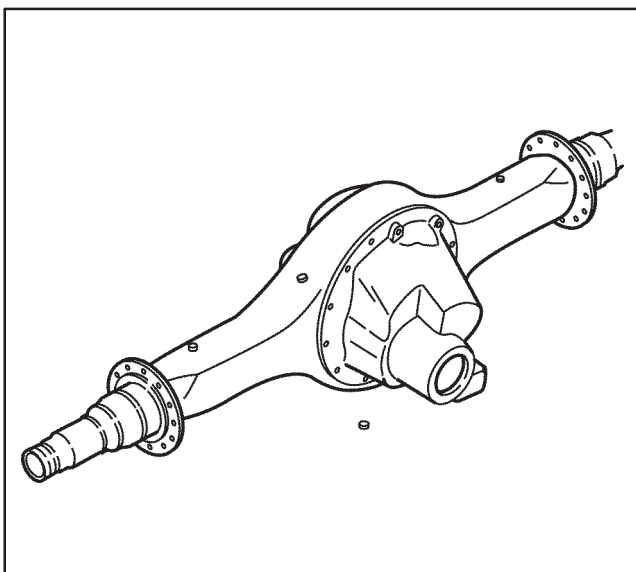

WRK42014

### Lubricant Change (Spicer Dana S135 and S150 14 Inch)

**Important:** In order to remove the maximum amount of foreign material and contaminants, always drain the rear axle lubricant when it is at its normal operating temperature.

#### Removal Procedure

1. Raise the vehicle. Refer to *Lifting and Jacking the Vehicle* in the WCC Service Manual.
2. Place a suitable container under the rear axle housing cover to catch draining lubricant.
3. Remove the rear axle drain plug and let the lubricant drain into the container.



### Installation Procedure

**Notice:** In all cases where wheel components are being installed, either new or after a maintenance activity, the rear wheel hub cavities are empty.

Rear wheel bearings and seals must be manually supplied with adequate rear axle lubricant or they will be severely damaged before normal motion of the vehicle can provide an adequate supply of lubricant. To avoid the risk of premature damage to the rear wheel bearings and hub seals, they must be filled with rear axle lubricant any time the wheel components are being installed.

**Notice:** Refer to *Fastener Notice* in Cautions and Notices in the WCC Service Manual.

1. Install the rear axle drain plug.

#### Tighten

Tighten the rear axle drain plug to 61 N·m (45 lb ft).

2. Remove the rear axle fill plug and seal.

**Important:** The rear axle must be level during filling and checking.

3. Fill the rear axle with the proper type and quantity of lubricant until the level is even with the bottom of the fill hole. Refer to *Lubrication Specifications* and *Fluid and Lubricant Recommendations* in this supplement.

**Important:** If any service has been performed at the rear wheels, perform steps 4 through 10 to fill the rear wheel hub cavities, otherwise proceed to step 11.

4. Install the rear axle fill plug and seal.

#### Tighten

Tighten the rear axle fill plug hand tight.

5. Raise the right side of the rear axle a minimum of 152.4 mm (6 in). Maintain this position for approximately one minute in order to allow the rear axle lubricant to flow into the left wheel hub cavity.
6. Lower the vehicle.
7. Raise the left side of the rear axle a minimum of 152.4 mm (6 in). Maintain this position for approximately one minute in order to allow the rear axle lubricant to flow into the right wheel hub cavity.
8. Return the vehicle to a level position.
9. Remove the rear axle fill plug and seal.

**Important:** The rear axle must be level during filling and checking.

10. Fill the rear axle with the proper type and quantity of lubricant until the level is even with the bottom of the fill hole. Refer to *Lubrication Specifications* and *Fluid and Lubricant Recommendations* in this supplement.

11. Install the rear axle fill plug and seal.

#### Tighten

Tighten the rear axle fill plug to 61 N·m (45 lb ft).

12. Lower the vehicle.

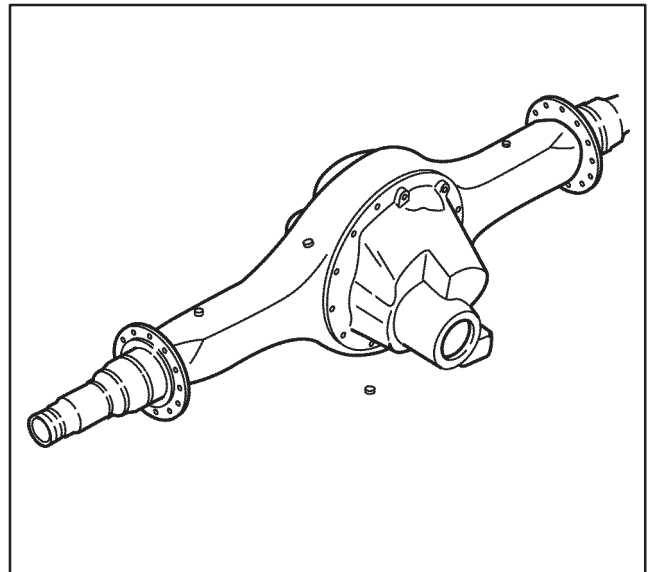

WRK42014

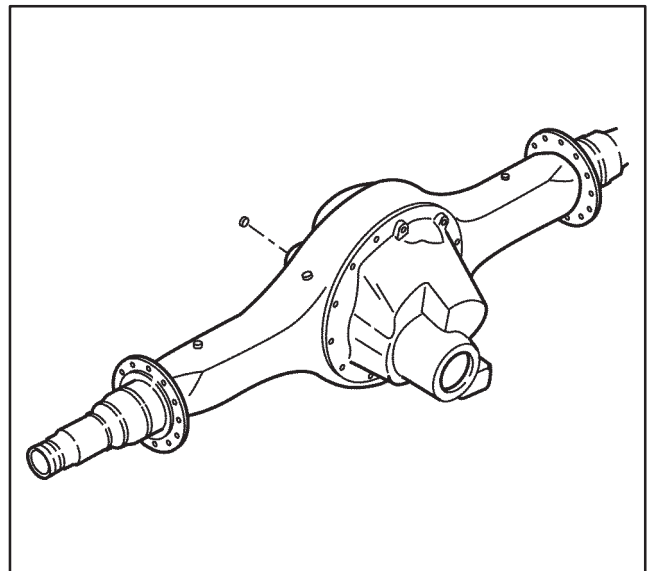

WRK42015

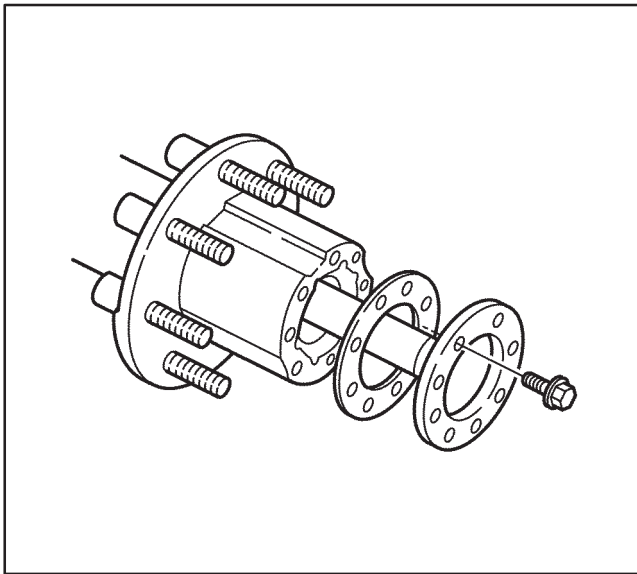

WRK42106

### Axle Shaft Replacement (American Axle 11 1/2 Inch)

#### Removal Procedure

1. Remove the axle shaft flange bolts.
2. Remove the rear axle shafts as follows:
  - 2.1. Lightly tap the axle shaft flange with a soft-faced hammer in order to loosen the shaft.
  - 2.2. Grip the rib on the axle shaft flange with locking pliers.
  - 2.3. Pull on the axle shaft using a twisting motion to free its splines from the differential side gears.
  - 2.4. Once the axle shaft is clear of the differential side gears, pull it straight out of the rear axle housing.
  - 2.5. Remove the other axle shaft in the same manner.
3. Remove the axle shaft flange gaskets.
4. Clean the mating surfaces on the axle shaft flanges and rear axle housing.

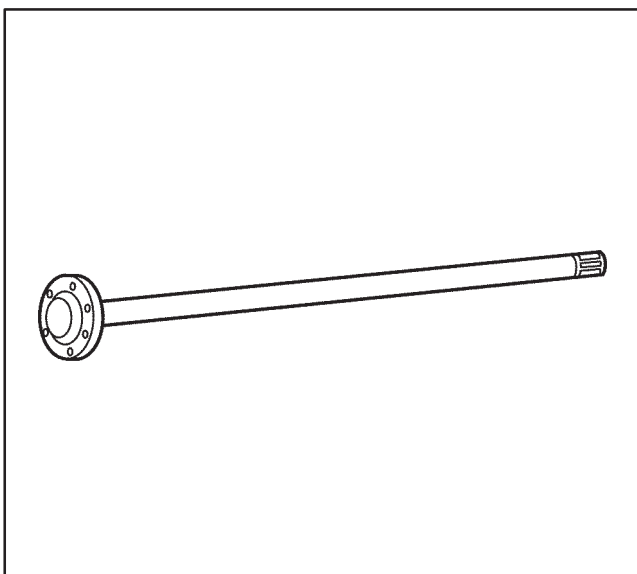

WRK42071

5. Inspect the axle shaft to see if it is bent.
6. Inspect the splines for chips, burns, cracking or excessive wear. Replace the axle shaft if any of those conditions exist.

**Installation Procedure**

1. Install a new gasket onto the axle shaft.
2. Install the axle shaft and gasket into the rear axle housing.

**Important:** Ensure that the axle shaft splines mesh into the differential side gear and that the holes in the axle shaft flange and gasket align with the holes in the hub.

**Notice:** Refer to *Fastener Notice* in Cautions and Notices in the WCC Service Manual.

3. Install the axle shaft bolts.

**Tighten**

Tighten the axle shaft bolts to 156 N·m (115 lb ft).

4. Check the lubricant level and adjust as necessary. Refer to *Lubricant Level Check (American Axle 11 1/2 Inch)* in this supplement.

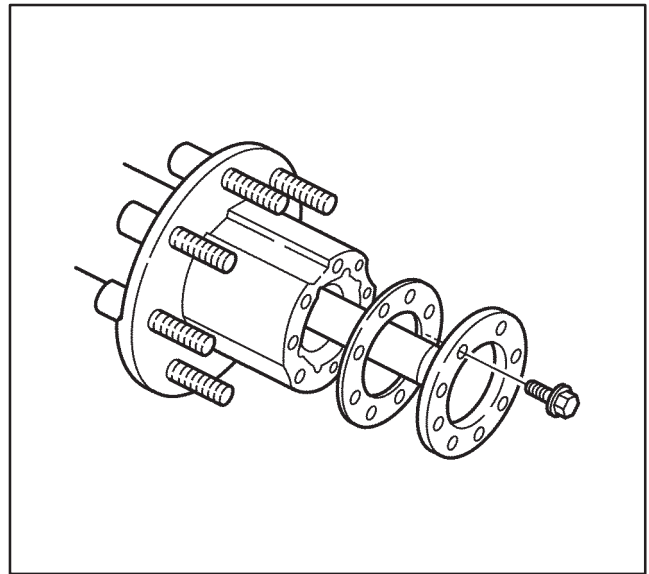

WRK42106

### Axle Shaft Replacement (Spicer Dana S135 and S150 14 Inch)

**Removal Procedure**

1. Remove the axle shaft flange stud nuts.

**Notice:** Do not strike the axle shaft flange directly with a hammer or attempt to use a chisel or wedge to loosen the axle shaft or split tapered dowels. This can cause damage to the axle shaft and wheel hub.

2. Remove the rear axle shafts as follows:
  - 2.1. Hold a 19 mm (3/4 in) diameter brass drift against the axle flange.
  - 2.1. Tap the drift with a soft-faced hammer in order to loosen the split tapered dowels.
  - 2.3. Remove the split tapered dowels.

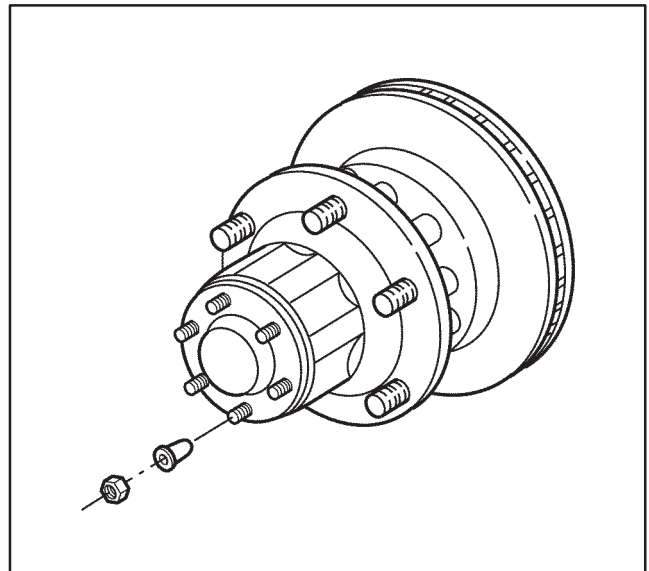

WRK42067

- 2.4. Pull on the axle shaft using a twisting motion to free its splines from the differential side gears.
- 2.5. Once the axle shaft is clear of the differential side gears, pull it straight out of the rear axle housing.
- 2.6. Remove the other axle shaft in the same manner, if necessary.

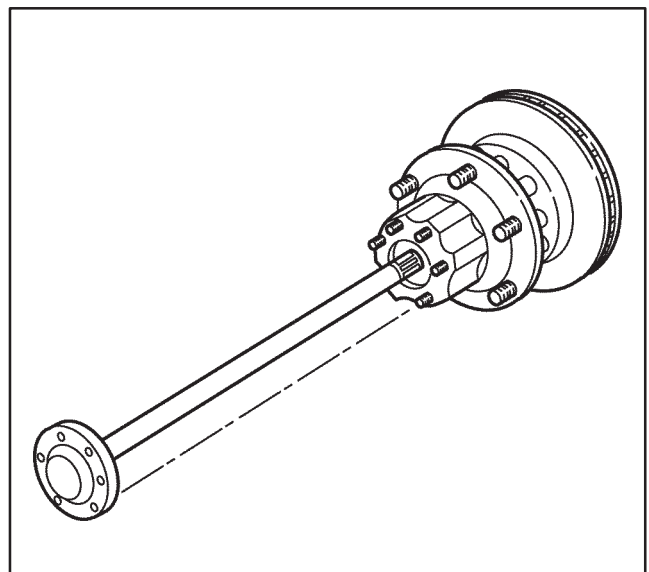

WRK42069

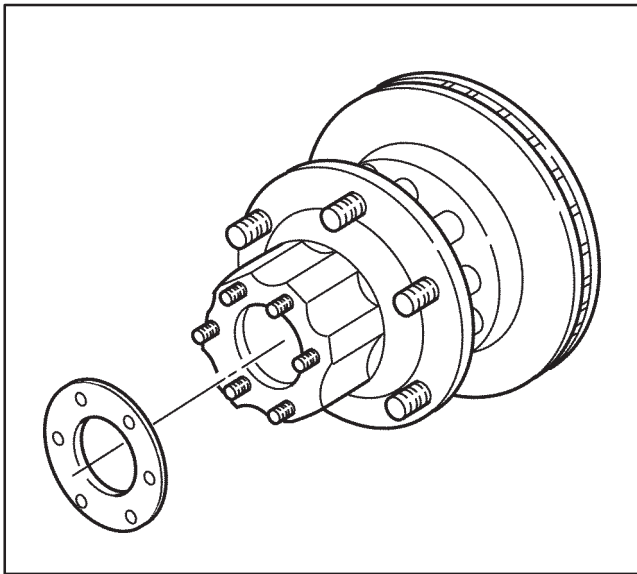

WRK42070

3. Remove the axle shaft flange gaskets.
4. Clean the mating surfaces on the axle shaft flanges and rear axle housing.

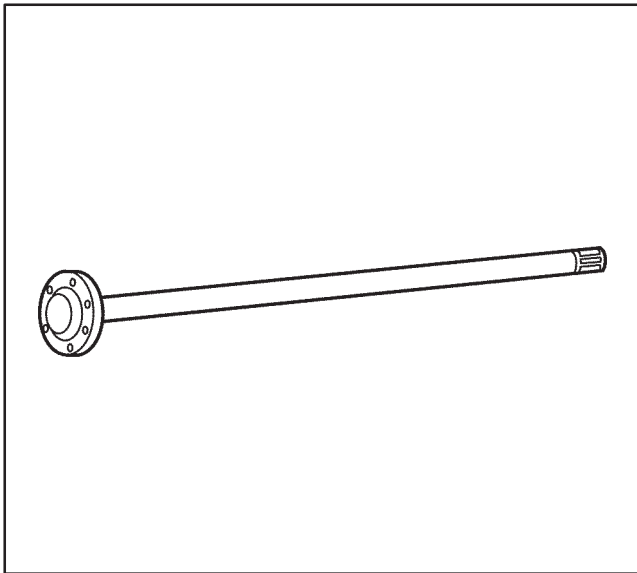

WRK42071

5. Inspect the axle shaft to see if it is bent.
6. Inspect the splines for chips, burns, cracking or excessive wear. Replace the axle shaft if any of those conditions exist.

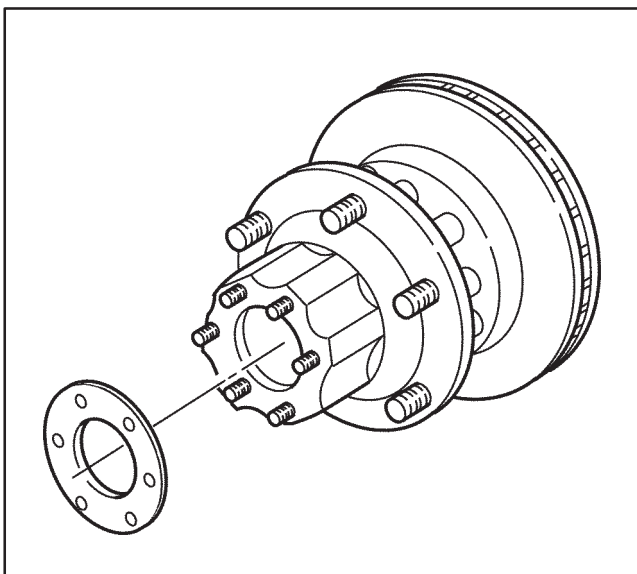

WRK42070

**Installation Procedure**

1. Install new axle flange gasket onto the wheel hub.

**Important:** Dip the spline end of the axle in rear axle lubricant. Refer to *Fluid and Lubricant Recommendations* in this supplement.

2. Install the axle shaft into the rear axle housing.

**Important:** Ensure that the axle shaft splines mesh into the differential side gear and that the holes in the axle shaft flange and gasket align with the holes in the hub.

3. Repeat the procedure for the other axle shaft, if removed.

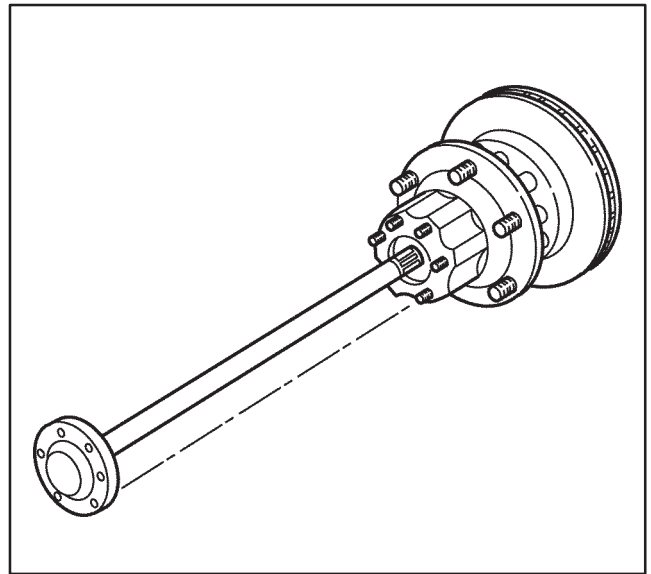

WRK42069

**Notice:** Refer to *Fastener Notice* in Cautions and Notices in the WCC Service Manual.

4. Install the split tapered dowels.
5. Install the axle shaft nuts.

**Tighten**

Tighten the axle shaft nuts to 70 N · m (55 lb ft).

6. Check the lubricant level in the rear axle and adjust as necessary. Refer to *Lubricant Change (Spicer Dana S135 and S150 14 Inch)* in this supplement.

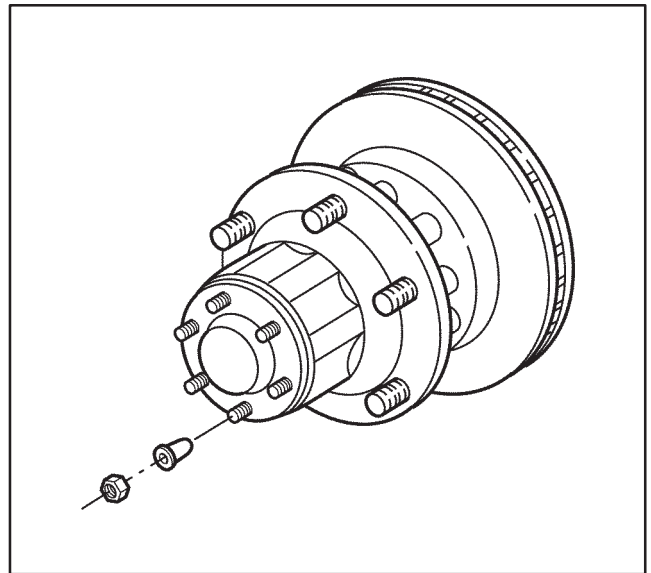

WRK42067

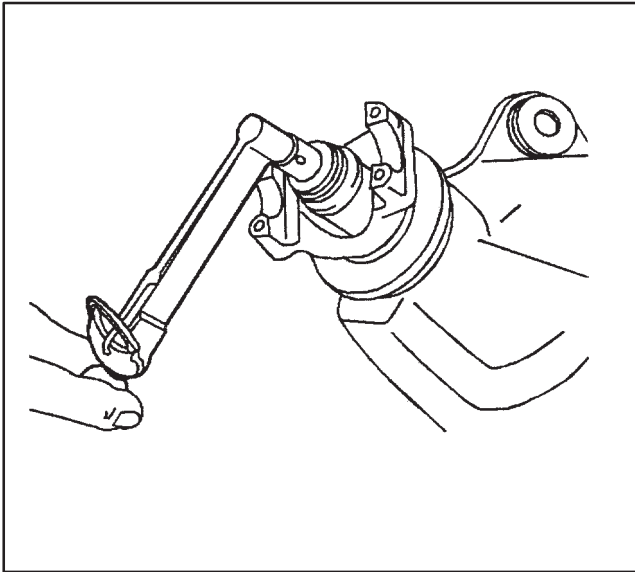

WRK42108

### Pinion Yoke and Oil Seal Replacement (American Axle 11 1/2 Inch)

#### Tools Required

- J 8614-01 Flange Holder and Remover  
Consisting of:
  - J 8614-2 Adapter
  - J 8614-3 Jack Screw
  - J 8614-10 Holder
- J 44414 Rear Axle Pinion Oil Seal Installer

#### Removal Procedure

1. Raise the vehicle. Refer to *Lifting and Jacking the Vehicle* in the WCC Service Manual.
2. Disconnect the propeller shaft. Refer to *Three Piece Propeller Shaft Replacement* in the WCC Service Manual.
3. Using an inch-pound torque wrench, measure and record the amount of torque required to rotate the pinion (rotating torque).

**Important:** This reading represents the combined preload of the pinion bearings, the pinion seal, and the differential side bearings.

4. Draw two arrows facing each other, one on the pinion stem and the other on the pinion yoke.
5. Record the number of exposed threads on the pinion stem for reference.

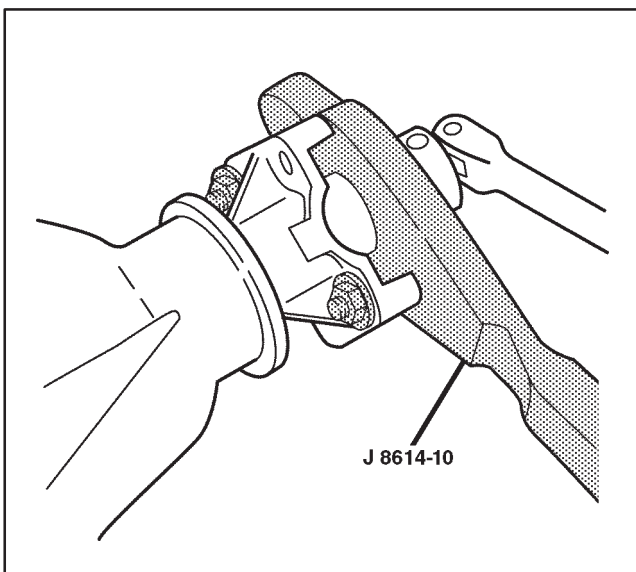

WRK42005

6. Install the J 8614-10 to the pinion yoke as shown.
7. Remove the pinion nut and washer.

8. Assemble the *J 8614-2*, *J 8614-3*, and *J 8614-10* as shown.
9. Remove the pinion yoke by holding the *J 8614-10* and turning the *J 8614-3* with a 1-inch wrench.

**Notice:** Be careful not to damage any machined surfaces when prying out the oil seal. Damaging the machined surfaces may cause the oil seal to leak and could result in premature component failure due to a lack of lubrication.

10. Carefully pry out the oil seal with a universal oil seal remover.
11. Clean any foreign material from the seal contact areas.
12. Inspect the following:
  - The oil seal mating surfaces for any burrs or other damage that might cause seal failure
  - Yoke and deflector for any abnormality such as cracks or distortion.
13. Replace parts as necessary.

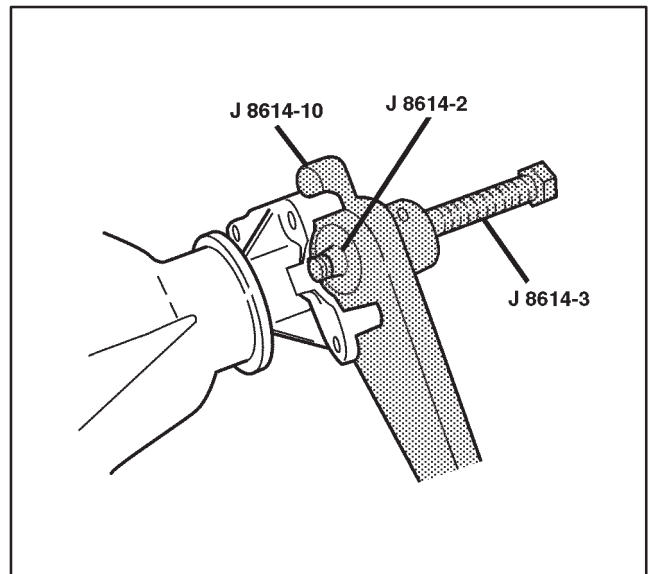

WRK42110

### Installation Procedure

1. Coat the lip of the new oil seal with extreme pressure lubricant such as GM P/N 9985038.
2. Install the new pinion oil seal using the *J 44414*.

**Important:** When applying sealant, do not coat the outer pinion bearing.

3. Apply sealant (GM P/N 12346004 or equivalent) to the splines of the pinion yoke.
4. Aligning the marks made during removal, slide the pinion yoke onto the pinion shaft.

**Notice:** Do not hammer the pinion yoke onto the pinion shaft because damage to pinion components is likely to occur.

5. Seat the pinion yoke on the pinion shaft by tapping it with a soft-faced hammer until a few pinion shaft threads show through the yoke.

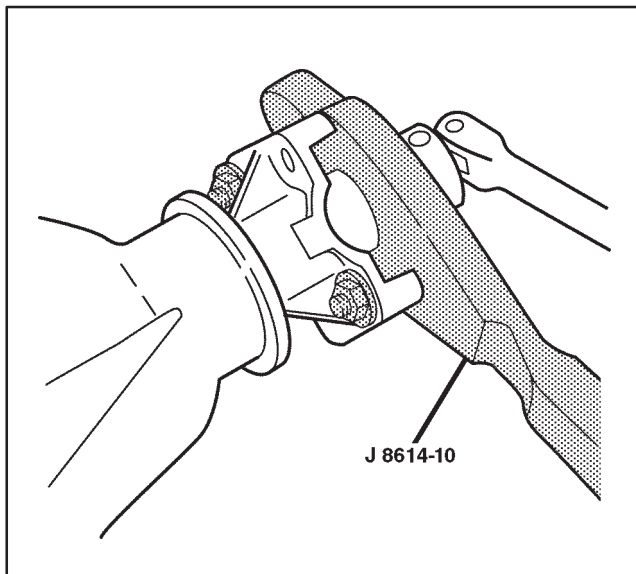

WRK42005

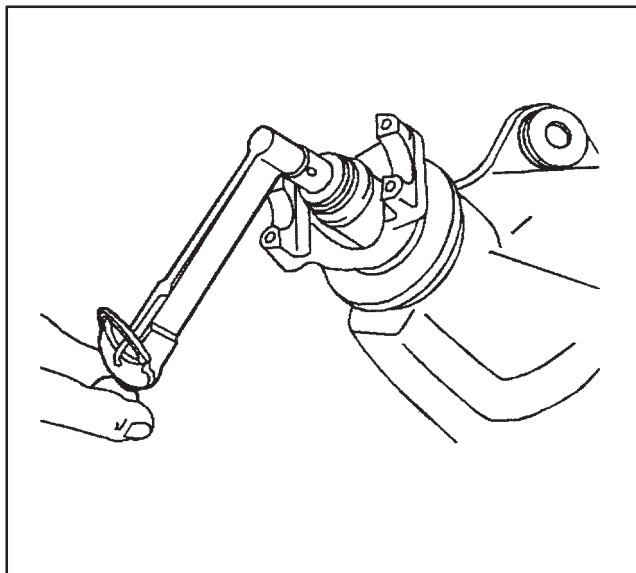

WRK42108

**Notice:** Refer to *Fastener Notice* in Cautions and Notices in the WCC Service Manual.

6. Install the pinion washer and a new pinion nut.
7. Install the *J 8614-10* onto the pinion yoke as shown.

**Notice:** Be careful not to over torque the pinion nut. If the rotating torque value is exceeded, the pinion will have to be removed and a new collapsible spacer installed.

**Important:** Rotate the pinion periodically as you tighten the pinion nut. This will help to seat the pinion bearings.

8. Hold the *J 8614-10* as you tighten the pinion nut until the pinion endplay is just taken up.

9. Measure and record the rotating torque of the pinion using an inch-pound torque wrench.
10. Compare this measurement to the reading recorded during disassembly.

**Notice:** Be careful not to over torque the pinion nut. If the rotating torque value is exceeded, the pinion will have to be removed and a new collapsible spacer installed.

**Important:** In this case, the rotating torque value represents the combined preload of the pinion bearings, the pinion seal, and the differential side bearings.

11. Check the rotating torque value frequently as you tighten the pinion nut.

#### **Tighten**

Tighten the pinion nut in small increments, as needed, until the rotating torque is 0.40 to 0.57 N·m (3 to 5 lb in) higher than measured before disassembly.

12. Once the specified torque is reached, rotate the pinion to ensure the pinion bearings have seated.
13. Connect the propeller shaft. Refer to *Three Piece Propeller Shaft Replacement* in the WCC Service Manual.
14. Check the rear axle lubricant level and correct, if necessary. Refer to *Lubricant Level Check (American Axle 11 1/2 Inch)* in this supplement.
15. Lower the vehicle.



## Pinion Yoke and Oil Seal Replacement (Spicer Dana S135 and S150 14 Inch)

### Tools Required

- J 3453 Holding Bar
- J 7804-01 Puller

### Removal Procedure

1. Raise the vehicle. Refer to *Lifting and Jacking the Vehicle* in the WCC Service Manual.
2. Disconnect the propeller shaft. Refer to *Three Piece Propeller Shaft Replacement* in the WCC Service Manual.
3. Draw two arrows facing each other, one on the pinion stem and the other on the pinion yoke.

**Important:** The use of a torque multiplier is recommended to remove the pinion nut. The torque specification on this nut is 1,220 N·m (900 lb ft).

4. Hold the pinion yoke with the J 3453 and remove the pinion nut and washer.
5. Remove the pinion yoke using the J 7804-01 as shown.

**Notice:** Be careful not to damage any machined surfaces when prying out the oil seal. Damaging the machined surfaces may cause the oil seal to leak and could result in premature component failure due to a lack of lubrication.

6. Remove the pinion oil seal using a suitable seal puller.
7. Clean any foreign material from the seal contact areas.
8. Inspect the following:
  - The oil seal mating surfaces for any burrs or other damage that might cause seal failure.
  - Pinion yoke and deflector for any abnormality such as cracks or distortion.
  - Pinion yoke for grooves in the sealing surface caused by contaminants. If grooves can be detected with the fingernail, the yoke must be repaired with an approved wear sleeve or replaced.
9. Replace parts as necessary.

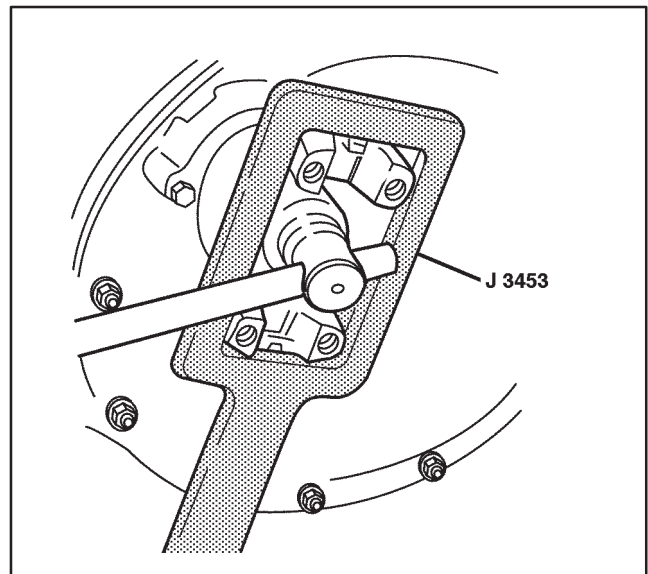

WRK42074

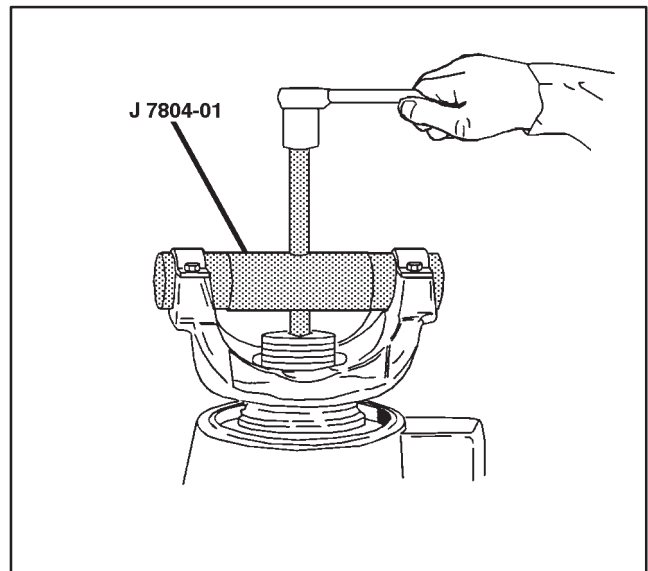

WRK42020

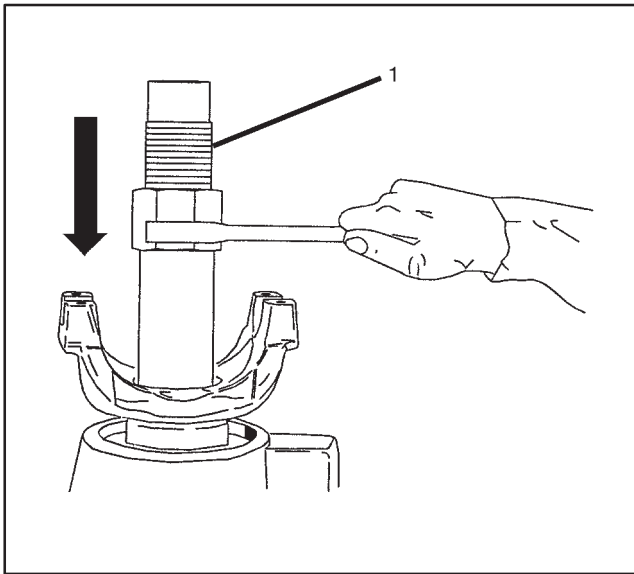

WRK42024

### Installation Procedure

1. Coat the lip of the new oil seal with extreme pressure lubricant such as GM P/N 9985038.
2. Install the new pinion oil seal using a suitable seal installer.

**Important:** when applying sealant, do not coat the outer pinion bearing.

3. Apply sealant (GM P/N 12346004 or equivalent) to the splines of the pinion yoke.
4. Aligning the marks made during removal, slide the pinion yoke onto the pinion shaft.

**Notice:** Do not hammer the pinion yoke onto the pinion shaft because damage to pinion components is likely to occur.

5. Using a yoke installation tool (1) (Spicer Dana P/N DST 1009, or equivalent), install the yoke on the pinion stem.
6. Apply thread-locking compound (Loctite® 680, or equivalent) to the pinion threads.

**Notice:** Refer to *Fastener Notice* in Cautions and Notices in the WCC Service Manual.

**Important:** The use of a torque multiplier is recommended to install the pinion nut. The torque specification on this nut is 1,220 N·m (900 lb ft).

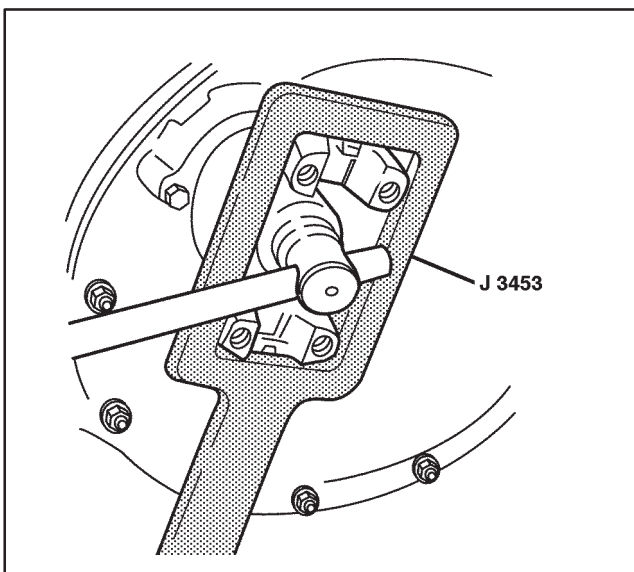

WRK42074

7. Using J 3453, install the pinion washer with the new pinion nut.

### Tighten

Tighten the pinion nut to 1,220 N·m (900 lb ft).

8. Connect the propeller shaft. Refer to *Three Piece Propeller Shaft Replacement* in the WCC Service Manual.
9. Check the lubricant level in the rear axle and adjust as necessary. Refer to *Lubricant Change (Spicer Dana S135 and S150 14 Inch)* in this supplement.
10. Lower the vehicle.

## Axle Disassemble (American Axle 11 1/2 Inch)

### Tools Required

- J 2222-C Wheel Bearing Nut Wrench
- J 8614-01 Flange Holder and Remover  
Consisting of:
  - J 8614-2 Adapter
  - J 8614-3 Jack Screw
  - J 8614-10 Holder
- J 24429 Side Bearing Nut Wrench
- J 24421 Pinion Remover
- J 22912-01 Split Plate Bearing Puller

1. Remove the rear axle fill plug and seal.

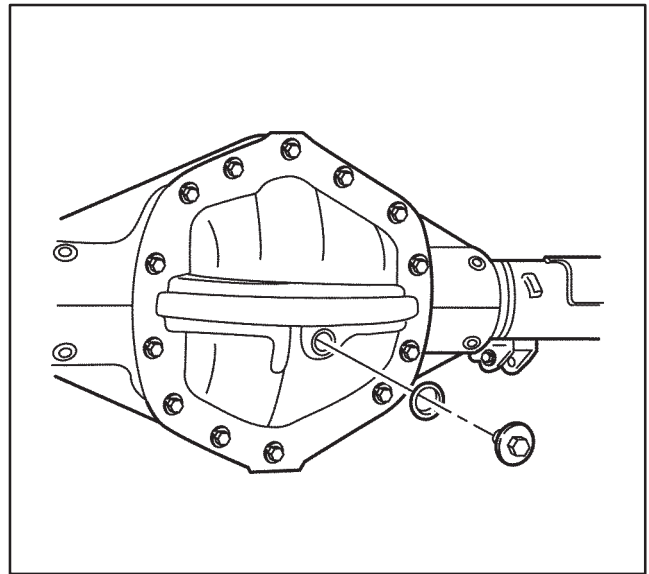

WRK42081

2. Place a suitable container under the rear axle drain plug.
3. Remove the rear axle drain plug and allow the fluid to drain into the container.

**Important:** An excessive accumulation of metal particles is an indication of extreme wear.

4. Inspect the drain plug for excessive metal particle accumulation.

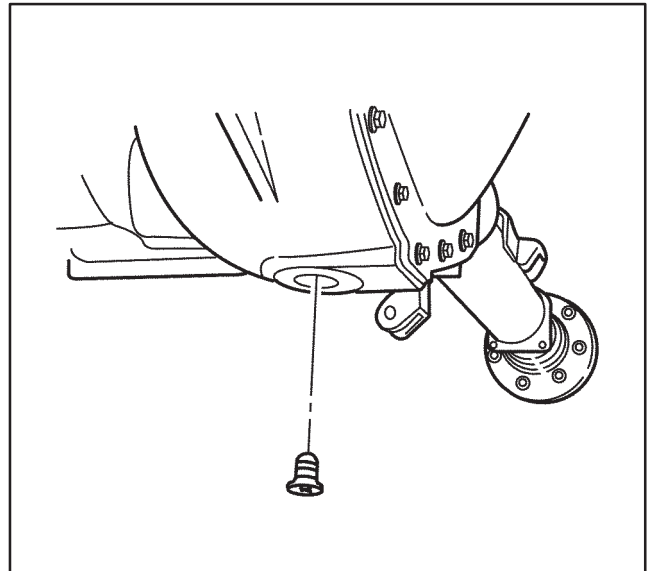

WRK42104

5. Remove the axle shaft flange bolts.
6. Remove the rear axle shafts as follows:
- 6.1. Lightly tap the axle shaft flange with a soft-faced hammer in order to loosen the shaft.
  - 6.2. Grip the rib on the axle shaft flange with locking pliers.
  - 6.3. Pull on the axle shaft using a twisting motion to free its splines from the differential side gears.
  - 6.4. Once the axle shaft is clear of the differential side gears, pull it straight out of the rear axle housing.
  - 6.5. Remove the other axle shaft in the same manner.
7. Remove the axle shaft flange gaskets.
8. Clean the mating surfaces on the axle shaft flanges and rear axle housing.

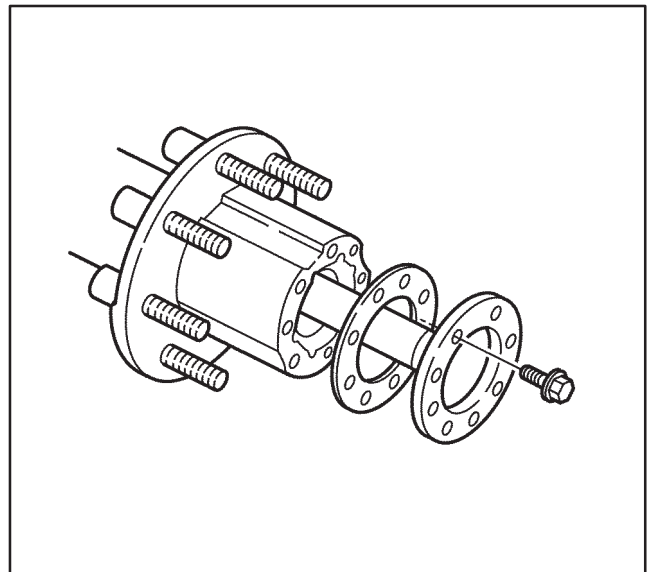

WRK42106

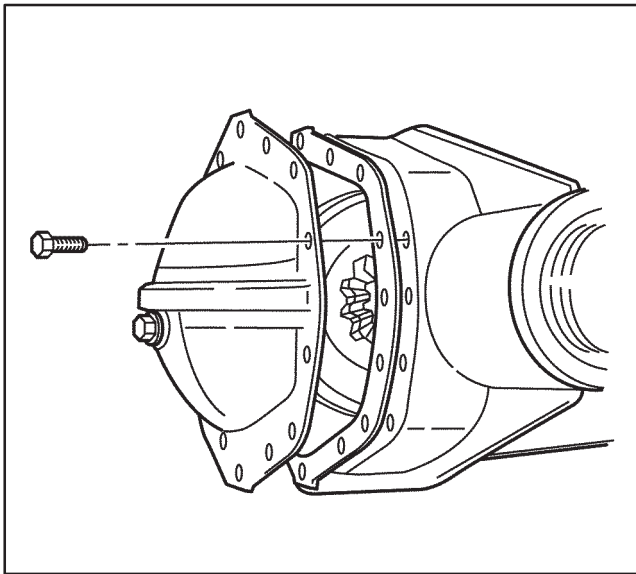

WRK42107

9. Remove the rear axle housing cover bolts.
10. Remove the rear axle housing cover from the rear axle housing.
11. Remove the rear axle housing cover gasket.
12. Clean the mating surfaces on the rear axle housing and the cover.

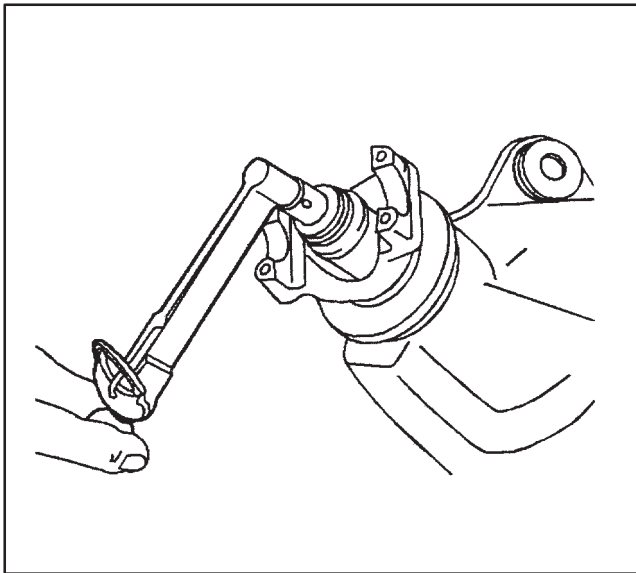

WRK42108

13. Using an inch-pound torque wrench, measure and record the amount of torque required to rotate the pinion (rotating torque).

**Important:** This reading represents the combined preload of the pinion bearings, the pinion seal, and the differential side bearings.

14. Draw two arrows facing each other, one on the pinion stem and the other on the pinion yoke.
15. Record the number of exposed threads on the pinion stem for reference.

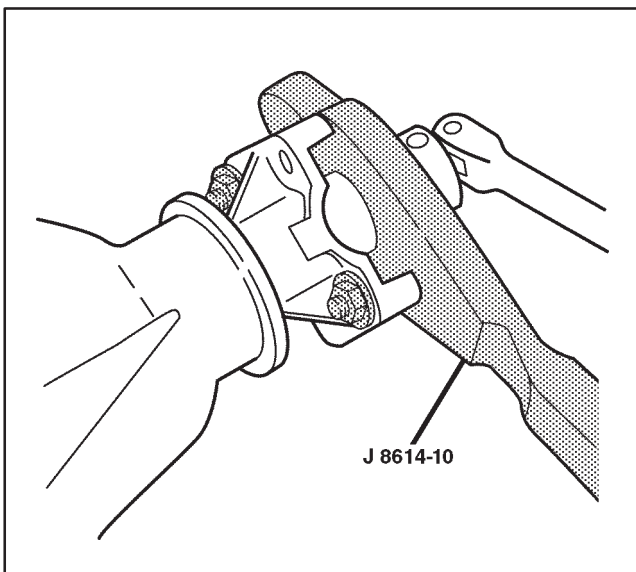

WRK42005

16. Install the *J 8614-10* to the pinion yoke as shown.
17. Remove the pinion nut and washer.

18. Assemble the *J 8614-2*, *J 8614-3*, and *J 8614-10* as shown.
19. Remove the pinion yoke by holding the *J 8614-10* and turning the *J 8614-3* with a 1-inch wrench.

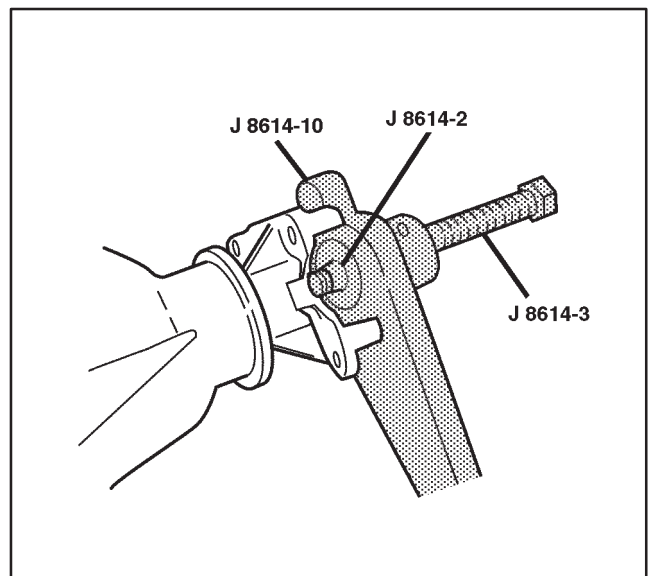

WRK42110

20. Remove the rear axle nut retaining ring.

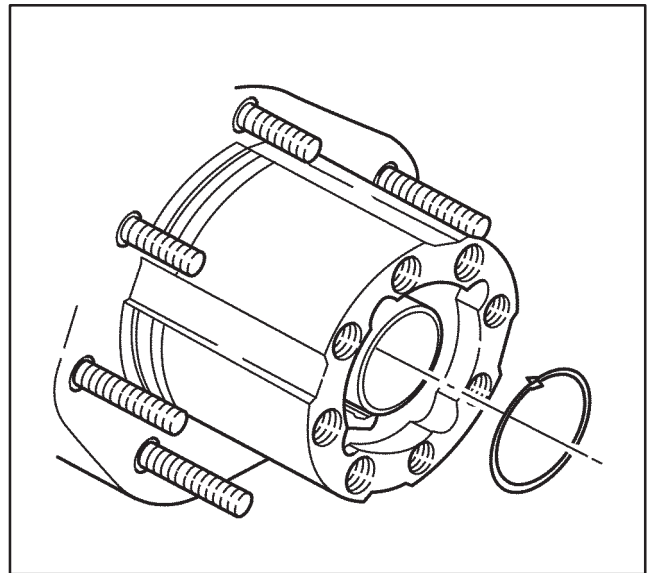

WRK42111

21. Remove the key.

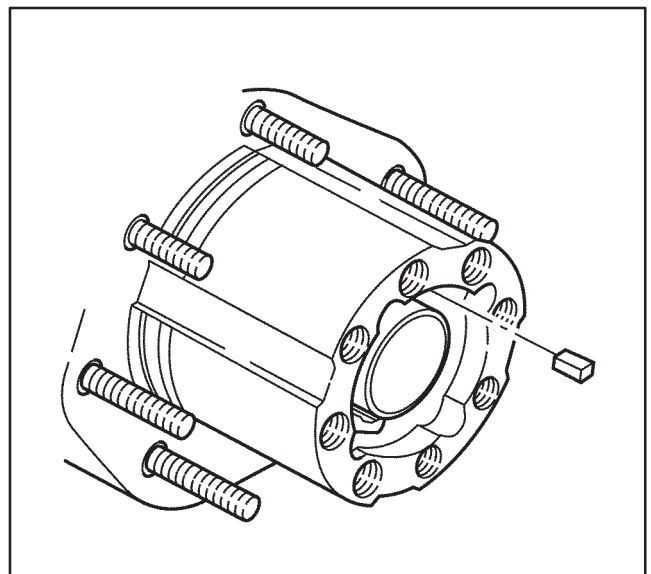

WRK42112

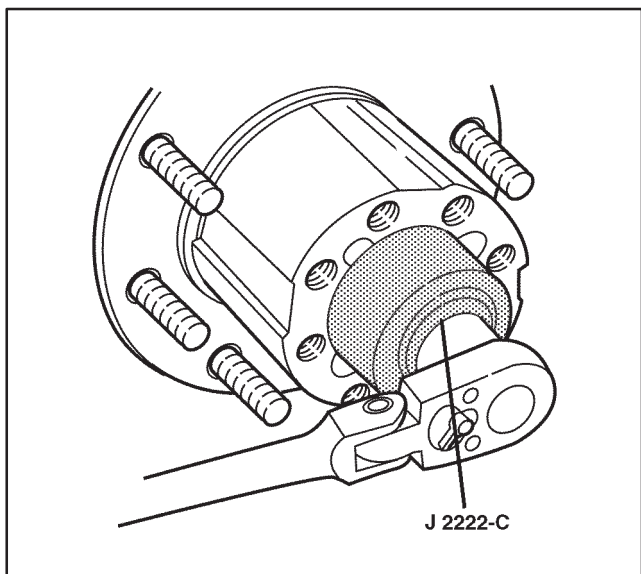

WRK42113

22. Loosen the adjusting nut using the *J 2222-C*.

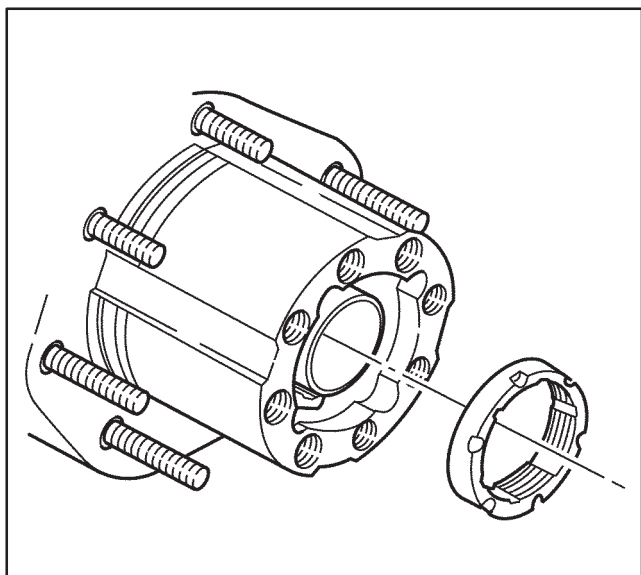

WRK42114

23. Remove the adjusting nut.

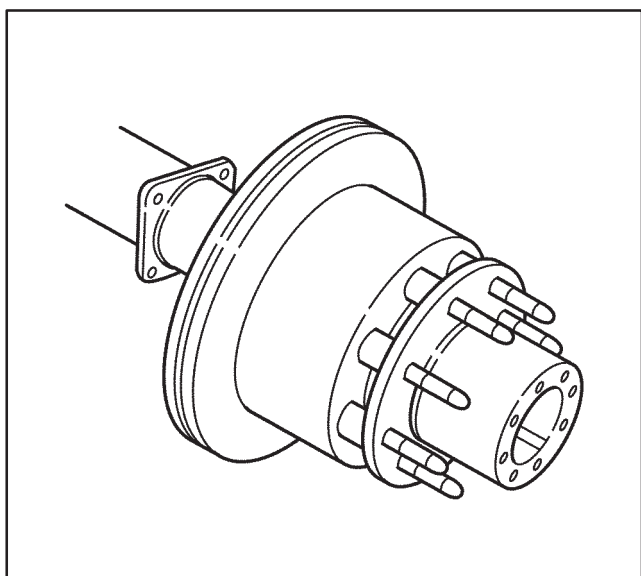

WRK42115

24. Remove the hub and rotor assembly from the axle housing.

25. Remove the oil seal from the hub.

26. Remove the differential bearing adjuster nut lock bolts.
27. Remove the differential bearing adjuster nut locks.

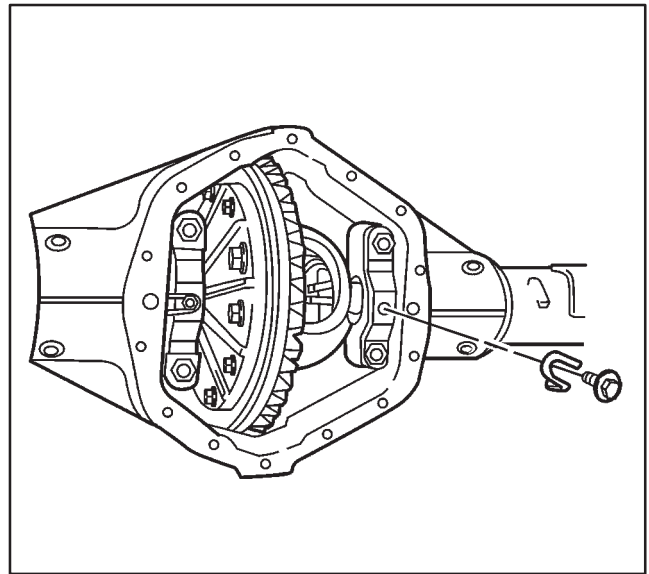

WRK42087

28. Remove the bearing caps and mounting bolts.
29. Mark the bearing caps left and right.

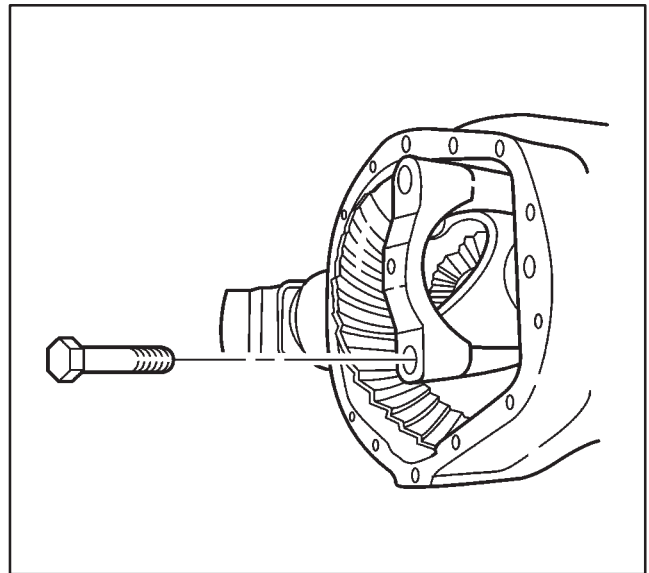

WRK42088

30. Loosen the differential bearing adjusters using the J 24429.

**Caution:** To prevent personal injury and component damage, support the differential case when removing it from the housing. If the case is not supported, it could fall and cause personal injury or component damage.

**Notice:** When removing the differential, be careful not to damage the cover gasket surfaces. If the surfaces are damaged, lubricant may leak out and cause premature failure of the axle assembly components.

31. Remove the differential case from the rear axle housing.
32. Remove the bearing cups and spacers.
33. Mark the bearing cups and spacers as left and right.
34. Place the bearing cups and spacers with their respective bearing caps.

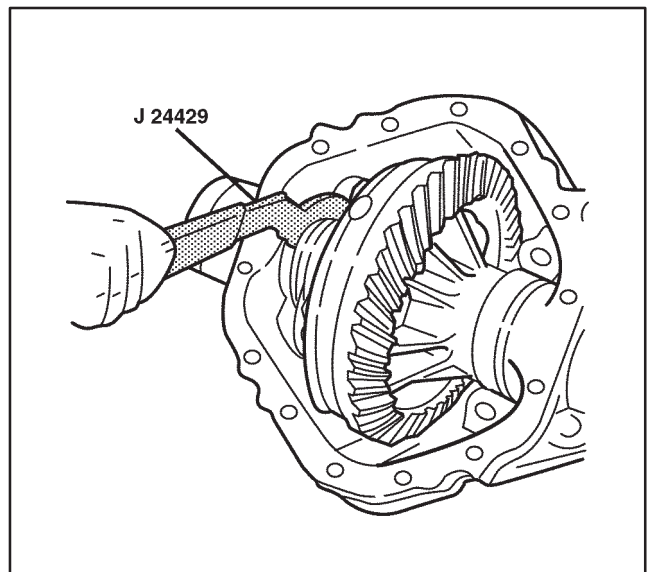

WRK42091



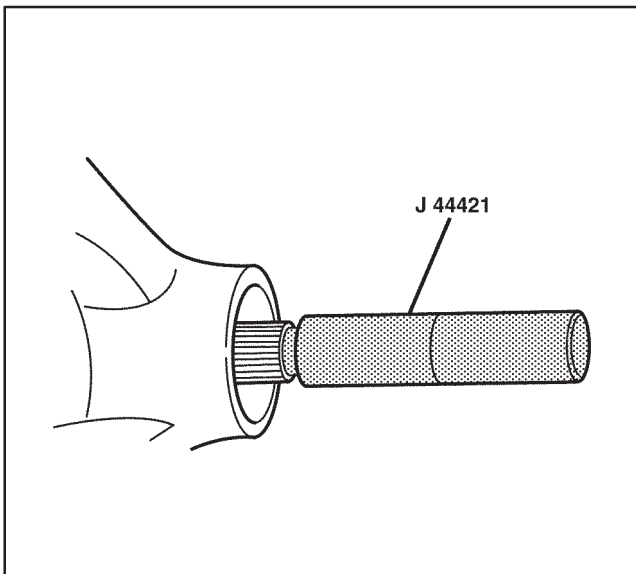

WRK42093

35. Install the *J 44421* as shown.

**Important:** Make sure that the *J 44421* is fully seated on the pinion.

**Notice:** When removing the pinion, do not let the pinion fall on the ground or damage is likely to occur.

36. Drive out the pinion by tapping the *J 44421* with a hammer.

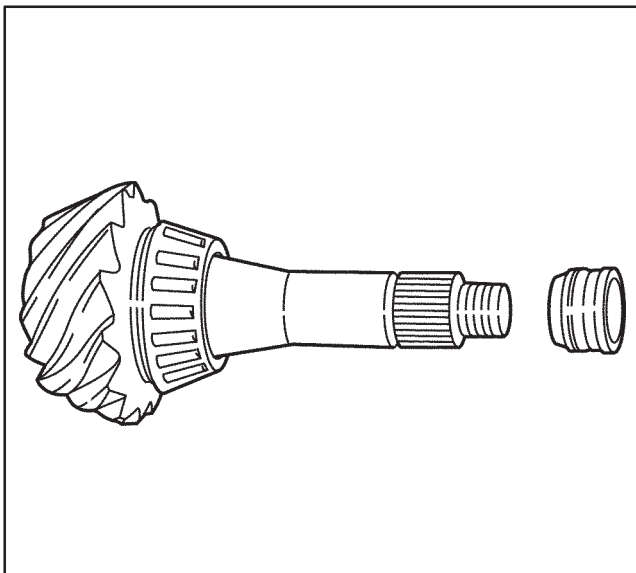

WRK42092

37. Remove the collapsible spacer from the pinion and discard it.

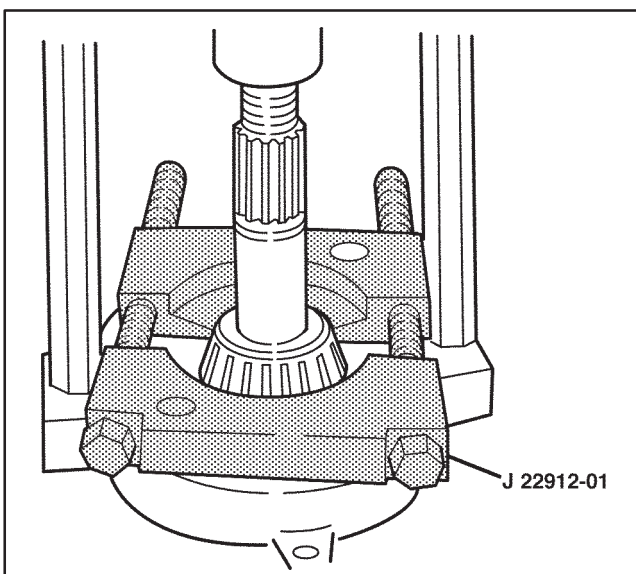

WRK42083

38. Remove the pinion inner bearing and selective shims using the *J 22912-01* as shown.

**Notice:** When removing the pinion oil seal, be careful not to damage the rear axle housing.

39. Remove the pinion oil seal using a suitable seal removal tool.

**Important:** When removing the pinion bearing cups, move the drift back and forth between one side of a bearing cup and the other in order to work the cup out of the housing evenly.

40. Remove the pinion bearing cups using a hammer and a brass drift in the slots provided.

41. Clean and inspect all parts before assembly.



## Axle Assemble (American Axle 11 1/2 Inch)

### Tools Required

- J 8092 Driver Handle
- J 8608 Outer Pinion Bearing Race Installer
- J 8614-01 Flange Holder and Remover  
Consisting of:
  - J 8614-2 Adapter
  - J 8614-3 Jack Screw
  - J 8614-10 Holder
- J 44412 Pinion Bearing Installer
- J 44414 Rear Axle Pinion Oil Seal Installer
- J 44417 Rear Pinion Bearing Race Installer
- J 24429 Side Bearing Nut Wrench

1. Install the pinion outer bearing cup using the J 8608 and J 8092 as shown.

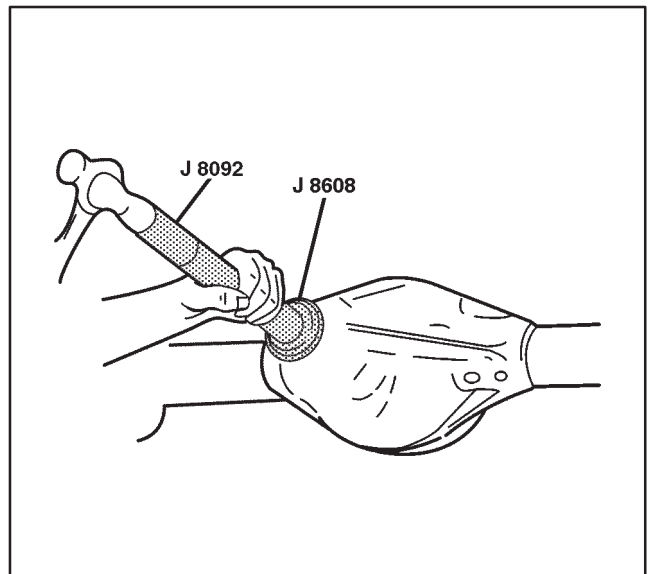

WRK42084

2. Install the pinion inner bearing cup using the J 44417 and J 8092 as shown.

3. Determine the selective shim thickness. Refer to *Pinion Depth Adjustment (American Axle 11 1/2 Inch)* in this supplement.

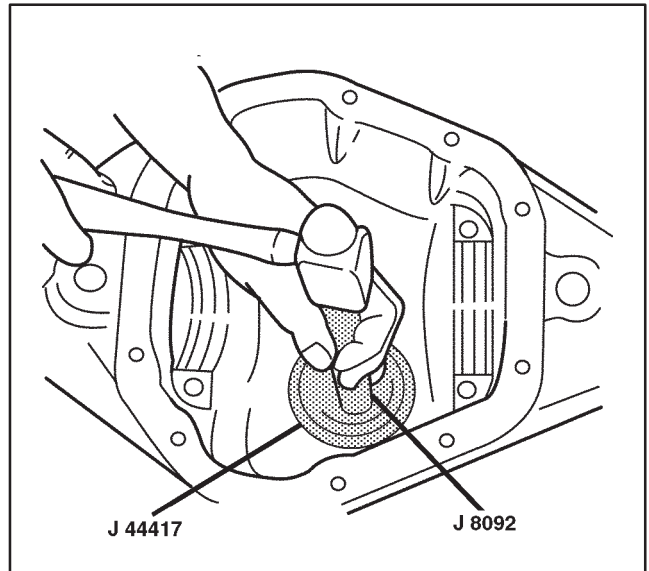

WRK42085

4. Slide the selective shim and then the inner pinion bearing onto the pinion shaft.

**Important:** The bearing and selective shim must seat against the shoulder on the gear.

5. Install the pinion inner bearing using the J 44412 as shown.

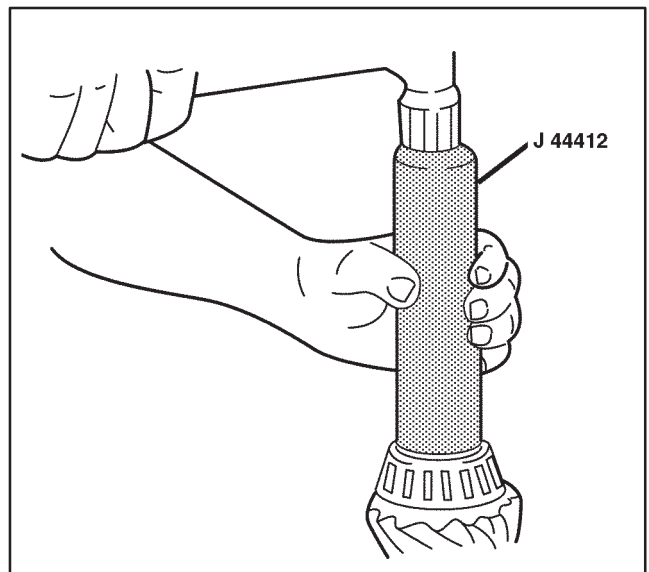

WRK42011

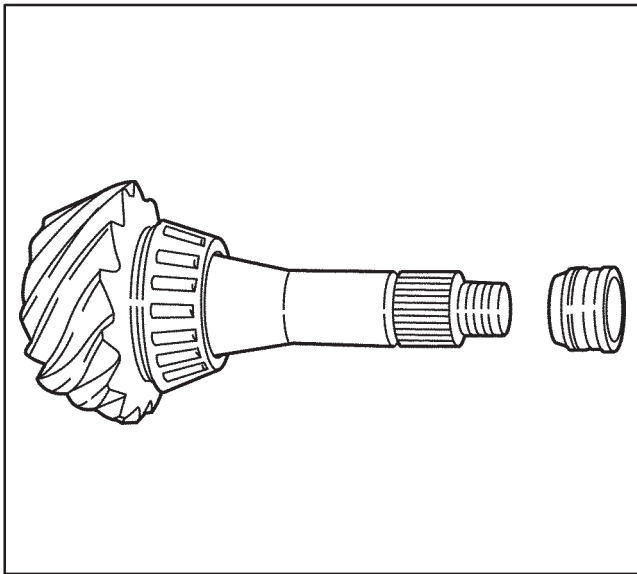

WRK42092

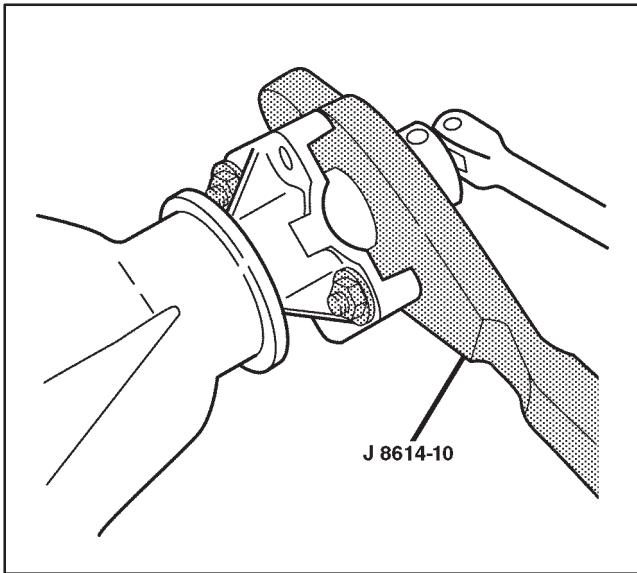

WRK42005

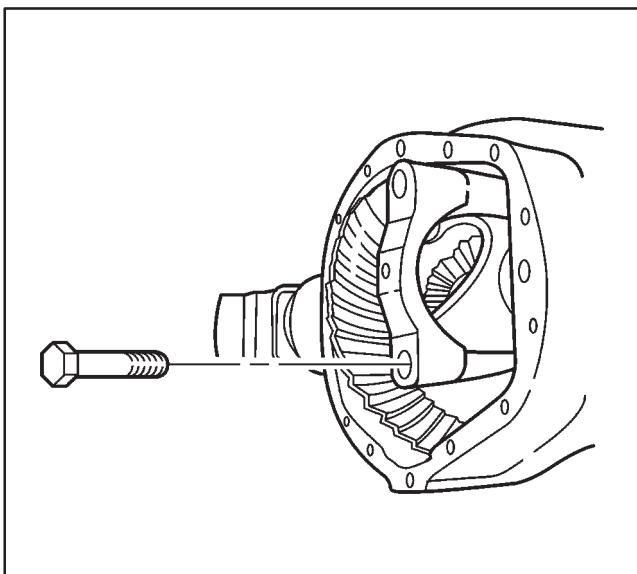

WRK42088

6. Install a new collapsible spacer.
7. Lubricate the pinion bearings with axle lubricant. Refer to *Fluid and Lubricant Recommendations* in this supplement.
8. Install the pinion into the rear axle housing.
9. Install the outer bearing onto the pinion shaft.
10. Install a new pinion oil seal using the *J 44414*.
11. Apply sealant (GM P/N 12346004 or equivalent) to the splines of the pinion yoke.
12. Aligning the marks made during removal, slide the pinion yoke onto the pinion shaft.

**Notice:** Do not hammer the pinion yoke onto the pinion shaft because damage to pinion components is likely to occur.

13. Seat the pinion yoke on the pinion shaft by tapping it with a soft-faced hammer until a few pinion shaft threads show through the yoke.

**Notice:** Refer to *Fastener Notice* in Cautions and Notices in the WCC Service Manual.

14. Install the pinion washer and a new pinion nut.
15. Install the *J 8614-10* onto the pinion yoke as shown.

**Notice:** Be careful not to over torque the pinion nut. If the rotating torque value is exceeded, the pinion will have to be removed and a new collapsible spacer installed.

**Important:** Rotate the pinion periodically as you tighten the pinion nut. This will help to seat the pinion bearings.

16. Hold the *J 8614-10* as you tighten the pinion nut until the pinion endplay is just taken up.

17. Install the differential bearing adjusters.
18. Lubricate the differential side bearings with axle lubricant. Refer to *Fluid and Lubricant Recommendations* in this supplement.
19. Place the differential case, with the bearing cups installed, into the rear axle housing.
20. Install the bearing caps and the bearing cap mounting bolts. Do not torque the bearing cap bolts at this time.

21. Tighten the differential side bearing adjusters using the *J 24429* until they are snug against the differential bearing cups.

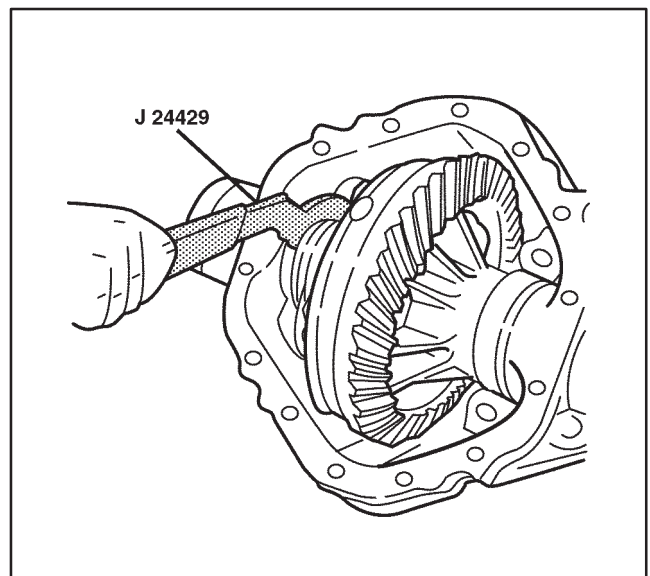

WRK42091

**Notice:** Be careful not to over torque the pinion nut. If the rotating torque value is exceeded, the pinion will have to be removed and a new collapsible spacer installed.

22. Check the rotating torque value frequently as you tighten the pinion nut.

**Tighten**

- If old pinion bearings are being reused, tighten the pinion nut in small increments, as needed, until the rotating torque is 0.40 to 0.57 N·m (3 to 5 lb in) higher than measured before disassembly.
  - If new pinion bearings are being used, tighten the pinion nut in small increments, as needed, until the absolute rotating torque is 1.7 to 3.4 N·m (15 to 30 lb in).
23. Once the specified torque is reached, rotate the pinion to ensure the pinion bearings have seated.
24. Recheck the rotating torque and adjust if necessary.
25. Adjust the backlash. Refer to *Backlash Adjustment (American Axle 10 1/2 and 11 1/2 Inch)* in this supplement.
26. Perform a gear tooth contact pattern check. Refer to *Gear Tooth Contact Pattern Check (American Axle 10 1/2 and 11 1/2 Inch)* in this supplement.

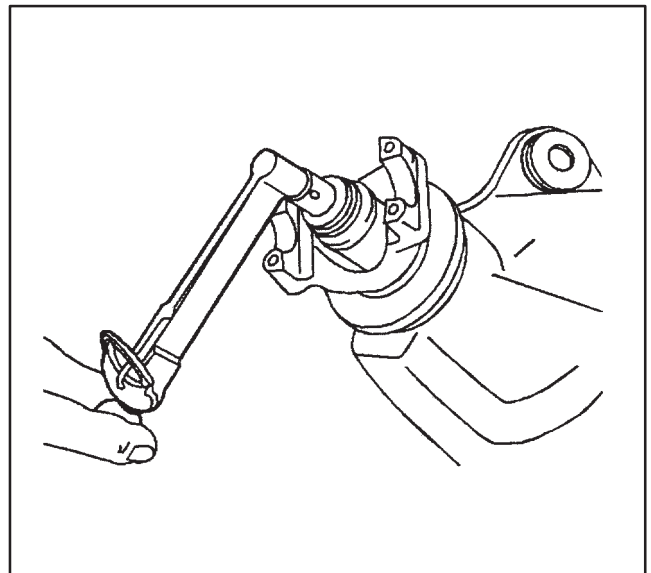

WRK42108

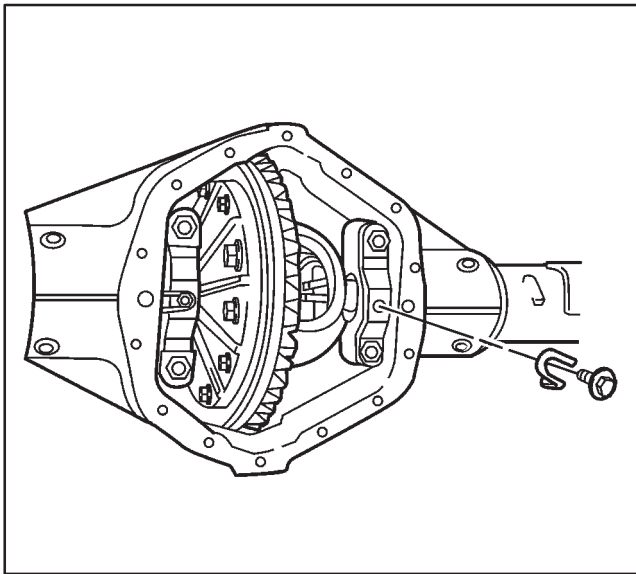

WRK42087

27. Install the differential adjusting nut locks.
28. Install the differential adjusting nut lock bolts.

**Tighten**

Tighten the differential adjusting nut lock bolts to 27 N·m (20 lb ft).

29. Repack the wheel bearings. Refer to *Fluid and Lubricant Recommendations* in this supplement.
30. Install the inner wheel bearings and new oil seals. Refer to *Oil Seal and/or Bearing Replacement (Disc)* in the WCC service manual.
31. Install the hub and rotor assemblies. Refer to *Hub and Rotor Assembly Replacement* in the WCC Service Manual.
32. Adjust the wheel bearings. Refer to *Wheel Bearing Adjustment (Disc Brakes)* in the WCC Service Manual.

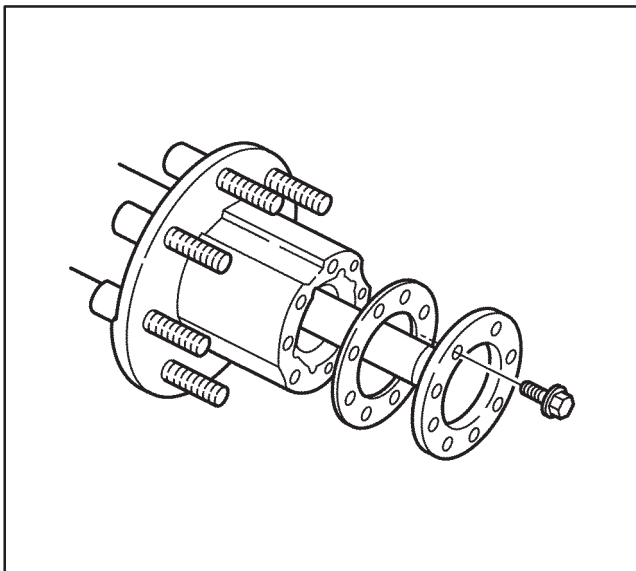

WRK42106

33. Install new gaskets onto the axle shafts.
34. Install the axle shafts and gaskets into the rear axle housing.

**Important:** Ensure that the axle shaft splines mesh into the differential side gear and that the holes in the axle shaft flanges and gaskets align with the holes in the hubs.

35. Install the axle shaft bolts.

**Tighten**

Tighten the axle shaft bolts to 156 N·m (115 lb ft).

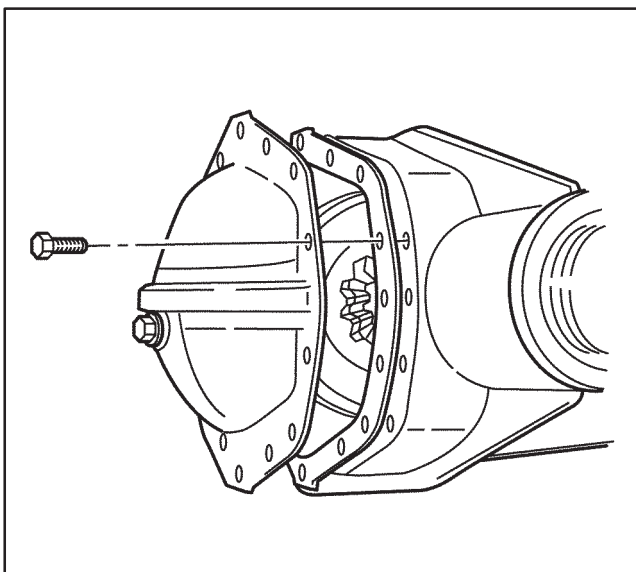

WRK42107

36. Install the rear axle housing cover and a new gasket.
37. Install the rear axle housing cover bolts.

**Tighten**

Tighten the rear axle housing cover bolts, alternately in a star pattern, to 40 N·m (30 lb ft).

38. Install the drain plug.

**Tighten**

Tighten the drain plug to 33 N·m (24 lb ft).

39. Fill the rear axle with the proper quantity of lubricant. Refer to *Lubrication Specifications and Fluid and Lubricant Recommendations* in this supplement.

40. Install the fill plug and seal.

**Tighten**

Tighten the fill plug to 33 N·m (24 lb ft).

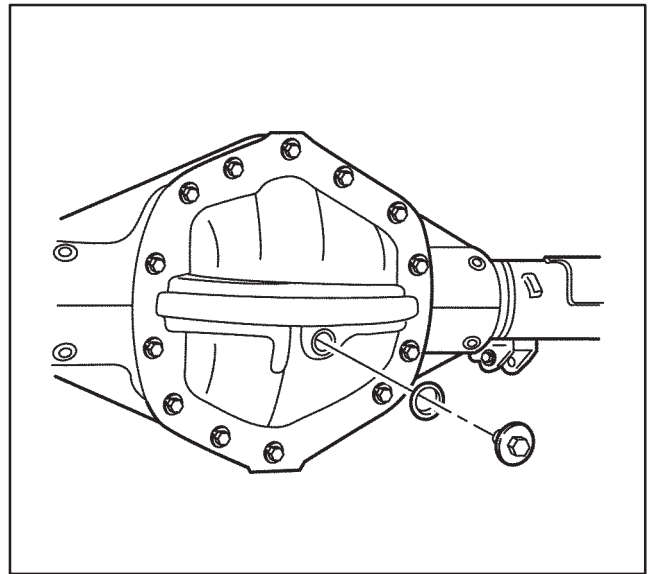

WRK42081

**Rear Axle Housing Cover and Gasket Replacement  
(American Axle 10 1/2 and 11 1/2 Inch)**

**Removal Procedure**

1. Raise the vehicle. Refer to *Lifting and Jacking the Vehicle* in the WCC Service Manual.
2. Place a suitable container under the rear axle housing cover to catch draining lubricant.
3. Remove the rear axle drain plug and let the lubricant drain into the container.

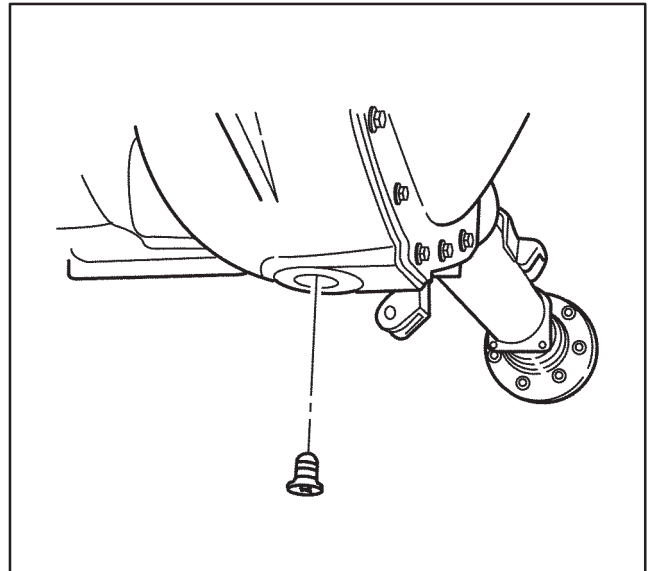

WRK42104

4. Remove the rear axle housing cover bolts.
5. Remove the rear axle housing cover and gasket from the axle housing.
6. Remove any gasket material from the rear axle housing and the rear axle housing cover.

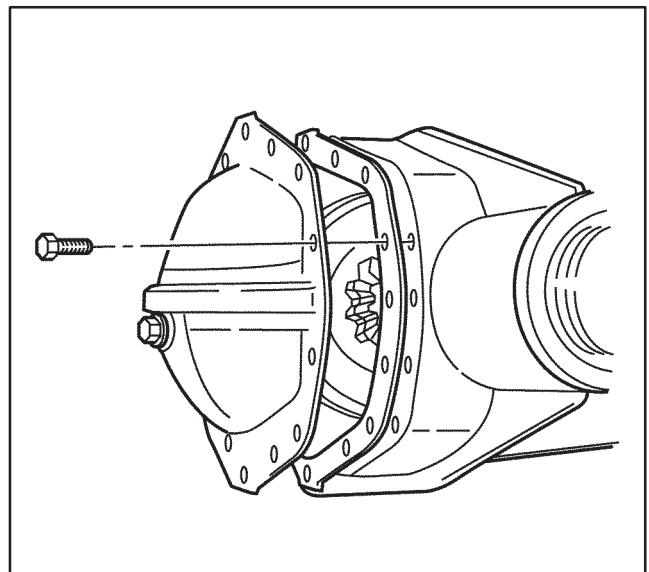

WRK42107

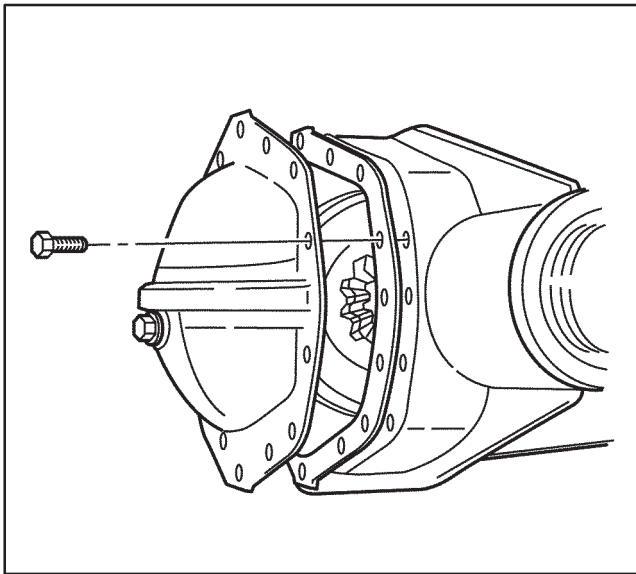

WRK42107

**Installation Procedure**

1. Install the rear axle housing cover and a new gasket.

**Notice:** Refer to *Fastener Notice* in Cautions and Notices in the WCC Service Manual.

2. Install the rear axle housing cover bolts.

**Tighten**

Tighten the rear axle housing cover bolts, alternately in a star pattern, to 40 N · m (30 lb ft).

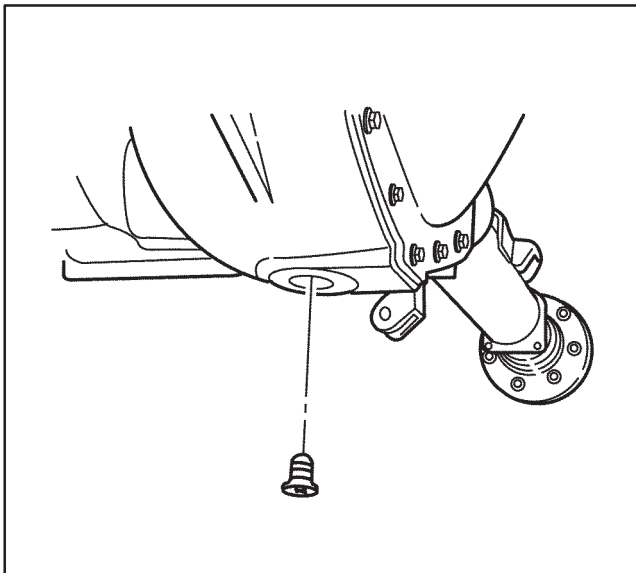

WRK42104

3. Install the rear axle drain plug.

**Tighten**

Tighten the rear axle drain plug to 33 N · m (24 lb ft).

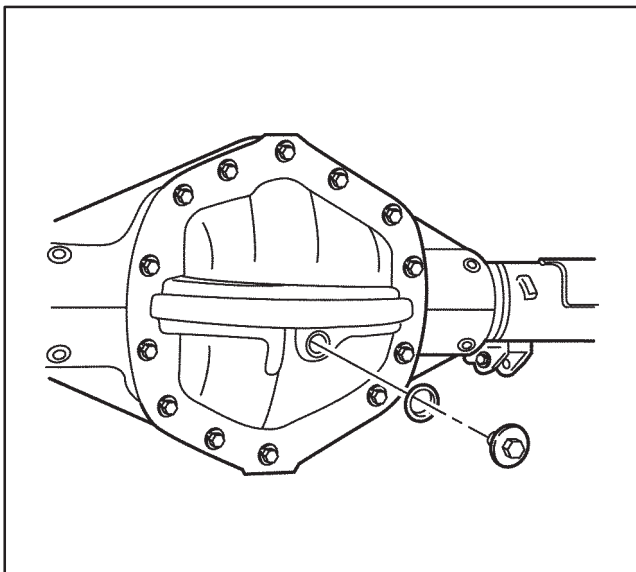

WRK42081

4. Remove the rear axle fill plug and seal.
5. Fill the rear axle with the proper type and quantity of lubricant. Refer to *Lubrication Specifications* and *Fluid and Lubricant Recommendations* in this supplement.
6. Install the rear axle fill plug and seal.

**Tighten**

- Tighten the rear axle fill plug to 24 N · m (18 lb ft) on 10 1/2 inch axles.
- Tighten the rear axle fill plug to 33 N · m (24 lb ft) on 11 1/2 inch axles.

7. Lower the vehicle.

## Axle Housing Replacement (American Axle 10 1/2 and 11 1/2 Inch)

### Removal Procedure

1. Raise the vehicle. Refer to *Lifting and Jacking the Vehicle* in the WCC Service Manual.
2. Remove the rear axle assembly. Refer to *Axle Replacement (10 1/2 in. Ring Gear)* in the WCC Service Manual or *Axle Replacement (American Axle 11 1/2 Inch)* in this supplement.
3. Remove the axle shafts. Refer to *Axle Shaft Replacement (All Models)* in the WCC Service Manual for 10 1/2 inch axles or *Axle Shaft Replacement (American Axle 11 1/2 Inch)* in this supplement.
4. Remove the brake calipers. Refer to *Brake Caliper Replacement (Rear)* in the WCC Service Manual for 10/1/2 inch axles or *Brake Caliper Replacement (American Axle 11 1/2 Inch)* in this supplement.
5. Remove the hub and rotor assemblies. Refer to *Hub and Rotor Assembly* in the WCC Service Manual.
6. Remove the brake caliper mounting plates. Refer to *Brake Caliper Mounting Plate Replacement* in the WCC Service Manual.
7. Remove the rear axle housing cover and gasket. Refer to *Axle Housing Cover and Gasket Replacement (American Axle 10 1/2 and 11 1/2 Inch)* in this supplement.
8. Remove the differential. Refer to *Differential Replacement (American Axle 10 1/2 Inch and 11 1/2 Inch)* in this supplement.
9. Remove the drive pinion. Refer to *Pinion Bearings Replacement (American Axle 10 1/2 Inch)* or *Pinion Bearings Replacement (American Axle 11 1/2 Inch)* in this supplement.

### Installation Procedure

1. Install the drive pinion. Refer to *Pinion Bearings Replacement (American Axle 10 1/2 Inch)* or *Pinion Bearings Replacement (American Axle 11 1/2 Inch)* in this supplement.
2. Install the differential. Refer to *Differential Replacement (American Axle 10 1/2 Inch and 11 1/2 Inch)* in this supplement.
3. Adjust the side bearing preload. Refer to *Differential Side Bearing Preload Adjustment (American Axle 10 1/2 and 11 1/2 Inch)* in this supplement.
4. Adjust the backlash. Refer to *Backlash Adjustment (American Axle 10 1/2 and 11 1/2 Inch)* in this supplement.



5. Perform a gear tooth contact pattern check. Refer to *Gear Tooth Contact Pattern Check (American Axle 10 1/2 and 11 1/2 Inch)* in this supplement.
6. Install the rear axle housing cover and gasket. Refer to *Axle Housing Cover and Gasket Replacement (American Axle 10 1/2 and 11 1/2 Inch)* in this supplement.
7. Install the brake caliper mounting plates. Refer to *Brake Caliper Mounting Plate Replacement* in the WCC Service Manual.
8. Install the hub and rotor assemblies. Refer to *Hub and Rotor Assembly* in the WCC Service Manual.
9. Install the brake calipers. Refer to *Brake Caliper Replacement (Rear)* in the WCC Service Manual for 10/1/2 inch axles or *Brake Caliper Replacement (American Axle 11 1/2 Inch)* in this supplement.
10. Install the axle shafts. Refer to *Axle Shaft Replacement (All Models)* in the WCC Service Manual for 10 1/2 inch axles or *Axle Shaft Replacement (American Axle 11 1/2 Inch)* in this supplement.
11. Install the rear axle assembly. Refer to *Axle Replacement (10 1/2 in. Ring Gear)* in the WCC Service Manual or *Axle Replacement (American Axle 11 1/2 Inch)* in this supplement.

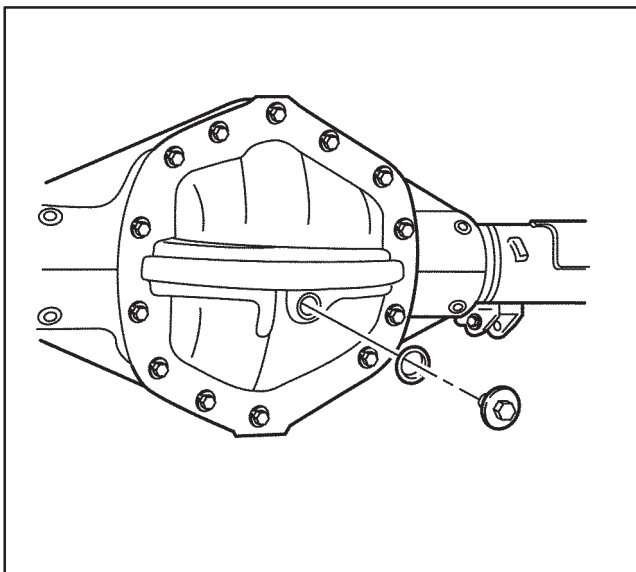

12. Remove the rear axle fill plug and seal.
13. Fill the rear axle with the proper type and quantity of lubricant. Refer to *Lubrication Specifications* and *Fluid and Lubricant Recommendations* in this supplement.

**Notice:** Refer to *Fastener Notice* in Cautions and Notices in the WCC Service Manual.

14. Install the rear axle fill plug and seal.

**Tighten**

- Tighten the rear axle fill plug to 24 N·m (18 lb ft) on 10 1/2 inch axles.
- Tighten the rear axle fill plug to 33 N·m (24 lb ft) on 11 1/2 inch axles.

15. Lower the vehicle.



## Pinion Bearings Replacement (American Axle 10 1/2 Inch)

### Tools Required

- J 8092 Driver Handle
- J 7818 Outer Pinion Bearing Cup Installer
- J 22912-01 Split Plate Bearing Puller
- J 39707 Inner Pinion Bearing Cup Installer
- J 39708 Universal Driver Handle
- J 5590 Pinion Bearing Installer

### Removal Procedure

1. Raise the vehicle. Refer to *Lifting and Jacking the Vehicle* in the WCC Service Manual.
2. Remove the tire and wheel assemblies. Refer to *Tire and Wheel Removal and Installation* in the WCC Service Manual.
3. Remove the brake calipers. Refer to *Brake Caliper Replacement (Rear)* in the WCC Service Manual.
4. Remove the brake rotors. Refer to *Hub and Rotor Replacement* in the WCC Service Manual.
5. Remove the axle shafts. Refer to *Axle Shaft Replacement (All Models)* in the WCC Service Manual.
6. Remove the differential. Refer to *Differential Replacement (American Axle 10 1/2 and 11 1/2 Inch)* in this supplement.
7. Remove the pinion. Refer to *Pinion and Ring Gear Replacement (American Axle 10 1/2 Inch)* in this supplement.
8. Press the inner bearing off of the pinion using the J22912-01 as shown.
9. Remove the selectable shim pack from the pinion.
10. Remove the pinion bearing cups using a hammer and a brass drift in the slots provided.

**Important:** Move the drift back and forth between one side of a bearing cup and the other in order to work the cup out of the housing evenly.

11. Clean and inspect all parts before assembly.

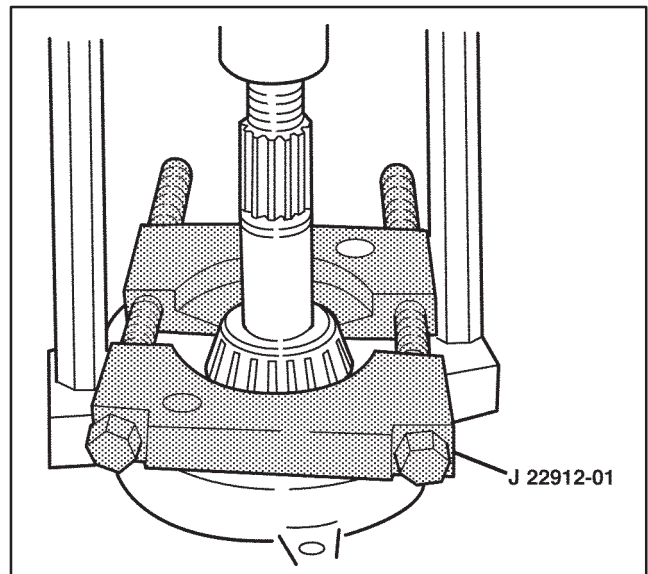

WRK42083

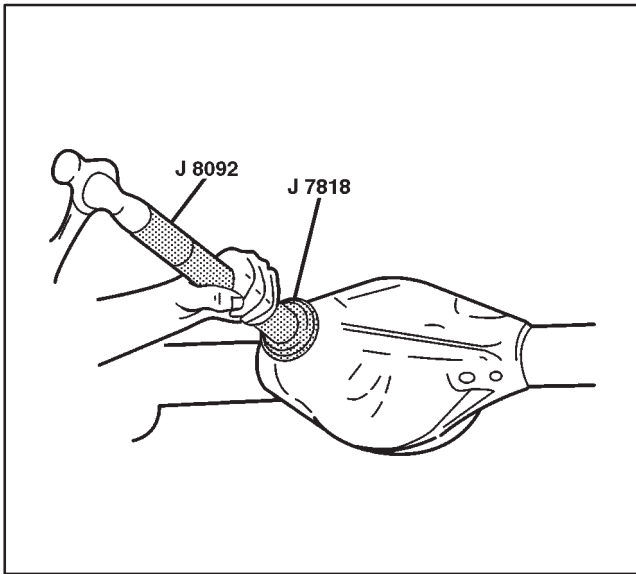

WRK42148

**Installation Procedure**

1. Install the pinion outer bearing cup using the *J 7818* and *J 8092* as shown.

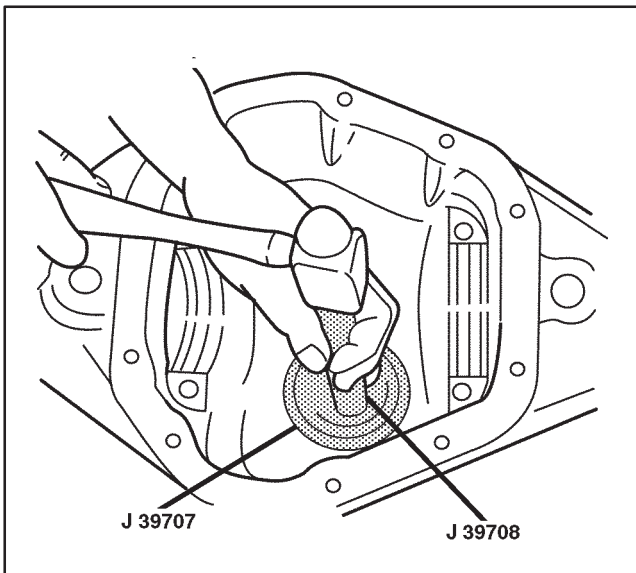

WRK42010

2. Install the pinion inner bearing cup using the *J 39707* and *J 39708* as shown.
3. Determine the selective shim thickness. Refer to *Pinion Depth Adjustment* in the WCC Service Manual.
4. Slide the selective shim pack and then the inner pinion bearing onto the pinion shaft.

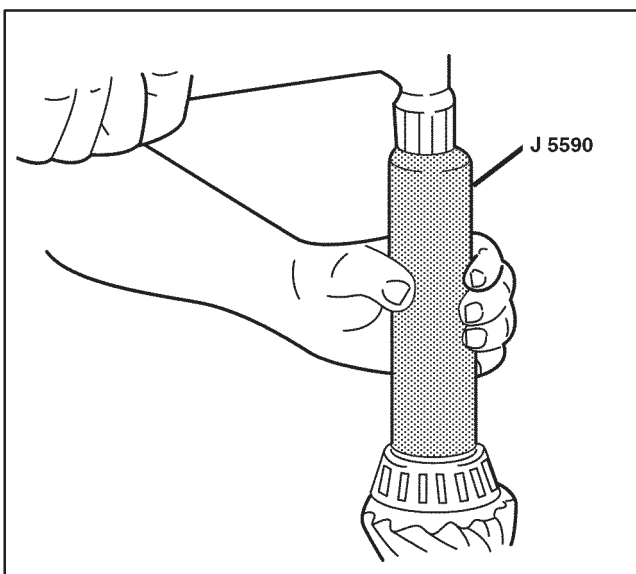

WRK42149

5. Install the pinion inner bearing using the *J 5590* as shown.

**Important:** The bearing and selective shim pack must seat against the shoulder of the gear.

6. Lubricate the pinion bearings with axle lubricant. Refer to *Fluid and Lubricant Recommendations* in this supplement.
7. Install the pinion into the rear axle housing.
8. Install the outer bearing onto the pinion shaft.
9. Install a new pinion oil seal and the pinion yoke. Refer to *Pinion Oil Seal Replacement* in the WCC Service Manual.
10. Install the differential. Refer to *Differential Replacement (American Axle 10 1/2 and 11 1/2 Inch)* in this supplement.

11. Perform a gear tooth contact pattern check. Refer to *Gear Tooth Contact Pattern Check (American Axle 10 1/2 and 11 1/2 Inch)* in this supplement.
12. Install the axle shafts. Refer to *Axle Shaft Replacement (All Models)* in the WCC Service Manual.
13. Install the brake rotors. Refer to *Hub and Rotor Replacement* in the WCC Service Manual.
14. Install the brake calipers. Refer to *Brake Caliper Replacement (Rear)* in the WCC Service Manual.
15. Install the tire and wheel assemblies. Refer to *Tire and Wheel Removal and Installation* in the WCC Service Manual.
16. Remove the rear axle fill plug and seal.
17. Fill the rear axle with the proper type and quantity of lubricant. Refer to *Lubrication Specifications and Fluid and Lubricant Recommendations* in this supplement.

**Notice:** Refer to *Fastener Notice* in Cautions and Notices in the WCC Service Manual.

18. Install the rear axle fill plug and seal.

**Tighten**

Tighten the rear axle fill plug to 24 N·m (18 lb ft).

19. Lower the vehicle.

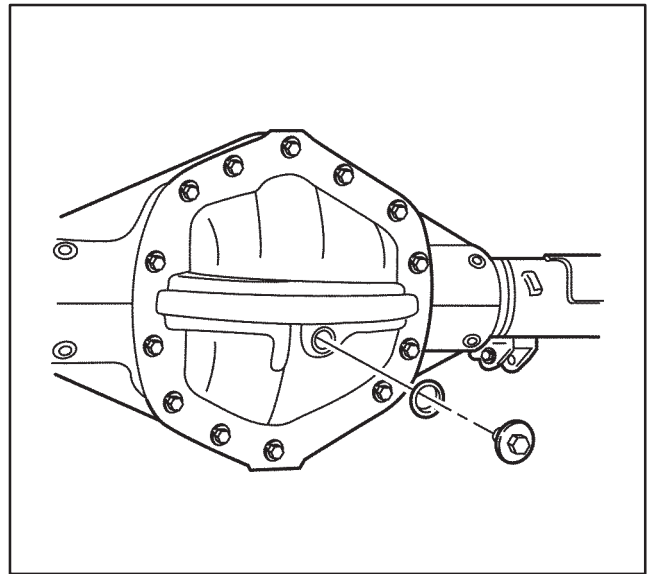

WRK42081

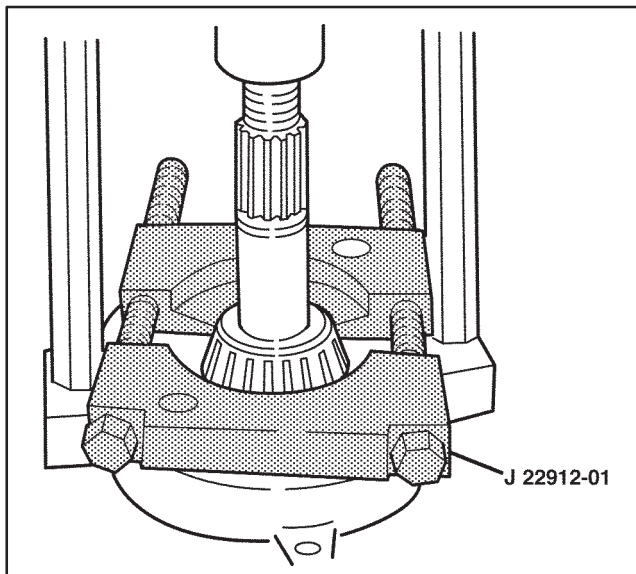

WRK42083

## Pinion Bearings Replacement (American Axle 11 1/2 Inch)

### Tools Required

- J 8092 Driver Handle
- J 8608 Outer Pinion Bearing Race Installer
- J 22912-01 Split Plate Bearing Puller
- J 44412 Pinion Bearing Installer
- J 44417 Rear Pinion Bearing Race Installer

### Removal Procedure

1. Raise the vehicle. Refer to *Lifting and Jacking the Vehicle* in the WCC Service Manual.
2. Remove the tire and wheel assemblies. Refer to *Tire and Wheel Removal and Installation* in the WCC Service Manual.
3. Remove the brake calipers. Refer to *Brake Caliper Replacement (Rear)* in the WCC Service Manual.
4. Remove the brake rotors. Refer to *Hub and Rotor Replacement* in the WCC Service Manual.
5. Remove the axle shafts. Refer to *Axle Shaft Replacement (American Axle 11 1/2 Inch)* in this supplement.
6. Remove the differential. Refer to *Differential Replacement (American Axle 10 1/2 and 11 1/2 Inch)* in this supplement.
7. Remove the pinion. Refer to *Pinion and Ring Gear Replacement (American Axle 11 1/2 Inch)* in this supplement.
8. Press the inner bearing off of the pinion using the J22912-01 as shown.
9. Remove the selectable shim from the pinion.
10. Remove the pinion bearing cups using a hammer and a brass drift in the slots provided.

**Important:** Move the drift back and forth between one side of a bearing cup and the other in order to work the cup out of the housing evenly.

11. Clean and inspect all parts before assembly.

**Installation Procedure**

1. Install the pinion outer bearing cup using the *J 8608* and *J 8092* as shown.

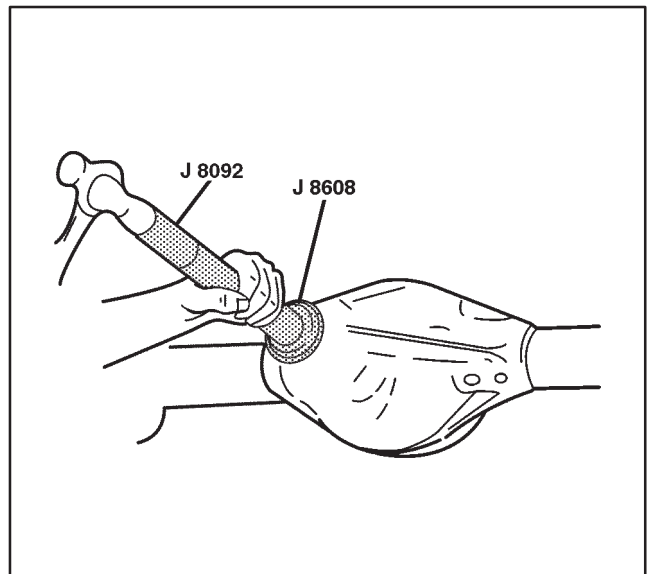

WRK42084

2. Install the pinion inner bearing cup using the *J 44417* and *J 8092* as shown.
3. Determine the selective shim thickness. Refer to *Pinion Depth Adjustment (American Axle 11 1/2 Inch)* in this supplement.
4. Slide the selective shim and then the inner pinion bearing onto the pinion shaft.

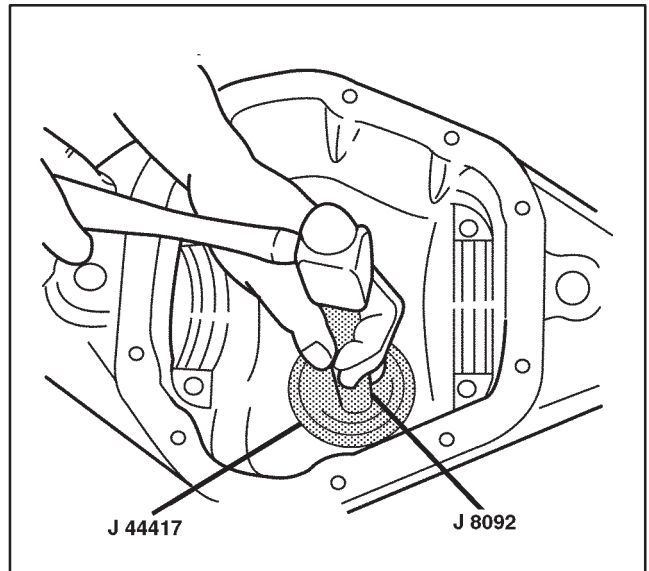

WRK42085

5. Install the pinion inner bearing using the *J 44412* as shown.

**Important:** The bearing and selective shim must seat against the shoulder on the gear.

6. Lubricate the pinion bearings with axle lubricant. Refer to *Fluid and Lubricant Recommendations* in this supplement.
7. Install the pinion into the rear axle housing.
8. Install the outer bearing onto the pinion shaft.
9. Install a new pinion oil seal and the pinion yoke. Refer to *Pinion Yoke and Oil Seal Replacement (American Axle 11 1/2 Inch)* in this supplement.
10. Install the differential. Refer to *Differential Replacement (American Axle 10 1/2 and 11 1/2 Inch)* in this supplement.

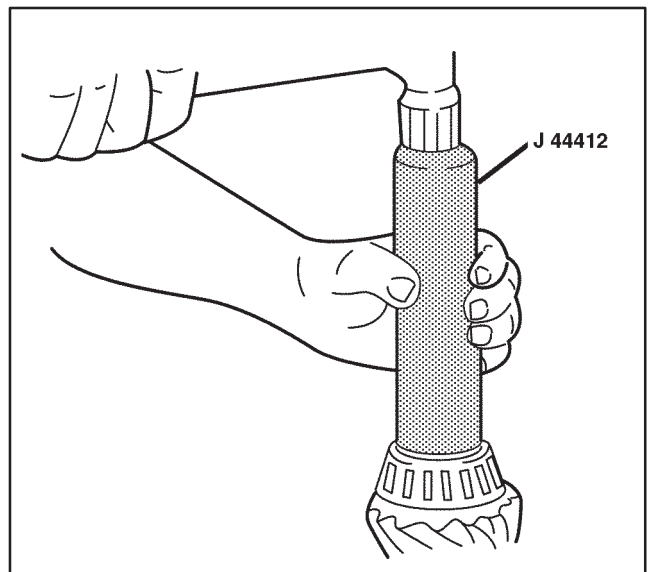

WRK42011

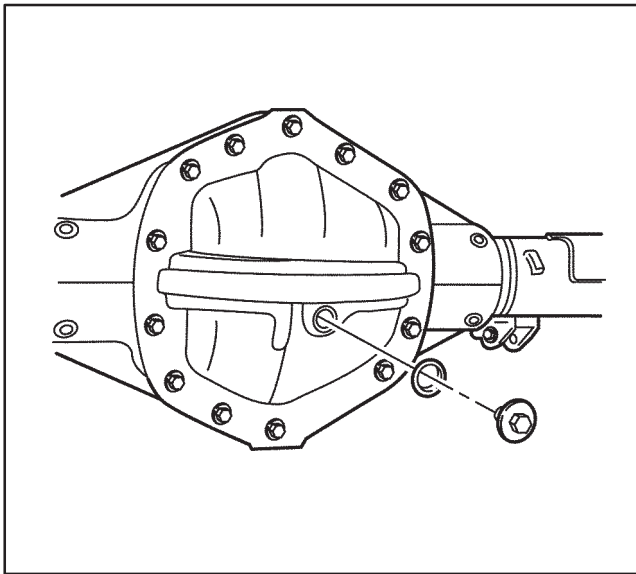

WRK42081

11. Perform a gear tooth contact pattern check. Refer to *Gear Tooth Contact Pattern Check (American Axle 11 1/2 Inch)* in this supplement.
12. Install the axle shafts. Refer to *Axle Shaft Replacement (American Axle 11 1/2 Inch)* in this supplement.
13. Install the brake rotors. Refer to *Hub and Rotor Replacement* in the WCC Service Manual.
14. Install the brake calipers. Refer to *Brake Caliper Replacement (Rear)* in the WCC Service Manual.
15. Install the tire and wheel assemblies. Refer to *Tire and Wheel Removal and Installation* in the WCC Service Manual.
16. Remove the rear axle fill plug and seal.
17. Fill the rear axle with the proper type and quantity of lubricant. Refer to *Lubrication Specifications* and *Fluid and Lubricant Recommendations* in this supplement.

**Notice:** Refer to *Fastener Notice* in Cautions and Notices in the WCC Service Manual.

18. Install the rear axle fill plug and seal.

**Tighten**

Tighten the rear axle fill plug to 33 N·m (24 lb ft).

19. Lower the vehicle.

## Pinion Bearings Replacement (Spicer Dana S135 and S150 14 Inch)

### Tools Required

- J 3453 Holding Bar
- J 7804-01 Puller
- J 22912-01 Split Plate Bearing Puller
- J 36135 Universal Bearing Cup Installer

### Removal Procedure

1. Remove the differential carrier from the rear axle housing. Refer to *Differential Carrier Replacement (Spicer Dana S135 and S150 14 Inch)* in this supplement.
2. Remove the differential case from the differential carrier. Refer to *Pinion and Ring Gear Replacement (Spicer Dana S135 and S150 14 Inch)* in this supplement.

**Important:** The use of a torque multiplier is recommended to remove the pinion nut. The torque specification on this nut is 1,220 N·m (900 lb ft).

3. Draw two arrows facing each other, one on the pinion stem and the other on the pinion yoke.
4. Hold the pinion yoke with the J 3453 and remove the pinion nut and washer.

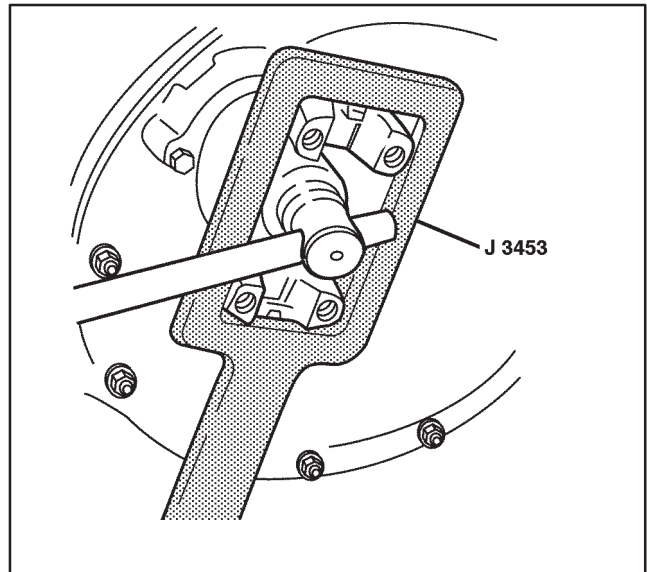

WRK42074

5. Remove the pinion yoke using the J 7804-01 as shown.

**Notice:** Be careful not to damage any machined surfaces when prying out the oil seal. Damaging the machined surfaces may cause the oil seal to leak and could result in premature component failure due to a lack of lubrication.

6. Remove the pinion oil seal using a suitable seal puller.

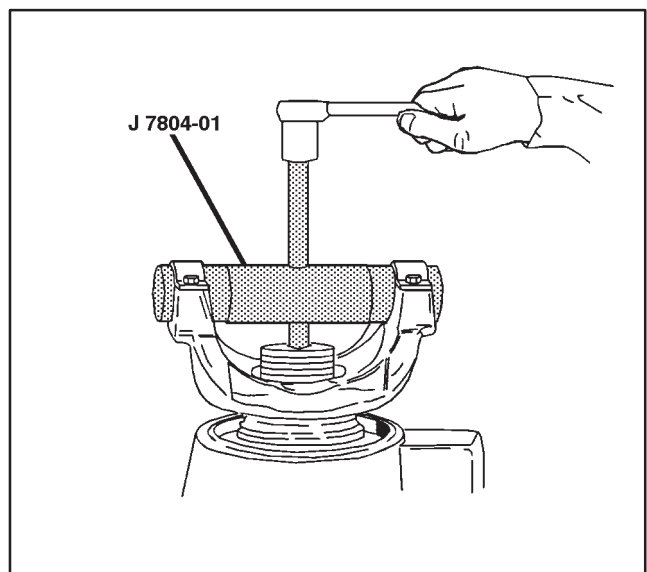

WRK42020



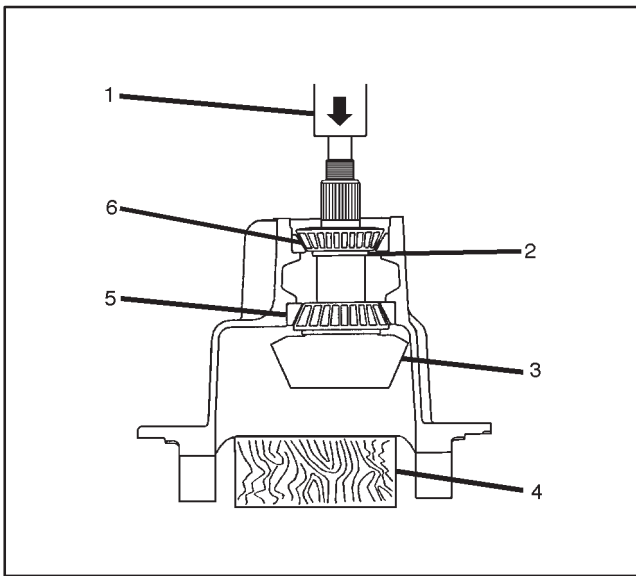

WRK42021

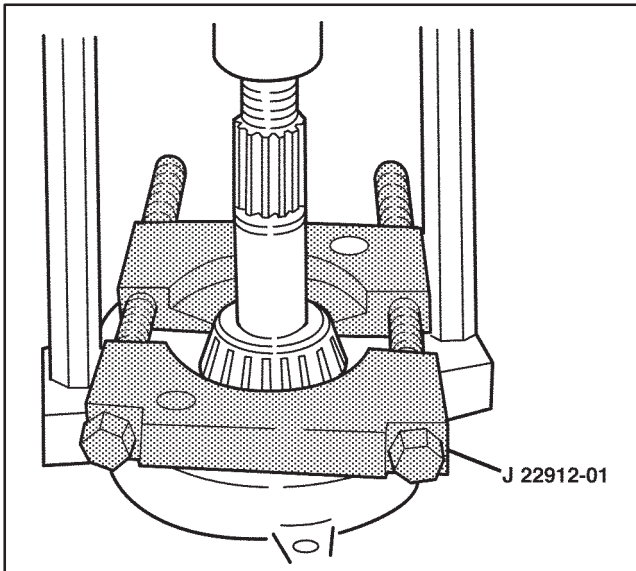

WRK42083

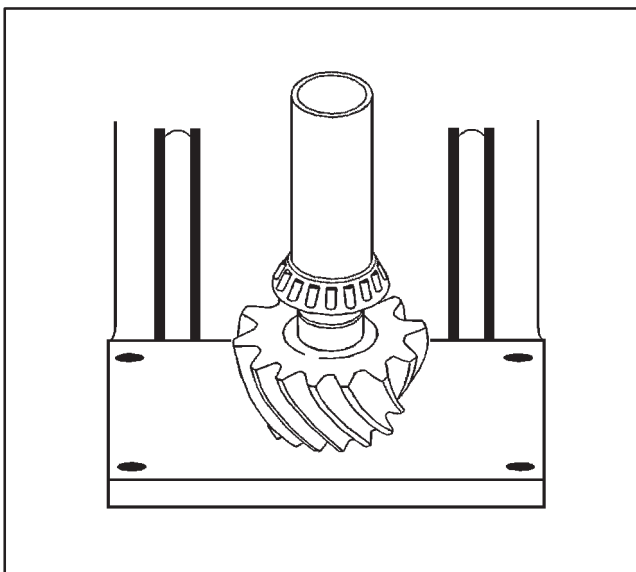

WRK42022

7. Remove the pinion from the differential carrier as follows:
  - 7.1. Position the differential carrier on a hydraulic press with the threaded end of the pinion (3) up.
  - 7.2. Place a block of wood (4) under the pinion (3) to avoid damage to the gear teeth.
  - 7.3. Press the pinion (3) through the outer pinion bearing (6) and out of the carrier.
8. Remove the bearing preload spacer (2) and save for reassembly.

9. If the gear set is to be reused, remove the inner pinion bearing using the *J 22912-01* as shown. If the gear set is being reused, new bearings must be installed.

**Important:** Move the drift back and forth between one side of a bearing cup and the other in order to work the cup out of the housing evenly.

10. Remove the pinion bearing cups using a hammer and a brass drift in the slots provided.
11. Clean and inspect all parts before assembly.

### Installation Procedure

1. Press the new inner pinion bearing onto the pinion using a universal bearing installer.
2. Press the inner and outer pinion bearing cups into the differential carrier using the *J 36135*.
3. Use a thin feeler gage (about 0.038 mm (0.0015 inch) ) to verify that the bearing cups are fully seated.
4. Lubricate the pinion bearing cups and cones with axle lubricant. Refer to *Fluid and Lubricant Recommendations* in this supplement.



5. Install the pinion, the preload spacer and the outer pinion bearing as follows:
  - 5.1. Slide the pinion (3) into the differential carrier.
  - 5.2. Place the differential carrier on a hydraulic press with the pinion (3) supported by a wood block (4).
  - 5.3. Slide the original preload spacer (2) and the outer pinion bearing (5) onto the pinion stem.
  - 5.4. Press the outer pinion bearing (5) onto the pinion stem with a suitable bearing installer until it is fully seated.
6. Inspect the pinion yoke for grooves in the sealing surface caused by contaminants. If grooves can be detected with the fingernail, the yoke must be repaired with an approved wear sleeve or replaced.

**Notice:** Do not hammer the pinion yoke onto the pinion shaft because damage to pinion components is likely to occur.

7. Using a yoke installation tool (Spicer Dana P/N DST 1009, or equivalent), install the yoke on the pinion stem without installing the pinion seal.

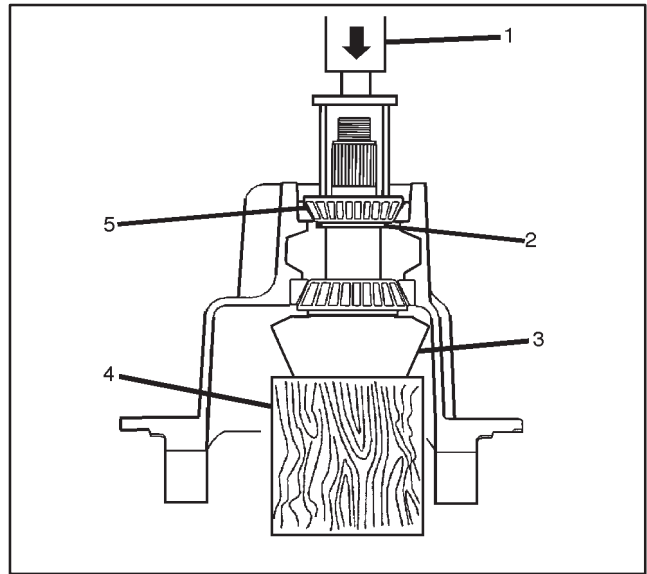

WRK42023

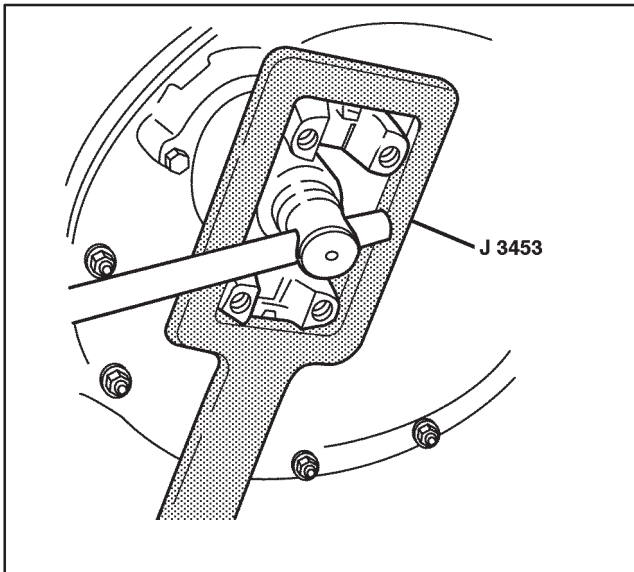

WRK42074

**Important:** The use of a torque multiplier is recommended to install the pinion nut. The torque specification on this nut is 1,220 N·m (900 lb ft).

8. Using the *J 3453*, install the pinion washer with the old pinion nut.

**Tighten**

Tighten the pinion nut to 1,220 N·m (900 lb ft).

9. Measure the turning torque of the pinion with a torque wrench. The turning torque should be from 1.1 to 4.5 N·m (10 to 40 lb in) and should be measured during every fourth revolution.
10. If the preload is higher than specified, a thinner preload spacer must be used; if the preload is lower than specified, a thicker preload spacer must be used.

**Important:** Preload spacers are available in thicknesses from 7.26 mm to 8.00 mm (0.216 in to 0.315 in). Each 0.25 mm (0.001 in) change in spacer thickness changes the turning torque by 3.4 N·m (30 lb in).

**Notice:** Closer adjustments can be made by sanding the next thicker spacer using emery cloth on a flat surface. If this method is used, the spacer must be washed thoroughly to prevent grit from entering the differential, causing premature wear of the components.

11. Repeat the process until the turning torque is within specifications, then:
  - 11.1. Hold the pinion yoke with the *J 3453* and remove the pinion nut and washer.

- 11.2. Remove the pinion yoke using the *J 7804-01*.
  12. Install a new pinion seal using a seal installer.
  13. Apply sealant (GM P/N 12346004 or equivalent) to the splines of the pinion yoke.
  14. Aligning the marks made during removal, slide the pinion yoke onto the pinion shaft.
- Notice:** Do not hammer the pinion yoke onto the pinion shaft because damage to pinion components is likely to occur.
15. Using a yoke installation tool (Spicer Dana P/N DST 1009, or equivalent), install the yoke on the pinion stem.
  16. Apply thread-locking compound (Loctite® 680, or equivalent) to the pinion threads.

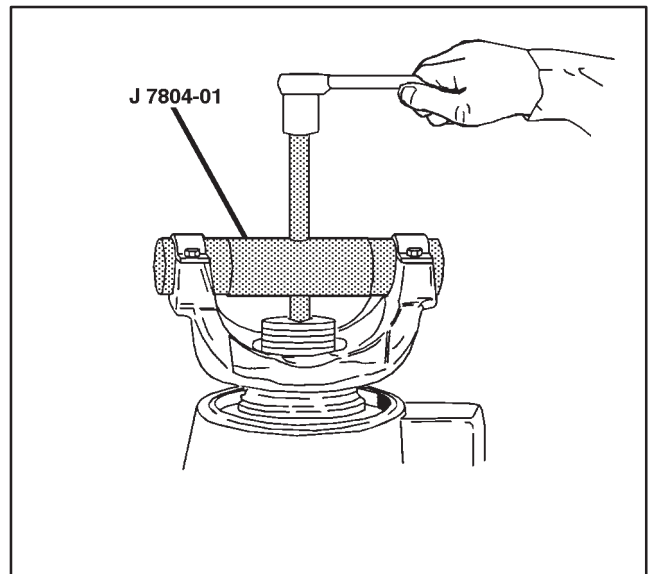

WRK42020

**Notice:** Refer to *Fastener Notice* in Cautions and Notices in the WCC Service Manual.

17. Using the *J 3453*, install the pinion washer with the new pinion nut.
- Tighten**  
Tighten the pinion nut to 1,220 N·m (900 lb ft).
18. Measure the turning torque of the pinion with a torque wrench. The turning torque with the pinion seal installed should be from 1.7 to 7.0 N·m (15 to 45 lb in) with pinion seal installed, and should be measured during every fourth revolution.
  19. Install the differential case into the carrier. Refer to *Pinion and Ring Gear Replacement (Spicer Dana S135 and S150 14 Inch)* in this supplement.
  20. Install the differential carrier to the rear axle housing. Refer to *Differential Carrier Replacement (Spicer Dana S135 and S150 14 Inch)* in this supplement.

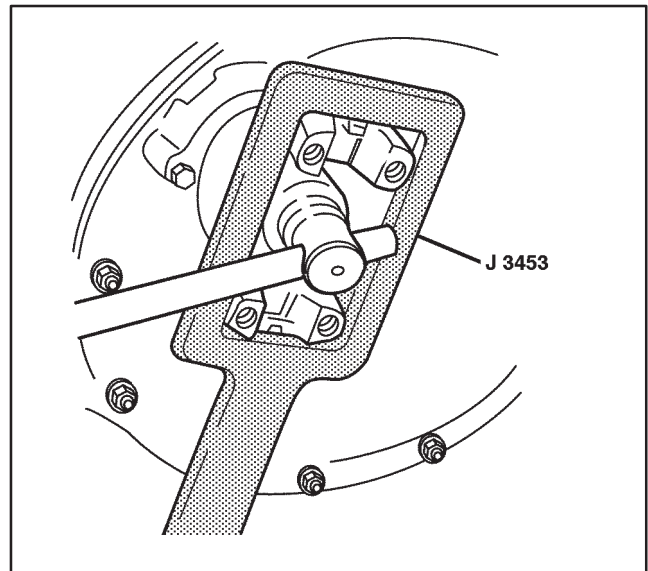

WRK42074

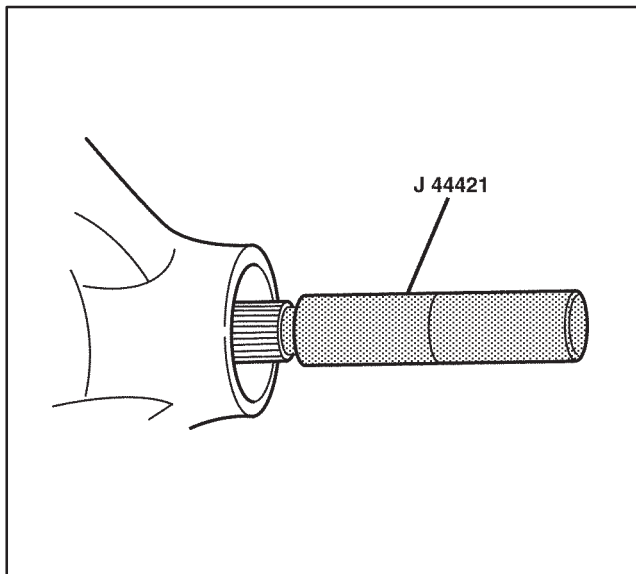

WRK42093

## Pinion and Ring Gear Replacement (American Axle 11 1/2 Inch)

### Tools Required

- J 44412 Rear Pinion Bearing Installer
- J 44421 Pinion Remover
- J 22912-01 Split Plate Bearing Puller

### Removal Procedure

1. Raise the vehicle. Refer to *Lifting and Jacking the Vehicle* in the WCC Service Manual.
2. Remove the tire and wheel assemblies. Refer to *Tire and Wheel Removal and Installation* in the WCC Service Manual.
3. Remove the brake calipers. Refer to *Brake Caliper Replacement (Rear)* in the WCC Service Manual.
4. Remove the brake rotors. Refer to *Hub and Rotor Replacement* in the WCC Service Manual.
5. Remove the axle shafts. Refer to *Axle Shaft Replacement (American Axle 11 1/2 Inch)* in this supplement.
6. Remove the differential. Refer to *Differential Replacement (American Axle 10 1/2 and 11 1/2 Inch)* in this supplement.
7. Remove the pinion yoke. Refer to *Pinion Yoke and Oil Seal Replacement (American Axle 11 1/2 Inch)* in this supplement.
8. Install the J 44421 as shown.

**Important:** Make sure that the J 44421 is fully seated on the pinion.

**Notice:** When removing the pinion, do not let the pinion fall on the ground or damage is likely to occur.

9. Drive out the pinion by tapping the J 44421 with a hammer.
10. Remove the collapsible spacer from the pinion and discard it.

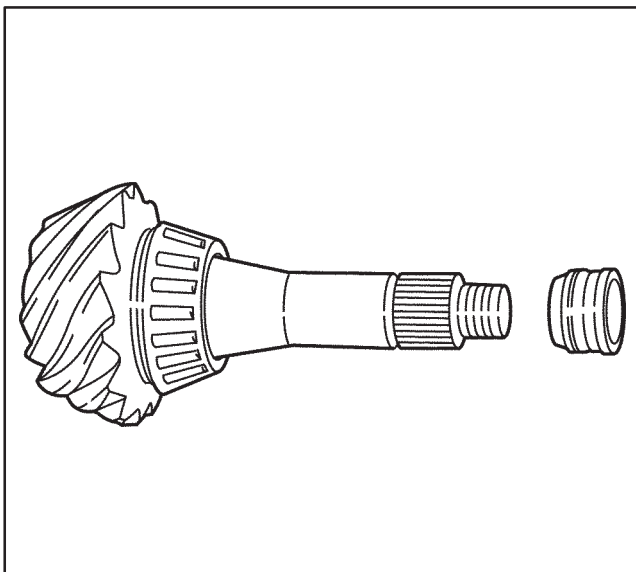

WRK42092

- Remove the pinion inner bearing and selective shims using the *J 22912-01* as shown.

**Notice:** When removing the pinion oil seal, be careful not to damage the rear axle housing.

- Remove the pinion oil seal using a suitable seal removal tool.

**Important:** When removing the pinion bearing cups, move the drift back and forth between one side of a bearing cup and the other in order to work the cup out of the housing evenly.

- Remove the pinion bearing cups using a hammer and a brass drift in the slots provided.

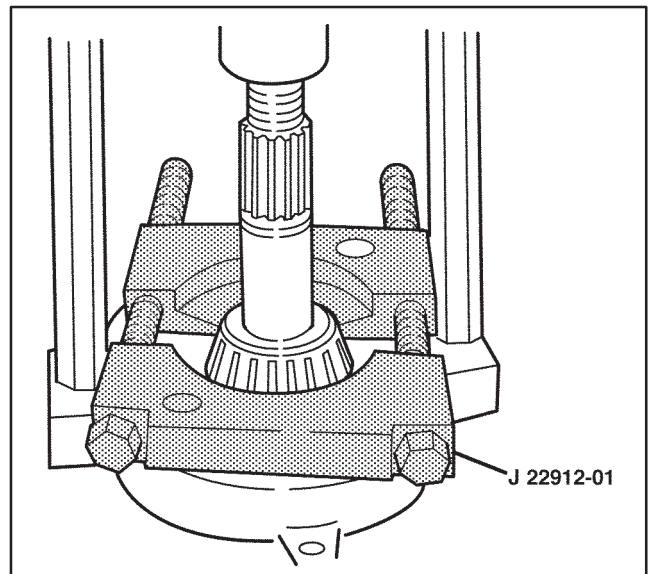

WRK42083

- Remove the ring gear bolts and discard them.

**Notice:** Do not pry the ring gear from the case. This will damage the ring gear and case. Drive the ring gear off with a hammer and brass drift, if necessary.

- Remove the ring gear from the differential case.
- Clean and inspect all parts before assembly.

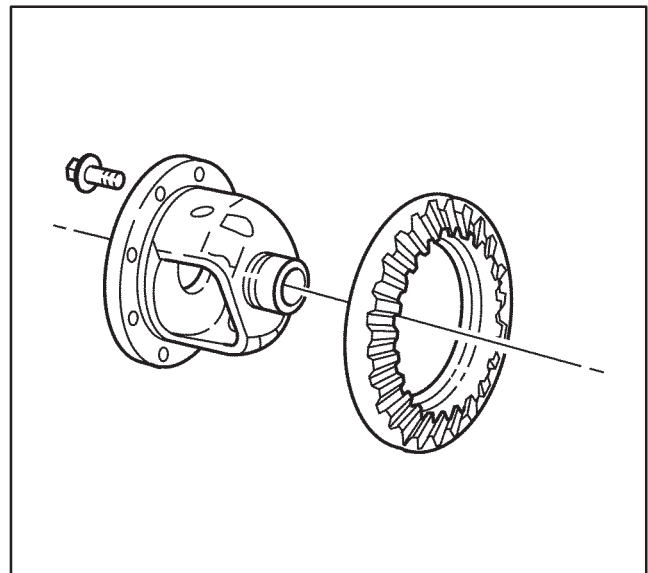

WRK42099

### Installation Procedure

**Important:** The mating surfaces of the ring gear and the differential case must be clean and free from burrs before installing the ring gear.

- Install two threaded guide studs into the ring gear on opposite sides.
- Aligning the studs with the holes in the differential case, lower the ring gear into position.

**Notice:** Refer to *Fastener Notice* in Cautions and Notices in the WCC Service Manual.

- Install new ring gear bolts and remove the guide studs.

#### Tighten

Tighten the ring gear bolts to 237 N·m (175 lb ft).

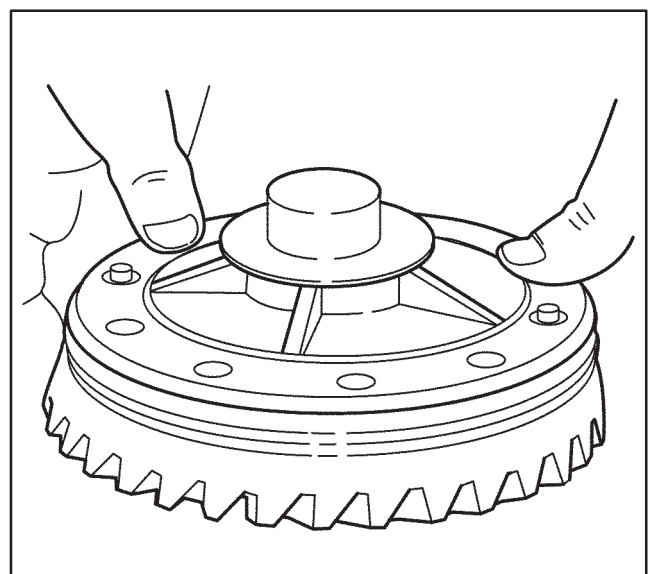

WRK42102

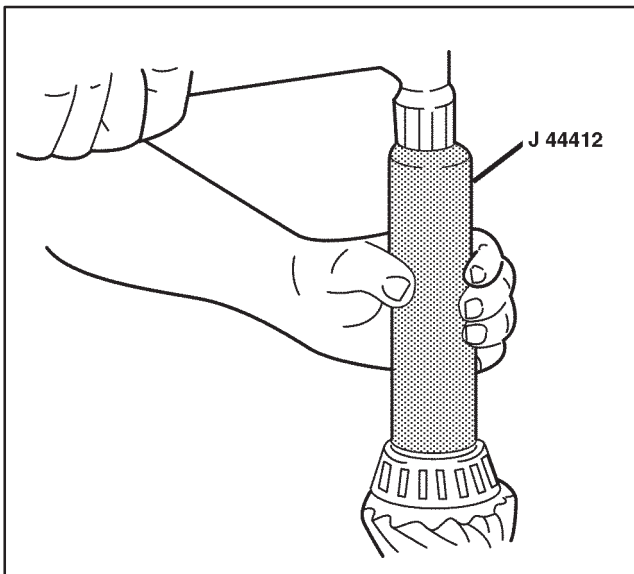

WRK42011

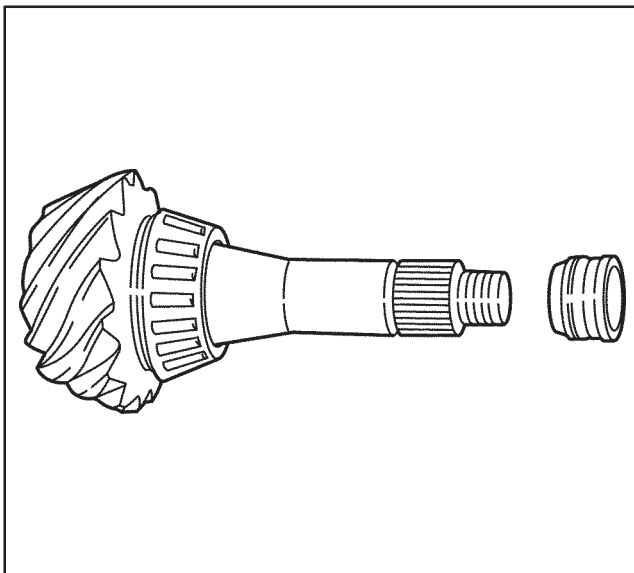

WRK42092

4. Install the Pinion Bearing Cups. Refer to *Pinion Bearings Replacement (American Axle 11 1/2 Inch)* in this supplement.
  5. Determine the selective shim thickness. Refer to *Pinion Depth Adjustment (American Axle 11 1/2 Inch)* in this supplement.
  6. Slide the selective shim and then the inner pinion bearing onto the pinion shaft.
- Important:** The bearing and selective shim must seat against the shoulder on the gear.
7. Install the pinion inner bearing using the *J 44412* as shown.

8. Install a new collapsible spacer.
9. Lubricate the pinion bearings with axle lubricant. Refer to *Fluid and Lubricant Recommendations* in this supplement.
10. Install the pinion into the rear axle housing.
11. Install the outer bearing onto the pinion shaft.
12. Install a new pinion oil seal and the pinion yoke. Refer to *Pinion Yoke and Oil Seal Replacement (American Axle 11 1/2 Inch)* in this supplement.
13. Install the differential. Refer to *Differential Replacement (American Axle 10 1/2 and 11 1/2 Inch)* in this supplement.
14. Perform a gear tooth contact pattern check. Refer to *Gear Tooth Contact Pattern Check (American Axle 11 1/2 Inch)* in this supplement.
15. Install the axle shafts. Refer to *Axle Shaft Replacement (American Axle 11 1/2 Inch)* in this supplement.
16. Install the brake rotors. Refer to *Hub and Rotor Replacement* in the WCC Service Manual.
17. Install the brake calipers. Refer to *Brake Caliper Replacement (Rear)* in the WCC Service Manual.
18. Install the tire and wheel assemblies. Refer to *Tire and Wheel Removal and Installation* in the WCC Service Manual.

19. Remove the rear axle fill plug and seal.
20. Fill the rear axle with the proper type and quantity of lubricant. Refer to *Lubrication Specifications* and *Fluid and Lubricant Recommendations* in this supplement.
21. Install the rear axle fill plug and seal.

**Tighten**

Tighten the rear axle fill plug to 33 N·m (24 lb ft).

22. Lower the vehicle.

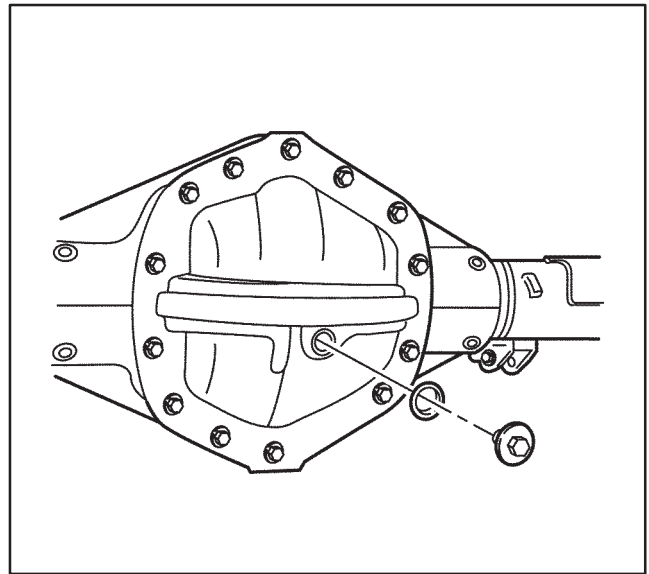

WRK42081

### Pinion and Ring Gear Replacement (Spicer Dana S135 and S150 14 Inch)

**Tools Required**

- J 3453 Holding Bar
- J 7804-01 Puller
- J 22912-01 Split Plate Bearing Puller
- J 36135 Universal Bearing Cup Installer

**Removal Procedure**

1. Remove the differential carrier from the rear axle housing. Refer to *Differential Carrier Replacement (Spicer Dana S135 and S150 14 Inch)* in this supplement.
2. Remove the differential case from the differential carrier. Refer to *Pinion and Ring Gear Replacement (Spicer Dana S135 and S150 14 Inch)* in this supplement.

**Important:** The use of a torque multiplier is recommended to remove the pinion nut. The torque specification on this nut is 1,220 N·m (900 lb ft).

3. Draw two arrows facing each other, one on the pinion stem and the other on the pinion yoke.
4. Hold the pinion yoke with the J 3453 and remove the pinion nut and washer.

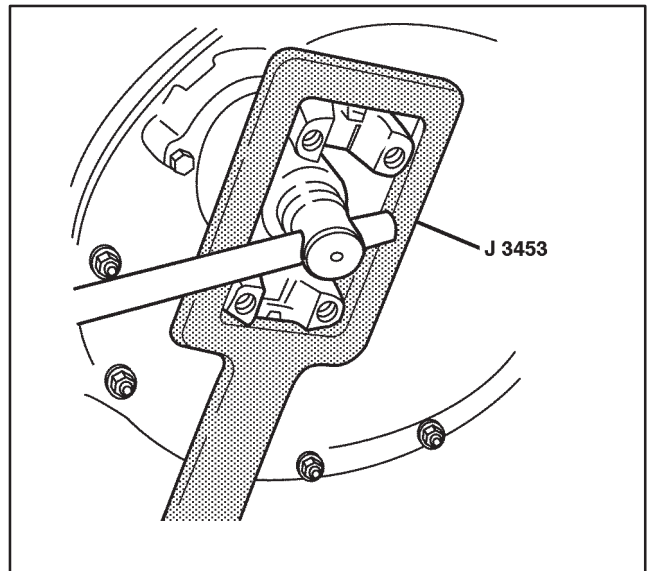

WRK42074



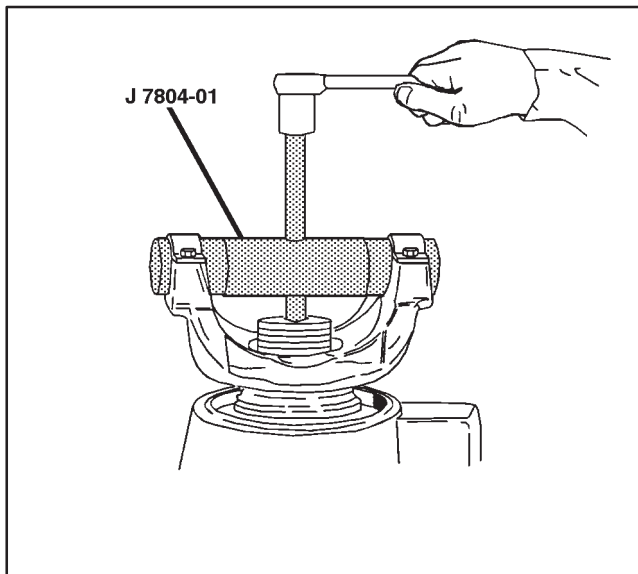

WRK42020

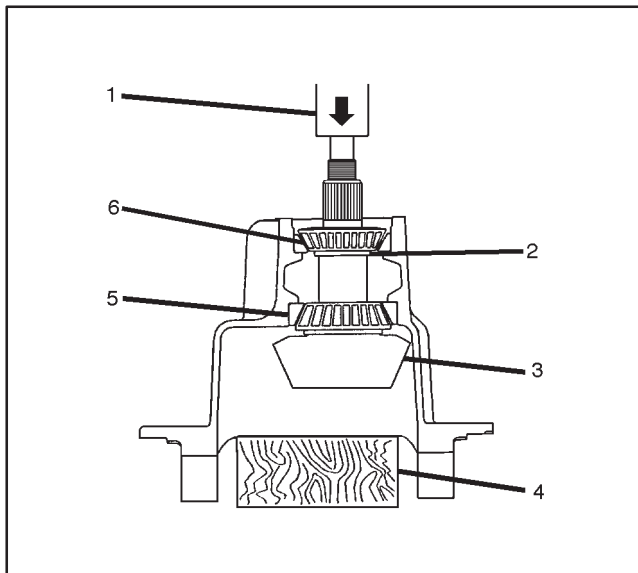

WRK42021

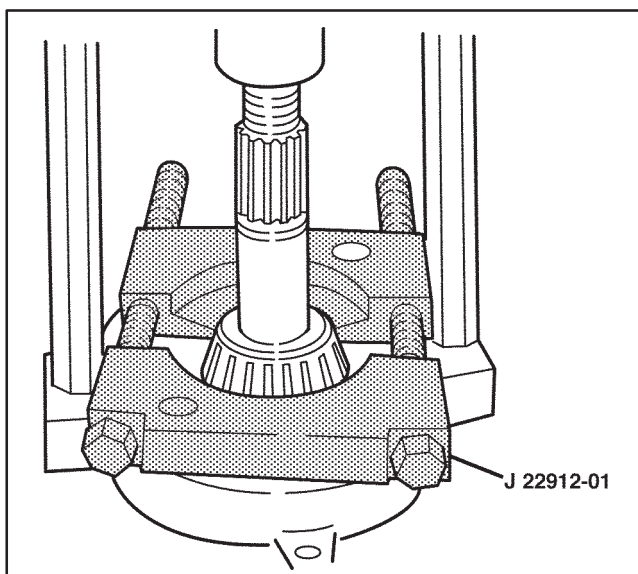

WRK42083

5. Remove the pinion yoke using the *J 7804-01* as shown.

**Notice:** Be careful not to damage any machined surfaces when prying out the oil seal. Damaging the machined surfaces may allow the oil seal to leak and could result in premature component failure due to a lack of lubrication.

6. Remove the pinion oil seal using a suitable seal puller.

7. Remove the pinion from the differential carrier as follows:

- 7.1. Position the differential carrier on a hydraulic press with the threaded end of the pinion (3) up.
- 7.2. Place a block of wood (4) under the pinion (3) to avoid damage to the gear teeth.
- 7.3. Press the pinion (3) through the outer pinion bearing (6) and out of the carrier.

8. Remove the bearing preload spacer (2) and save for reassembly.

9. If the gear set is to be reused, remove the inner pinion bearing using the *J 22912-01* as shown. If the gear set is being reused, new bearings must be installed.

**Important:** Move the drift back and forth between one side of a bearing cup and the other in order to work the cup out of the housing evenly.

10. Remove the pinion bearing cups using a hammer and a brass drift in the slots provided.



**Notice:** Do not use a chisel to remove the ring gear rivet heads or damage to the differential case is likely to occur.

11. Remove the ring gear (1) from the differential case (2) as follows:
  - 11.1. Carefully center punch each rivet head using a soft face or heavy duty plastic hammer.
  - 11.2. Using a 9/16 inch drill bit, carefully drill through each rivet as shown.
  - 11.3. Using a rounded punch, drive out the remaining portion of the rivets.
12. Clean and inspect all parts before assembly.

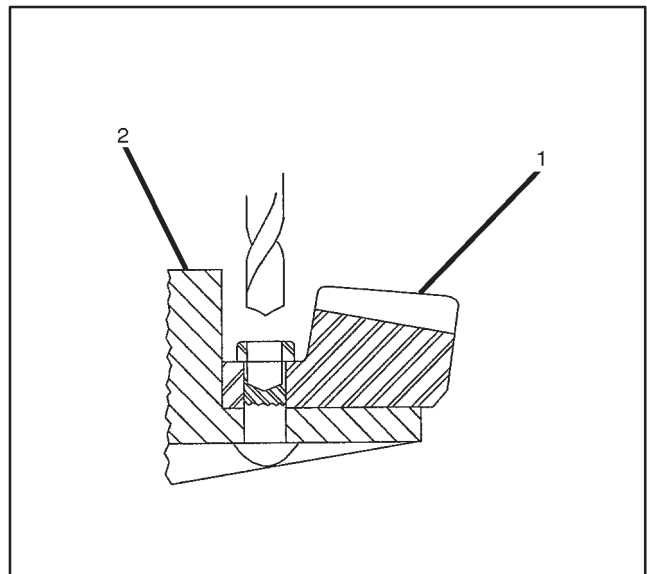

WRK42031

### Installation Procedure

1. Position the ring gear on the differential case with the rivet holes aligned.

**Notice:** Refer to *Fastener Notice* in Cautions and Notices in the WCC Service Manual.

2. Install new ring gear to case rivets.
3. Press the new inner pinion bearing onto the pinion using a universal bearing installer.
4. Press the inner and outer pinion bearing cups into the differential carrier using the *J 36135*.
5. Use a thin feeler gage (about 0.038 mm (0.0015 inch) ) to verify that the bearing cups are fully seated.
6. Lubricate the pinion bearing cups and cones with axle lubricant. Refer to *Fluid and Lubricant Recommendations* in this supplement.

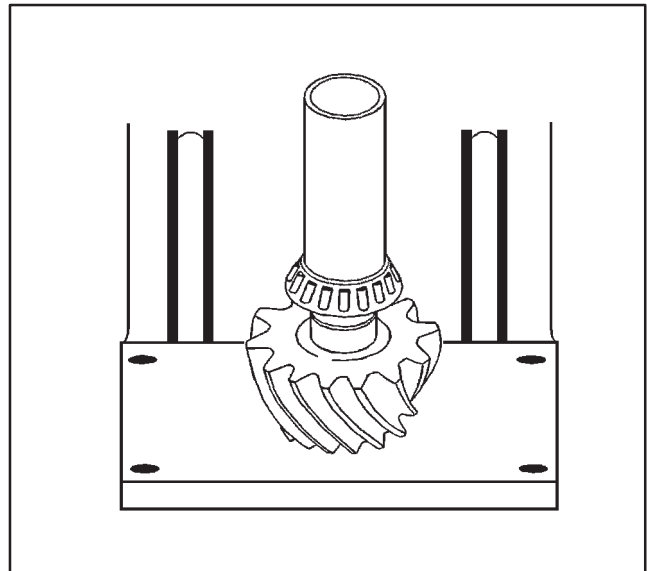

WRK42022

7. Install the pinion, the preload spacer and the outer pinion bearing as follows:
  - 7.1. Slide the pinion (3) into the differential carrier.
  - 7.2. Place the differential carrier on a hydraulic press with the pinion (3) supported by a wood block (4).
  - 7.3. Slide the original preload spacer (2) and the outer pinion bearing (5) onto the pinion stem.
  - 7.4. Press the outer pinion bearing (5) onto the pinion stem with a suitable bearing installer until it is fully seated.
8. Inspect the pinion yoke for grooves in the sealing surface caused by contaminants. If grooves can be detected with the fingernail, the yoke must be repaired with an approved wear sleeve or replaced.

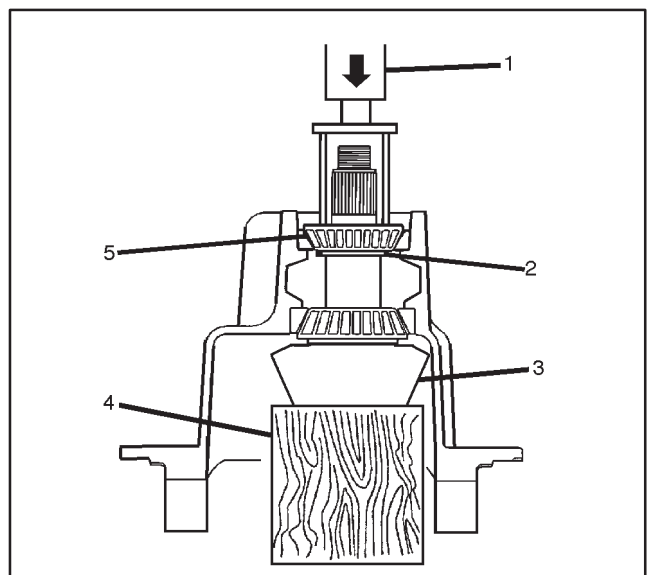

WRK42023

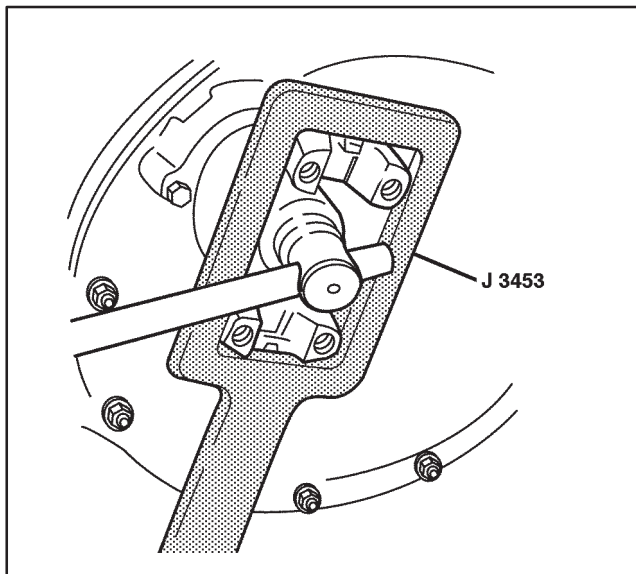

WRK42074

**Notice:** Do not hammer the pinion yoke onto the pinion shaft because damage to pinion components is likely to occur.

9. Using a yoke installation tool (Spicer Dana P/N DST 1009, or equivalent), install the yoke on the pinion stem without installing the pinion seal.

**Important:** The use of a torque multiplier is recommended to install the pinion nut. The torque specification on this nut is 1,220 N·m (900 lb ft).

10. Install the pinion washer with the old pinion nut.

#### Tighten

Tighten the pinion nut to 1,220 N·m (900 lb ft).

11. Measure the turning torque of the pinion with a torque wrench. The turning torque should be from 1.1 to 4.5 N·m (10 to 40 lb in) and should be measured during every fourth revolution.
12. If the preload is higher than specified, a thinner preload spacer must be used; if the preload is lower than specified, a thicker preload spacer must be used.

**Important:** Preload spacers are available in thicknesses from 7.26 mm to 8.00 mm (0.216 in to 0.315 in). Each 0.025 mm (0.001 in) change in spacer thickness changes the turning torque by 3.4 N·m (30 lb in).

**Notice:** Closer adjustments can be made by sanding the next thicker spacer using emery cloth on a flat surface. If this method is used, the spacer must be washed thoroughly to prevent grit from entering the differential, causing premature wear of the components.

13. Repeat the process until the turning torque is within specifications, then:
  - 13.1. Hold the pinion yoke with the *J 3453* and remove the pinion nut and washer.

- 13.2. Remove the pinion yoke using the *J 7804-01*.

14. Install a new pinion seal using a seal installer.
15. Apply sealant (GM P/N 12346004 or equivalent) to the splines of the pinion yoke.
16. Aligning the marks made during removal, slide the pinion yoke onto the pinion shaft.

**Notice:** Do not hammer the pinion yoke onto the pinion shaft because damage to pinion components is likely to occur.

17. Using a yoke installation tool (Spicer Dana P/N DST 1009, or equivalent), install the yoke on the pinion stem.
18. Apply thread-locking compound (Loctite® 680, or equivalent) to the pinion threads.

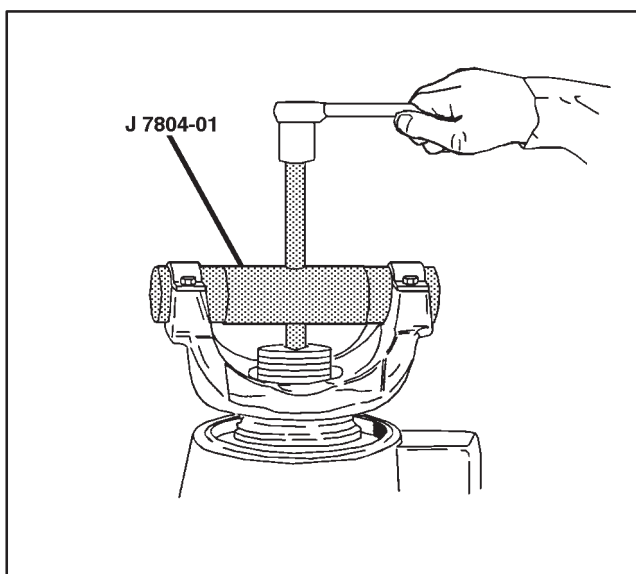

WRK42020

- Using the *J 3453*, install the pinion washer with the new pinion nut.

**Tighten**

Tighten the pinion nut to 1,220 N·m (900 lb ft).

- Measure the turning torque of the pinion with a torque wrench. The turning torque with the pinion seal installed should be from 1.7 to 7.0 N·m (15 to 45 lb in) with pinion seal installed, and should be measured during every fourth revolution.
- Install the differential case into the carrier. Refer to *Differential Carrier Replacement (Spicer Dana S135 and S150 14 Inch)* in this supplement.
- Adjust the pinion to ring gear backlash. Refer to *Backlash Adjustment (Spicer Dana S135 and S150 14 Inch)* in this supplement.
- Perform a gear tooth contact pattern check. Refer to *Gear Tooth Contact Pattern Check (Spicer Dana S135 and S150 14 Inch)* in this supplement.
- Install the differential carrier to the rear axle housing. Refer to *Differential Carrier Replacement (Spicer Dana S135 and S150 14 Inch)* in this supplement.

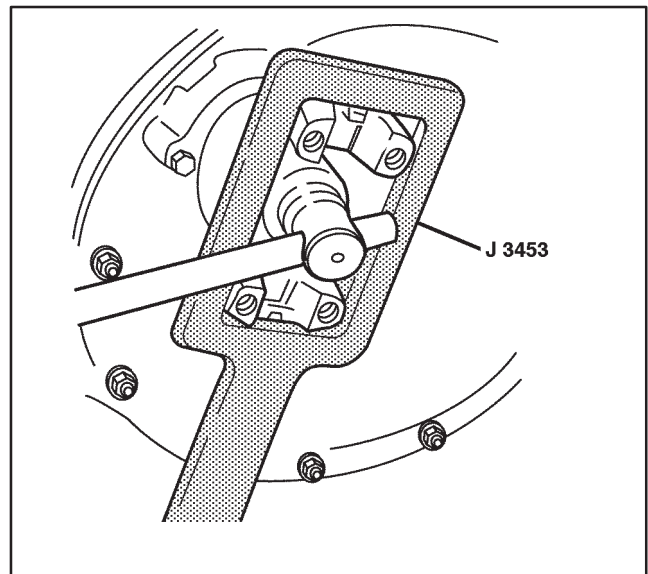

WRK42074

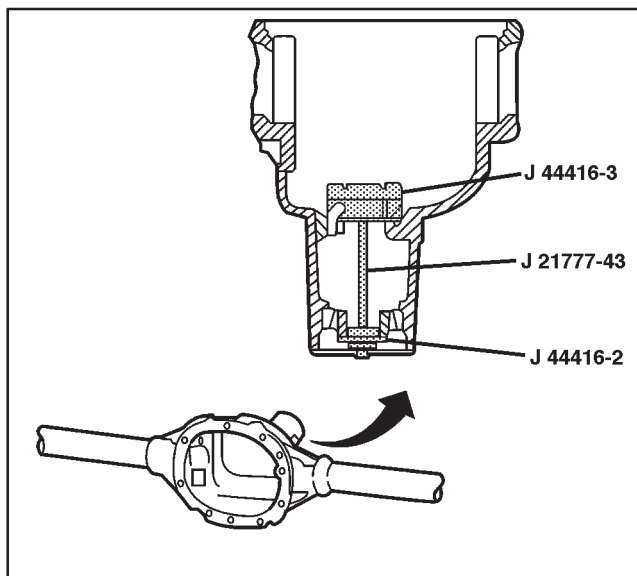

WRK42090

## Pinion Depth Adjustment (American Axle 11 1/2 Inch)

### Tools Required

- J 44416 Pinion Setting Adapter Kit Consisting of:
  - J 44416-1 Disc
  - J 44416-2 Centering Washer
  - J 44416-3 Gauge Plate
- J 21777-1 Pinion Setting Component
- J 21777-43 Stud Assembly Bolt
- J 8001 Dial Indicator Set

**Important:** Make sure that all tools, the differential side bearing bores, and the pinion cups are clean before proceeding.

1. Lubricate the pinion bearings with axle lubricant. Refer to *Fluid and Lubricant Recommendations* in this supplement.
2. Install the pinion bearings into the rear axle housing.
3. Assemble the J 44416-2, the J 44416-3, and the J 21777-43 into the axle housing as shown.
4. Hold the J 21777-43 steady and tighten the nut with an inch-pound torque wrench until a rotating torque of 2.3 N · m (20 lb in) is obtained.
5. Rotate the assembly several times in both directions to seat the pinion bearings.
6. Check the rotating torque of the assembly again.
7. If the rotating torque is less than 1.7 N · m (15 lb in), tighten the nut on the J 21777-43 until a rotating torque of 1.7 to 2.8 N · m (15 to 25 lb in) is obtained.

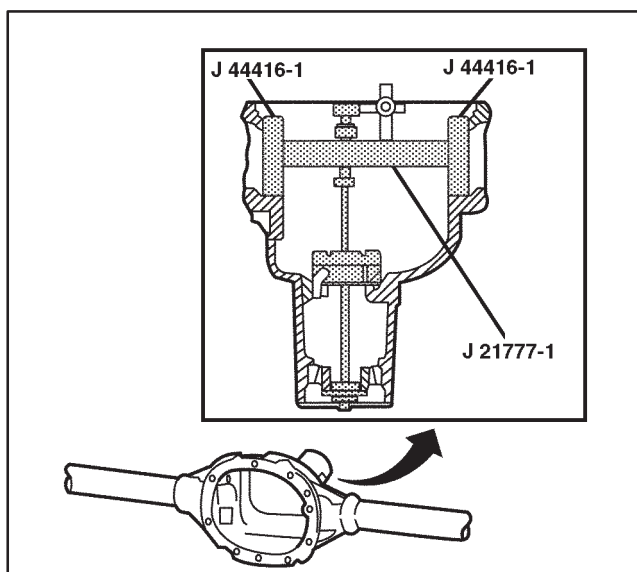

WRK42095

8. Assemble the J 44416-1 to the J 21777-1 as shown.

**Notice:** Refer to *Fastener Notice* in Cautions and Notices in the WCC Service Manual.

9. Install the differential side bearing caps and mounting bolts.

### Tighten

Tighten the bearing cap mounting bolts to 75 N · m (55 lb ft).

10. Rotate the J 21777-1 inside of the J 44416-1 to ensure that it turns freely.

**Important:** If the J 21777-1 does not rotate freely, disassemble the components, inspect for proper seating and proper alignment of components, then reassemble the components.

11. Align the plunger of the *J 21777-1* to the *J 44416-3* as shown.

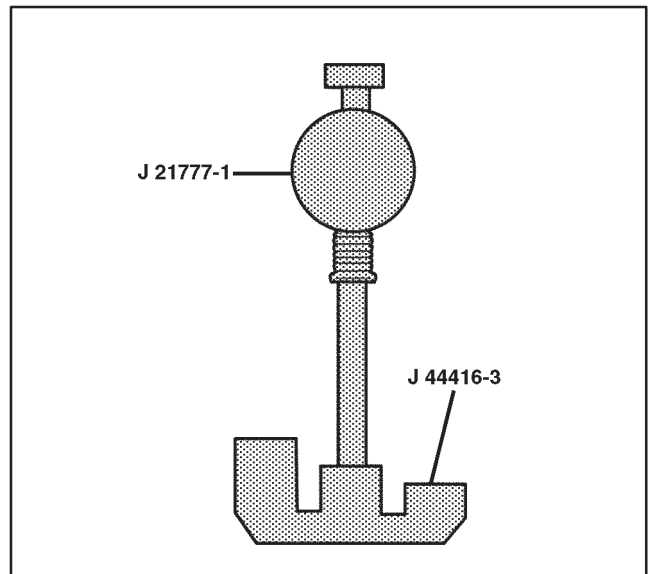

WRK42101

12. Install the *J 8001* to the *J 21777-1* as follows:
- 12.1. Loosely clamp the *J 8001* onto the stem of the *J 21777-1*.
  - 12.2. Place the contact pad of the *J 8001* onto the mounting post of the *J 21777-1*.
  - 12.3. With the contact pad of the *J 8001* touching the mounting post of the *J 21777-1*, loosen the lock nut and push down the *J 8001* until the needle on the dial face has turned 3/4 of a turn clockwise.
  - 12.4. Tighten the clamp on the *J 8001* finger tight.
13. Move the plunger of the *J 21777-1* back and forth until the needle of the *J 8001* indicates the greatest deflection.

**Important:** The deflection is the point where the needle changes direction.

14. At the greatest point of deflection, turn the housing on the *J 8001* until the needle on the dial face indicates zero.
15. Move the plunger of the *J 21777-1* back and forth again to verify the zero setting.
16. Adjust the housing on the *J 8001*, if necessary, to reestablish a zero indication.
17. Rotate the plunger of the *J 21777-1* away from the *J 44416-3* until it is no longer touching.
18. The reading on the dial face of the *J 8001* indicates the thickness of the shims needed to correctly set the depth of the pinion.
19. Select the shim that is the thickness indicated on the dial face of the *J 8001*.
20. Remove all of the pinion depth setting tools.
21. Remove the pinion bearings and install the pinion shim between the pinion gear rear face and the inner pinion bearing. Refer to *Pinion Bearings Replacement (American Axle 10 1/2 and 11 1/2 Inch)* in this supplement.

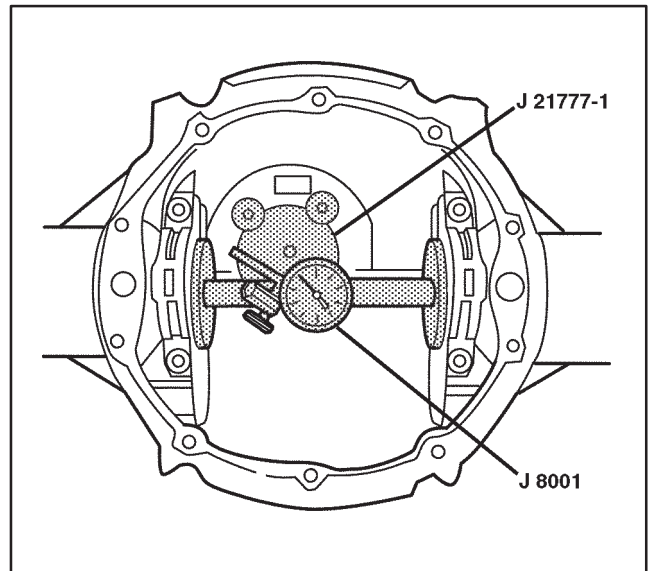

WRK42096

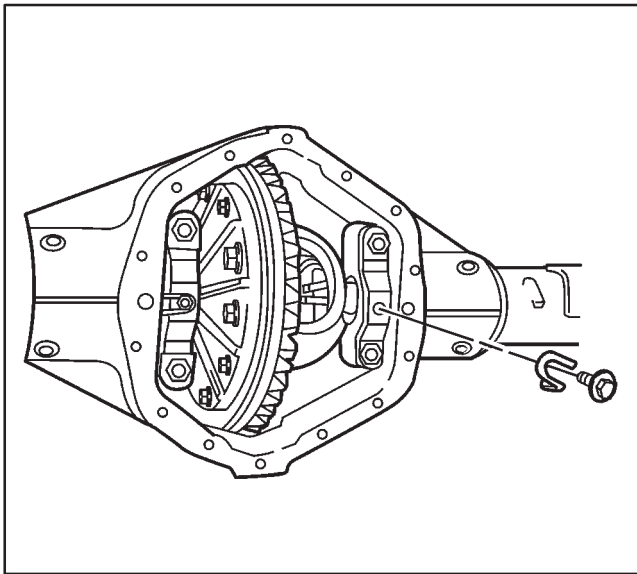

WRK42087

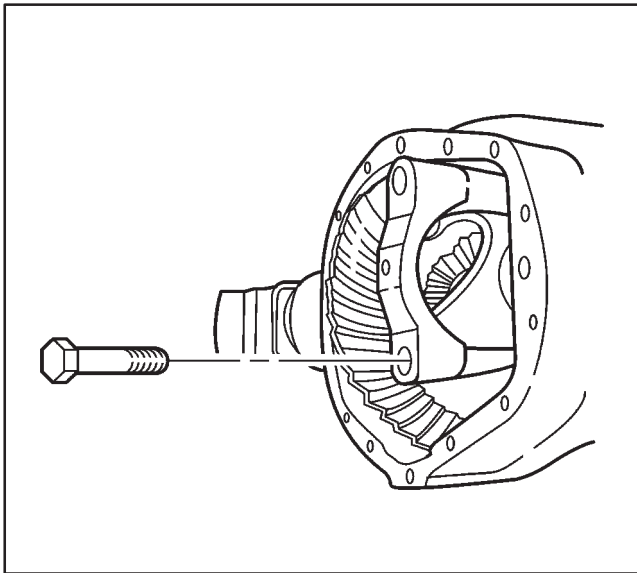

WRK42088

### Differential Replacement (American Axle 10 1/2 and 11 1/2 Inch)

#### Tools Required

*J 24429* Side Bearing Nut Wrench

1. Raise the vehicle. Refer to *Lifting and Jacking the Vehicle* in the WCC Service Manual.
2. Remove the axle shafts. Refer to *Axle Shaft Replacement (All Models)* in the WCC Service Manual for 10 1/2 inch axles or *Axle Shaft Replacement (American Axle 11 1/2 Inch)* in this supplement.
3. Remove the rear axle housing cover and gasket. Refer to *Rear Axle Housing Cover and Gasket Replacement (American Axle 10 1/2 and 11 1/2 Inch)* in this supplement.
4. Remove the differential bearing adjuster nut lock bolts.
5. Remove the differential bearing adjuster nut locks.
6. Remove the bearing caps and mounting bolts.
7. Mark the bearing caps left and right.

8. Loosen the differential bearing adjusters using the J 24429.

**Caution:** To prevent personal injury and component damage, support the differential case when removing it from the housing. If the case is not supported, it could fall and cause personal injury or component damage.

**Notice:** When removing the differential be careful not to damage the cover gasket surfaces. If the surfaces are damaged, lubricant may leak out and cause premature failure of the axle assembly components.

9. Remove the differential case from the rear axle housing.
10. Remove the bearing cups and spacers.
11. Mark the bearing cups and spacers as left and right.
12. Place the bearing cups and spacers with their respective bearing caps.
13. Remove the differential side bearings if they are to be reused. Refer to *Differential Overhaul (American Axle 10 1/2 and 11 1/2 Inch)* in this supplement.
14. Remove the ring gear if it is to be reused. Refer to *Differential Overhaul (American Axle 10 1/2 and 11 1/2 Inch)* in this supplement.

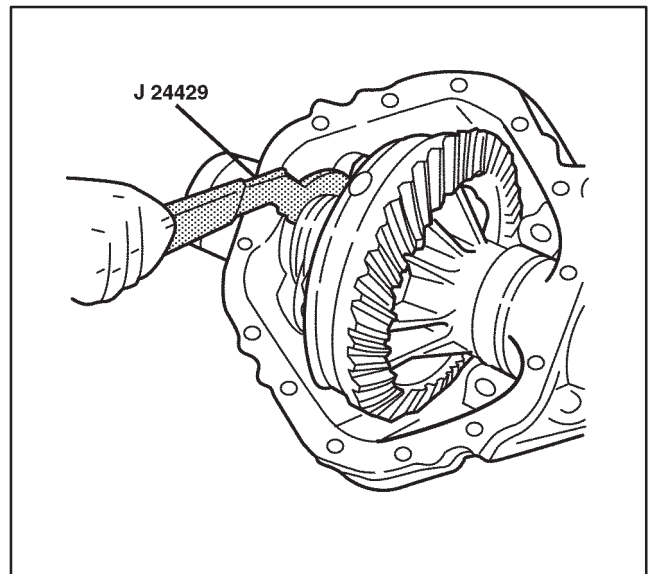

WRK42091



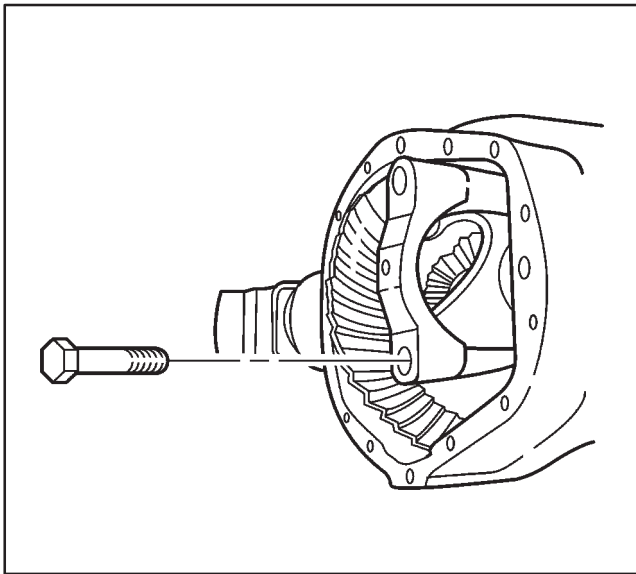

WRK42088

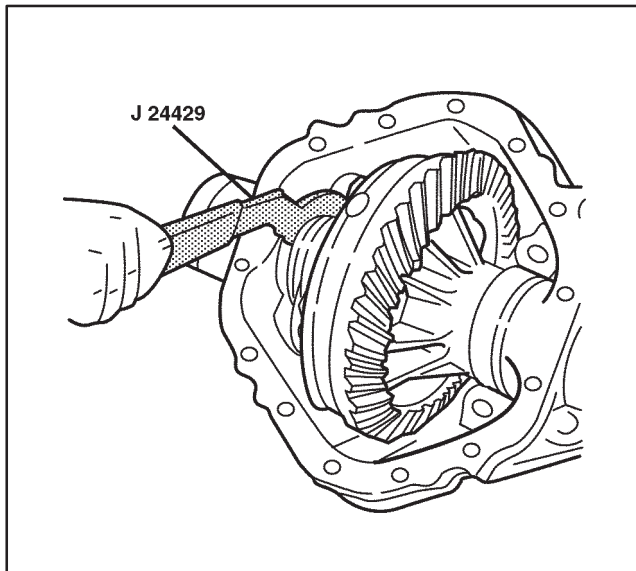

WRK42091

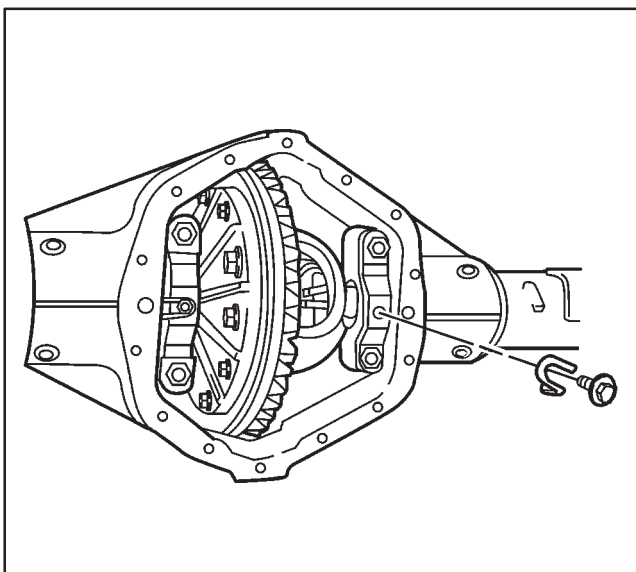

WRK42087

### Installation Procedure

1. Install the ring gear. Refer to *Differential Overhaul (American Axle 10 1/2 and 11 1/2 Inch)* in this supplement.
2. Install the differential side bearings. Refer to *Differential Overhaul (American Axle 10 1/2 and 11 1/2 Inch)* in this supplement.
3. Install the differential bearing adjusters.
4. Lubricate the differential side bearings with axle lubricant. Refer to *Fluid and Lubricant Recommendations* in this supplement.
5. Place the differential case, with the bearing cups installed, into the rear axle housing.

**Notice:** Refer to *Fastener Notice* in Cautions and Notices in the WCC Service Manual.

6. Install the bearing caps and the bearing cap mounting bolts. Do not torque the bearing cap bolts at this time.
7. Tighten the differential side bearing adjusters using the *J 24429* until they are snug against the differential bearing cups.
8. Adjust the backlash. Refer to *Backlash Adjustment (American Axle 10 1/2 and 11 1/2 Inch)* in this supplement.
9. Perform a gear tooth contact pattern check. Refer to *Gear Tooth Contact Pattern Check (American Axle 10 1/2 and 11 1/2 Inch)* in this supplement.

10. Install the differential adjusting nut locks.
11. Install the differential adjusting nut lock bolts.

#### Tighten

Tighten the differential adjusting nut lock bolts to 27 N·m (20 lb ft).

12. Install the rear axle housing cover and a new gasket. Refer to *Rear Axle Housing Cover and Gasket Replacement (American Axle 10 1/2 and 11 1/2 Inch)* in this supplement.
13. Install the axle shafts. Refer to *Axle Shaft Replacement* in the WCC Service Manual for 10 1/2 inch axles or *Axle Shaft Replacement (American Axle 11 1/2 Inch)* in this supplement.



14. Remove the rear axle fill plug and seal.
15. Fill the rear axle with the proper type and quantity of lubricant. Refer to *Lubrication Specifications* and *Fluid and Lubricant Recommendations* in this supplement.
16. Install the rear axle fill plug and seal.

**Tighten**

- Tighten the rear axle fill plug to 24 N·m (18 lb ft) on 10 1/2 inch axles.
  - Tighten the rear axle fill plug to 33 N·m (24 lb ft) on 11 1/2 inch axles.
17. Lower the vehicle.

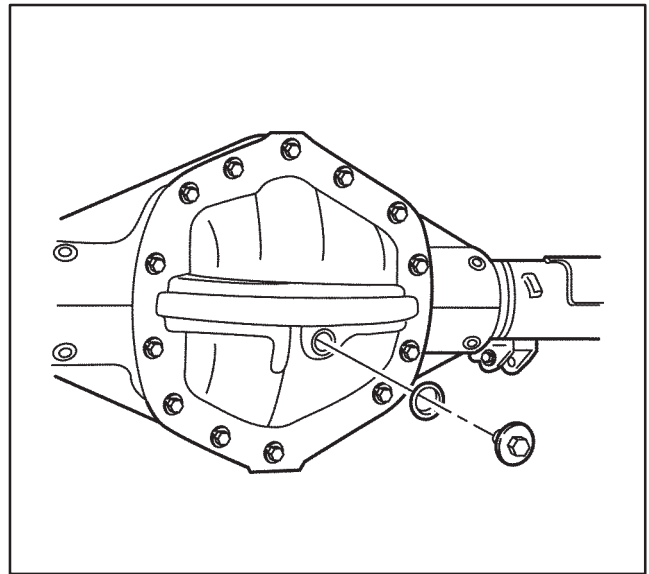

WRK42081

### Differential Replacement (Spicer Dana S135 and S150 14 Inch)

**Tools Required**

*J 22912-01* Split Plate Bearing Puller

**Important:** In order to remove the maximum amount of foreign material and contaminants, always drain the rear axle lubricant when it is at its normal operating temperature.

**Removal Procedure**

1. Raise the vehicle. Refer to *Lifting and Jacking the Vehicle* in the WCC Service Manual.
2. Place a suitable container under the rear axle housing cover to catch draining lubricant.
3. Remove the rear axle drain plug and let the lubricant drain into the container.

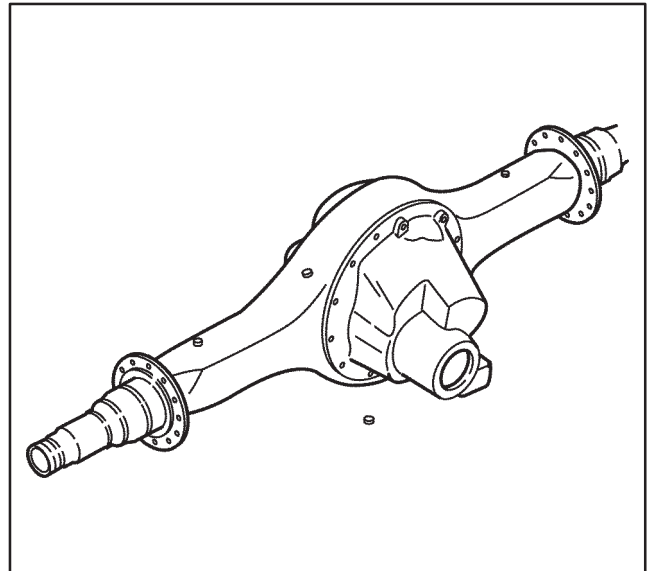

WRK42014

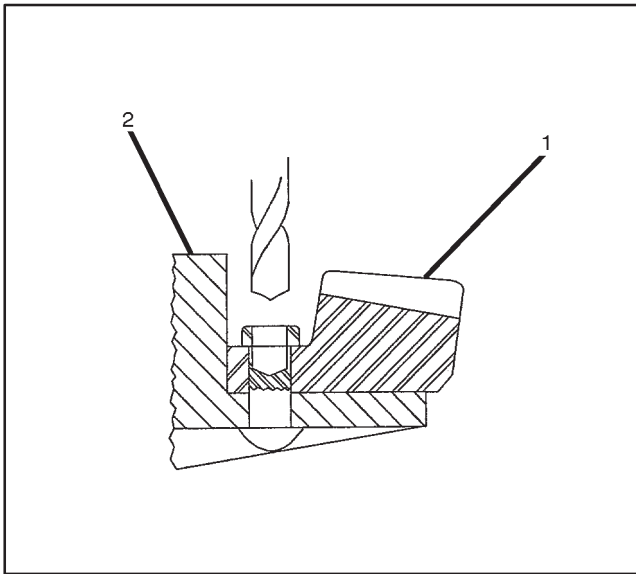

WRK42031

4. Disconnect the propeller shaft. Refer to *Three Piece Propeller Shaft Replacement* in the WCC Service Manual.
5. Remove the axle shafts. Refer to *Axle Shaft Replacement (Spicer Dana S135 and S150 14 Inch)* in this supplement.
6. Remove the differential carrier from the rear axle housing. Refer to *Differential Carrier Replacement (Spicer Dana S135 and S150 14 Inch)* in this supplement.
7. With the differential carrier installed in a suitable fixture, remove the adjusting ring lock bolts and the adjusting ring locks.
8. Match mark the differential side bearing caps for ease of assembly.
9. Remove the differential bearing caps, the bearing cap mounting bolts and the washers.
10. Lift the differential and ring gear, adjusting rings and bearing caps out of the differential carrier.
11. Mark the adjusting rings and bearing caps left or right for ease of assembly.

**Important:** the ring gear and pinion are a matched set. If the ring gear is being replaced, the pinion must also be replaced. Refer to *Pinion and Ring Gear Replacement (Spicer Dana S135 and S150 14 Inch)* in this supplement.

12. If the ring gear (1) is to be reused, remove it from the differential case (2) as follows.
  - 12.1. Carefully center punch each rivet head using a soft face or heavy duty plastic hammer.
  - 12.2. Using a 9/16 inch drill bit, carefully drill through each rivet as shown.
  - 12.3. Using a rounded punch, drive out the remaining portion of the rivets.

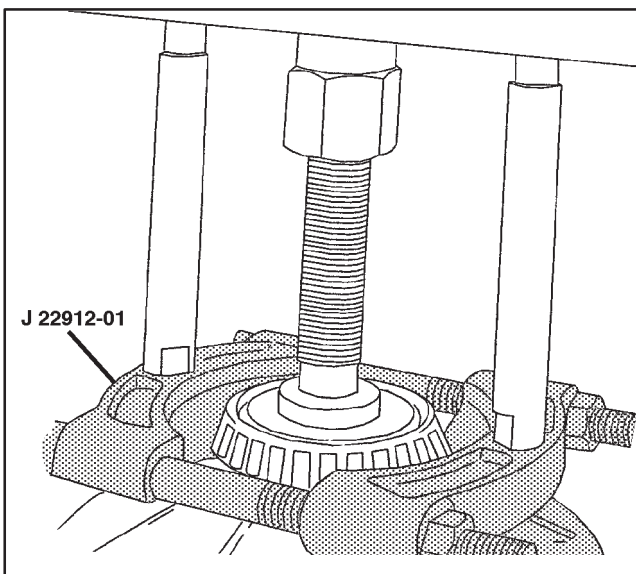

WRK42030

13. Remove the differential side bearings using the *J 22912-01*.
14. Clean and inspect all parts before assembly.

**Installation Procedure**

1. Install the differential side bearings using a suitable bearing installer.
2. Position the ring gear on the differential case with the rivet holes aligned.

**Notice:** Refer to *Fastener Notice* in Cautions and Notices in the WCC Service Manual.

3. Install new ring gear to case rivets.

**Notice:** The ring gear and differential assembly are heavy. Be careful not to damage the teeth on the ring gear and pinion when installing them into the carrier.

4. Install the ring gear and differential with bearing cups installed into the differential carrier.

**Important:** Make sure that the bearing cups are fully seated on the bearing cones before proceeding.

5. Install the bearing caps in their match marked locations.
6. Clean the bearing cap bolts and washers, then coat the bolt threads with Loctite® #277 (red) or equivalent thread locking compound.
7. Install the bearing cap bolts and tighten them enough to eliminate the visible space between the bearing cap and the differential carrier. Do not torque the bearing cap bolts at this time.
8. Install the adjusting rings in the match marked locations.

**Notice:** The differential assembly must be aligned with the bearing bores before beginning the backlash adjustment or damage to the side bearings is likely to occur.

9. Tighten both adjusting rings with a spanner wrench until the endplay is eliminated and there is backlash between the ring gear and pinion.
10. Loosen the adjusting ring on the gear tooth side of the ring gear one notch and tighten the adjusting ring on the flange tooth side of the ring gear one notch.
11. Repeat step 10 until all backlash between the pinion and the ring gear has been eliminated.

**Important:** The adjustment in step 12 sets both the backlash and the differential side bearing preload.

12. Tighten the adjusting ring on the gear tooth side of the ring gear until the pinion to ring gear backlash is equal to the specification etched on the ring gear.

**Important:** If the backlash varies more than 0.080 mm (0.003 in) in the next step remove the differential and determine the cause.

13. Measure the ring gear and pinion backlash with a dial indicator in four equally spaced positions around the ring gear as shown. The variation in backlash measurements should be within 0.051 mm (0.002) inch.

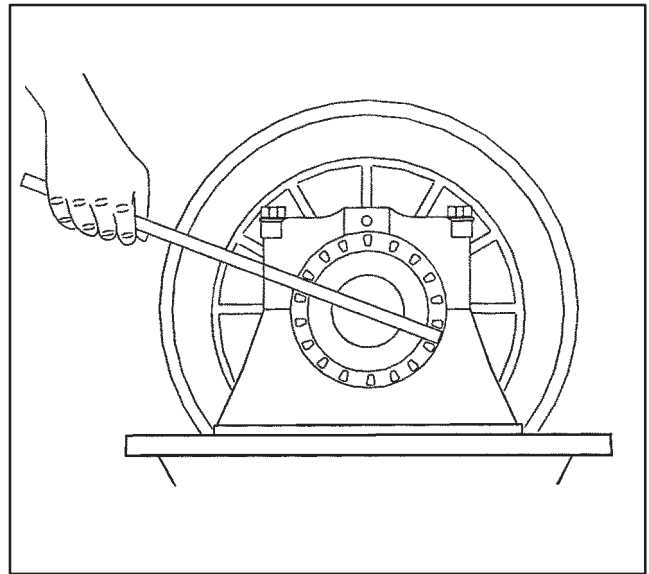

WRK42033

14. Once the backlash is correct, the bearing cap bolts can be final tightened.

**Tighten**

Tighten the bearing cap bolts to 183 N·m (135 lb ft).

15. Recheck the backlash to ensure it is correct and readjust if necessary.
16. Perform a gear tooth contact pattern check. Refer to *Gear Tooth Contact Pattern Check (Spicer Dana S135 and S150 14 Inch)* in this supplement.
17. Install the adjusting locks and lock bolts.

**Tighten**

The adjusting lock bolts to 41 N·m (30 lb ft).

18. Install the differential carrier to the rear axle housing. Refer to *Differential Carrier Replacement (Spicer Dana S135 and S150 14 Inch)* in this supplement.
19. Install the axle shafts. Refer to *Axle Shaft Replacement (Spicer Dana S135 and S150 14 Inch)* in this supplement.
20. Connect the propeller shaft. Refer to *Three Piece Propeller Shaft Replacement* in the WCC Service Manual.

**Notice:** To prevent loss of rear axle lubricant and possible damage to rear axle components, allow one hour for the form-a-gasket material used between the carrier and the rear axle housing to cure before adding rear axle lubricant.

21. Refill the rear axle. Refer to *Lubricant Change (Spicer Dana S135 and S150 14 Inch)* in this supplement.
22. Lower the vehicle.

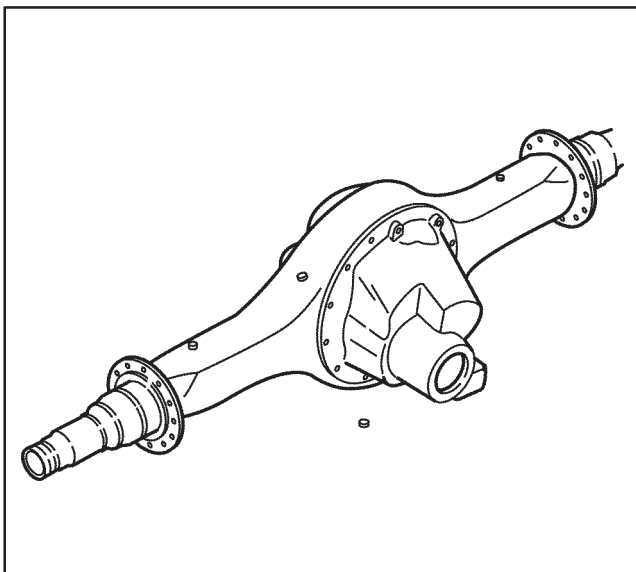

WRK42014

### Differential Carrier Replacement (Spicer Dana S135 and S150 14 Inch)

**Important:** In order to remove the maximum amount of foreign material and contaminants, always drain the rear axle lubricant when it is at its normal operating temperature.

#### Removal Procedure

1. Raise the vehicle. Refer to *Lifting and Jacking the Vehicle* in the WCC Service Manual.
2. Place a suitable container under the rear axle housing cover to catch draining lubricant.
3. Remove the rear axle drain plug and let the lubricant drain into the container.

4. Disconnect the propeller shaft. Refer to *Three Piece Propeller Shaft Replacement* in the WCC Service Manual.
5. Remove the axle shafts. Refer to *Axle Shaft Replacement (Spicer Dana S135 and S150 14 Inch)* in this supplement.
6. Support the differential carrier with a suitable floor or roller jack.
7. Secure the differential carrier to the jack to prevent it from falling when it is separated from the rear axle housing.
8. Loosen, but do not remove, the differential carrier to rear axle housing mounting bolts.

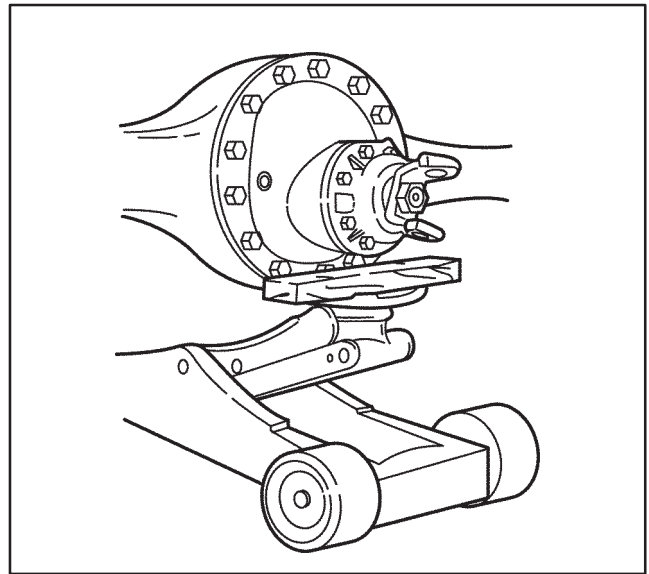

WRK42078

**Important:** When removing the carrier to housing mounting bolts, leave the top two bolts attached. This will ensure that the carrier doesn't fall off of the jack when it is separated from the rear axle housing.

9. Remove all of the differential carrier to rear axle housing mounting bolts except the top two.
10. Separate the differential carrier from rear axle housing using the two removal slots (1).
11. With the differential carrier properly balanced on the jack, remove the top two bolts. Then move the differential carrier away from the vehicle.
12. If repairs are to be made, mount the differential carrier to a suitable repair stand.

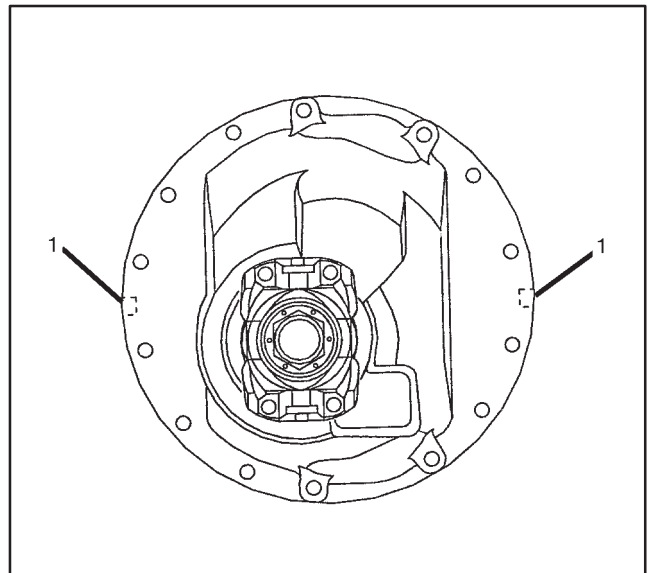

WRK42026

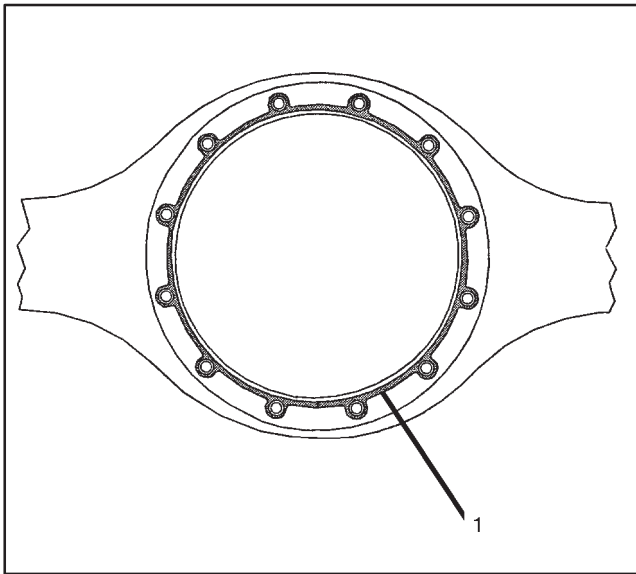

WRK42027

### Installation Procedure

1. Thoroughly clean the inside of the rear axle housing and the sealing surfaces of the differential carrier and rear axle housing.
2. Inspect the sealing surfaces for nicks, burrs and general cleanliness. Stone the surfaces, if necessary, to remove nicks and burrs.
3. Apply a 1/8-inch bead (1) of form-a-gasket, such as Loctite® 518 Gasket Eliminator, to the rear axle housing mounting flange.
4. Thread two guide studs into the axle housing 180 degrees apart.
5. Support the differential carrier with a suitable floor or roller jack.
6. Secure the differential carrier to the jack to prevent it from falling when it is joined to the rear axle housing.
7. Carefully move the differential carrier onto the guide studs until it seats against the rear axle housing mounting flange.
8. Coat the differential carrier to rear axle housing mounting bolts with Loctite® #277 (red) or equivalent thread locking compound.

**Notice:** Refer to *Fastener Notice* in Cautions and Notices in the WCC Service Manual.

9. Install the differential carrier to rear axle housing mounting bolts and remove the guide studs.

### Tighten

Tighten the differential carrier to rear axle housing mounting bolts in a cross pattern to 163 N·m (120 lb ft).

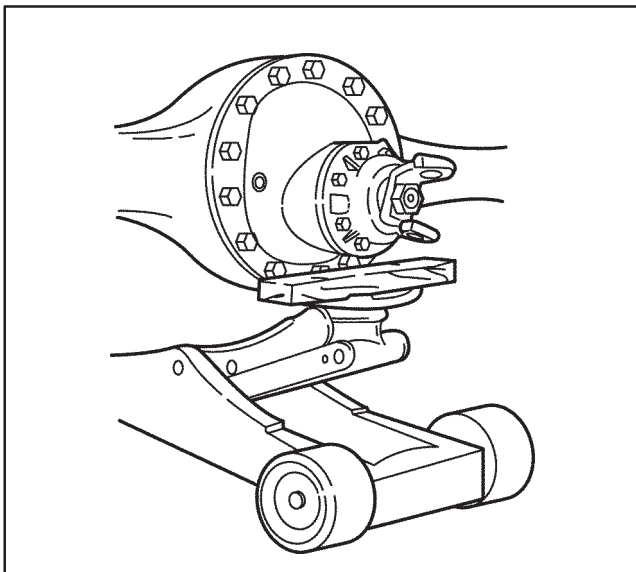

WRK42078

11. Remove the jack from the differential carrier.
12. Connect the propeller shaft. Refer to *Three Piece Propeller Shaft Replacement* in the WCC Service Manual.
13. Install the axle shafts. Refer to *Axle Shaft Replacement (Spicer Dana S135 and S150 14 Inch)* in this supplement.

**Notice:** To prevent loss of rear axle lubricant and possible damage to rear axle components, allow one hour cure time for the form-a-gasket material before adding rear axle lubricant.

14. Refill the rear axle. Refer to *Lubricant Change (Spicer Dana S135 and S150 14 Inch)* in this supplement.
15. Lower the vehicle.

## Differential Overhaul (American Axle 10 1/2 and 11 1/2 Inch)

### Tools Required

- J 8092 Driver Handle
- J 29721 Universal Bearing Puller
- J 29710 Differential Side bearing Installer (10 1/2 Inch Axle)
- J 44420 Differential Bearing and Hub Seal Installer (11 1/2 Inch Axle)

### Disassembly Procedure

1. Remove the differential side bearings using the J 29721.

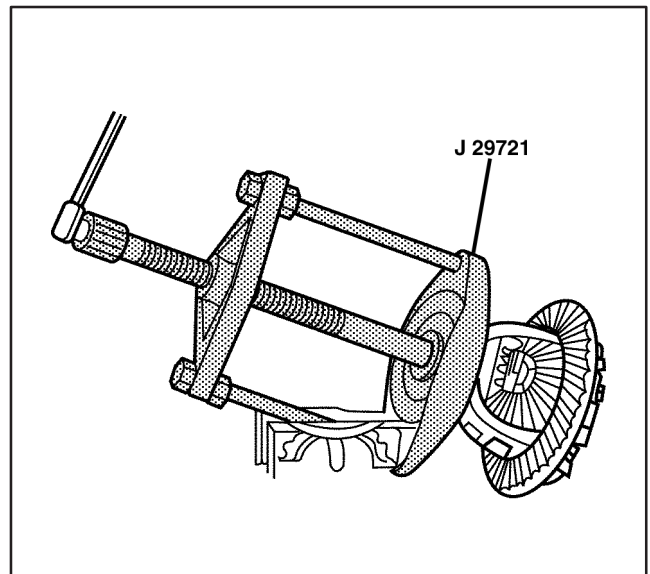

WRK42128

**Important:** The ring gear bolts have left-hand threads.

2. Remove the ring gear bolts.

**Notice:** Do not pry the ring gear from the case. This will damage the ring gear and case. Drive the ring gear off with a hammer and brass drift, if necessary.

3. Remove the ring gear from the differential case.

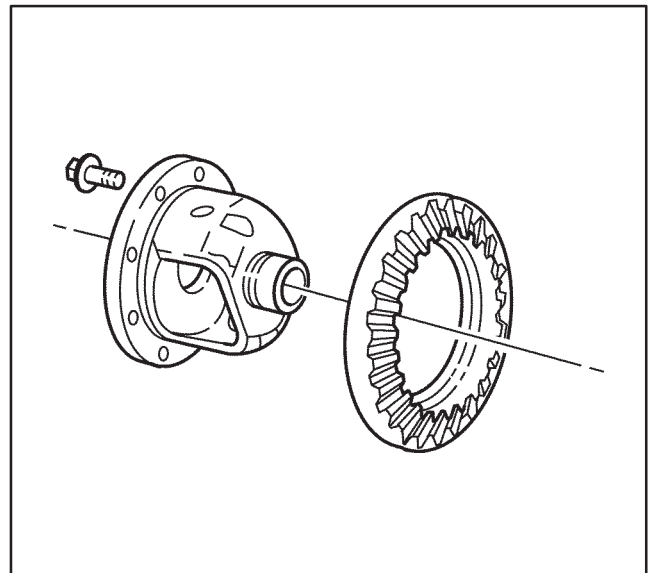

WRK42099

4. Drive out the pinion shaft roll pin.
5. Remove the pinion shaft.
6. Roll the differential pinion gears and thrust washers out of the case.
7. Mark the pinions top and bottom.
8. Remove the differential side gears and thrust washers out of the case.
9. Mark the side gears left and right.

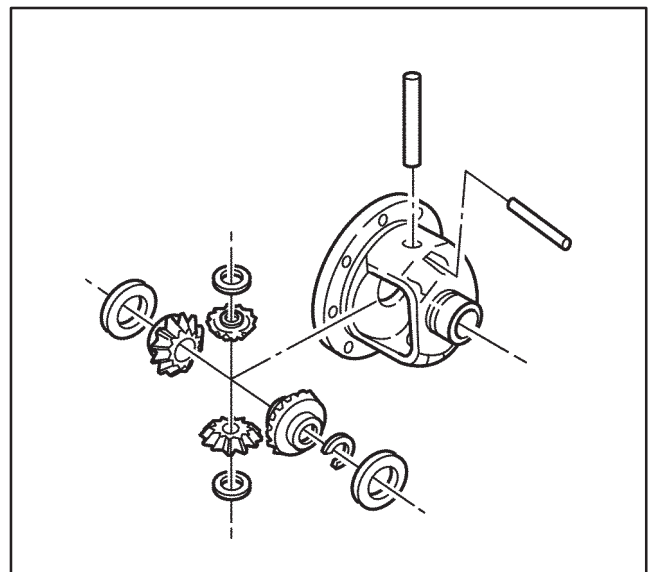

WRK42100



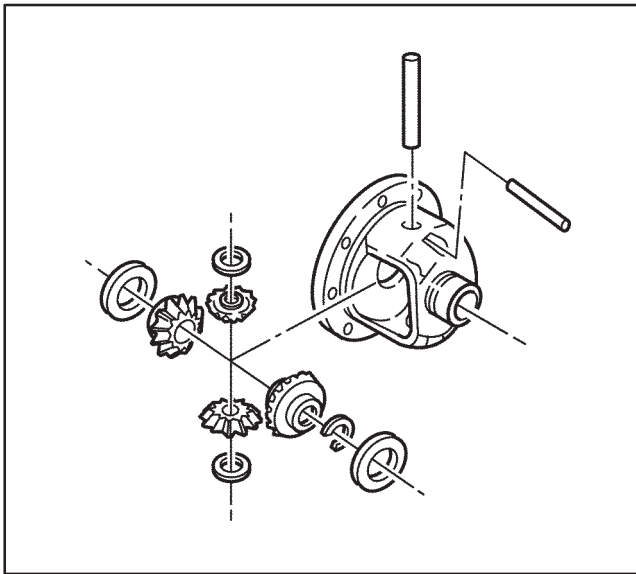

WRK42100

### Assembly Procedure

1. Lubricate the pinion and side gears with axle lubricant. Refer to *Fluid and Lubricant Recommendations* in this supplement.

**Important:** If the same side gears or pinion gears are being used, install them in their original locations.

2. Install the side gears and thrust washers into the differential case.
3. Install the pinion gears and thrust washers into the differential case by doing the following:
  - 3.1. Position one pinion gear between the differential side gears.
  - 3.2. Rotate the differential side gears until the pinion gear is directly opposite the hole in the differential case.
  - 3.3. Place the other pinion gear between the differential side gears.
  - 3.4. Line up the holes in the pinion gears, and then install the thrust washers.
  - 3.5. Rotate the pinion gears and thrust washers until the holes in the pinion gears line up with the holes in the differential case.

**Notice:** When installing the pinion shaft, take care to ensure that the hole in the pinion shaft aligns with the holes in the case.

4. Install the pinion shaft.
5. Install a new roll pin.
6. Using a ball-peen hammer, peen metal from the differential case over the roll pin to lock it into position.

**Important:** The mating surfaces of the ring gear and the differential case must be clean and free from burrs before installing the ring gear.

7. Install two threaded guide studs into the ring gear on opposite sides.
8. Aligning the studs with the holes in the differential case, lower the ring gear into position.

**Notice:** Refer to *Fastener Notice* in Cautions and Notices in the WCC Service Manual.

9. Install new ring gear bolts and remove the guide studs.

### Tighten

- Tighten the ring gear bolts to 298 N · m (220 lb ft) on 10 1/2 inch axles.
- Tighten the ring gear bolts to 237 N · m (175 lb ft) on 11 1/2 inch axles.

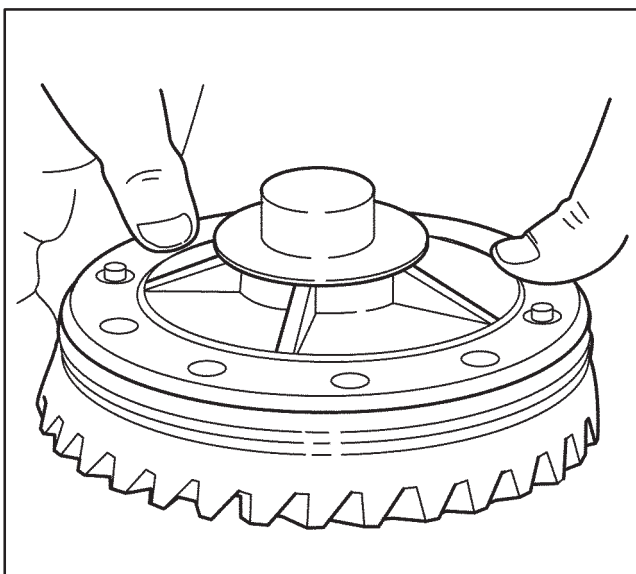

WRK42102



10. Install the differential side bearings onto the differential case by doing the following:
  - 10.1. Place one of the side bearings on the differential case.
  - 10.2. Place the *J 29710* (10 1/2 inch axle) or *J 44420* (11 1/2 inch axle) and the *J 8092* as shown in the illustration.
  - 10.3. Drive the bearing until it seats against the differential case.
  - 10.4. Install the other bearing in the same manner.

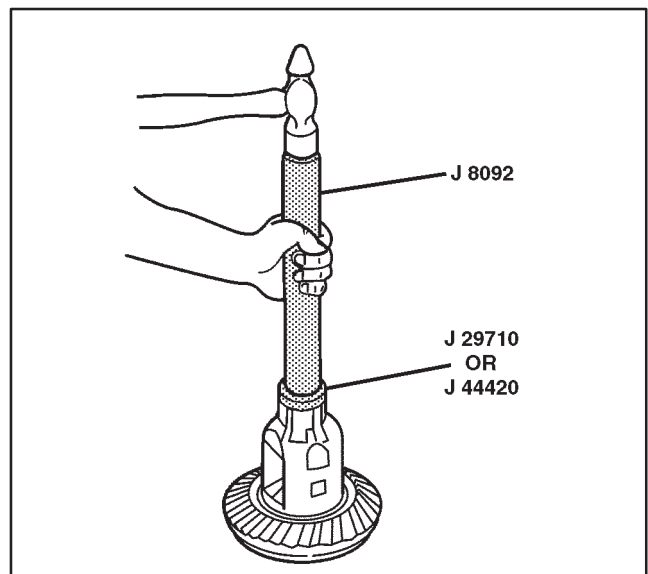

WRK42103

### Differential Overhaul (Spicer Dana S135 and S150 14 Inch)

#### Tools Required

*J 22912-01* Split Plate Bearing Puller

#### Disassembly Procedure

1. Match mark the differential halves with a punch or chisel for ease of assembly.
  2. Remove the differential case bolts.
  3. Separate the differential case halves.
  4. Remove the differential side gear and the thrust washer.
  5. Lift out the cross shaft and remove the pinion mates and thrust washers.
  6. Remove the other differential side gear and the thrust washer.
  7. Mark all components for ease of assembly.
8. If the ring gear (1) is to be reused, remove it from the differential case (2) as follows.
    - 8.1. Carefully center punch each rivet head using a soft face or heavy duty plastic hammer.
    - 8.2. Using a 9/16 inch drill bit, carefully drill through each rivet as shown.
    - 8.3. Using a rounded punch, drive out the remaining portion of the rivets.

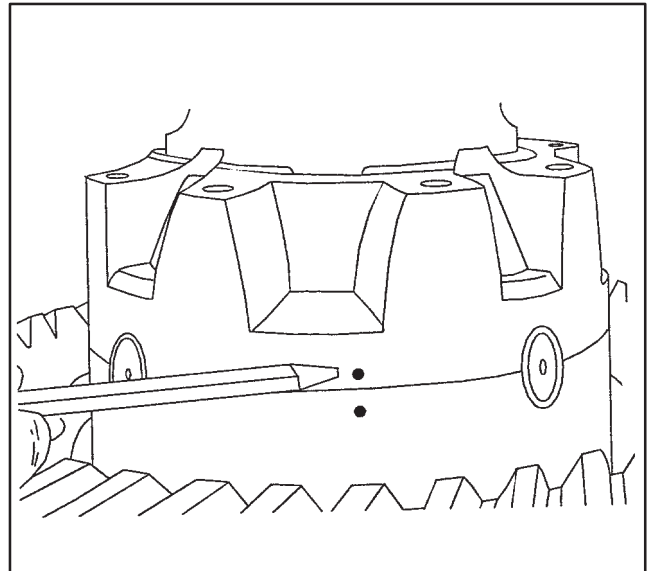

WRK42029

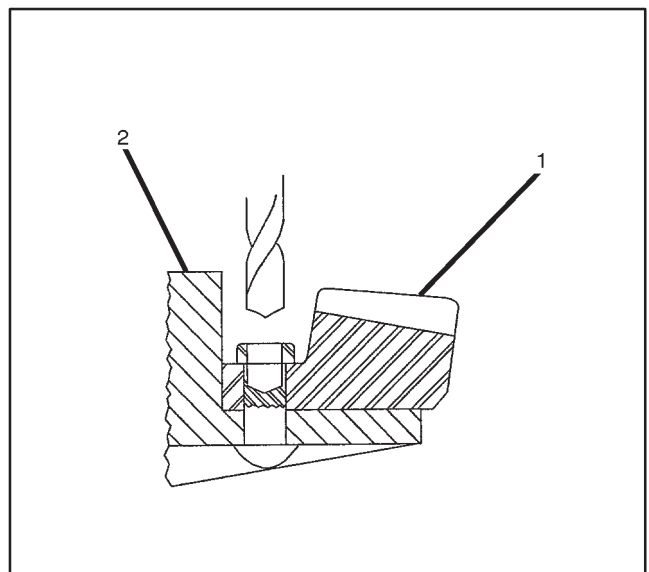

WRK42031

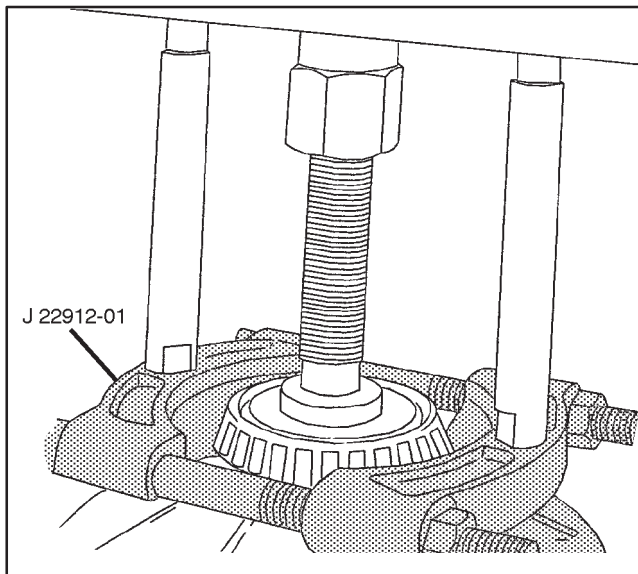

WRK42030

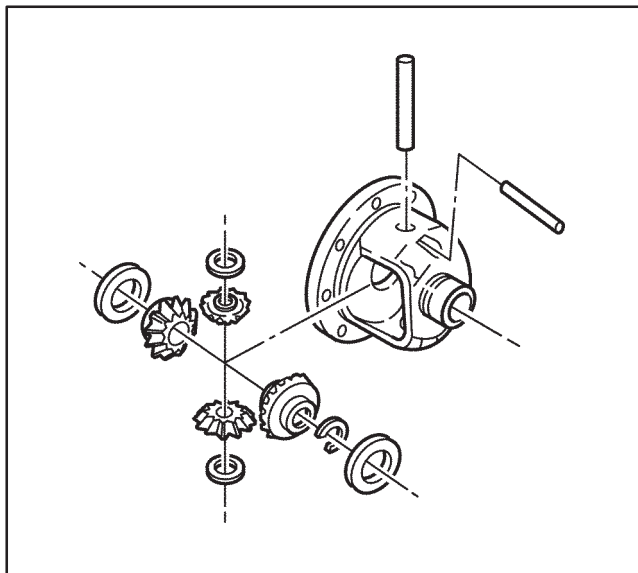

WRK42100

9. If the differential side bearings are being replaced, remove them using the *J 22912-01*.

**Important:** If any gears are to be replaced, they must be replaced in sets. Clean and inspect all parts before assembly.

10. Inspect all thrust washers for scoring and excessive wear.
11. Replace all worn or damaged parts.

### Assembly Procedure

1. If removed, install the differential side bearings using a suitable bearing installer.
2. If removed, position the ring gear on the differential case with the rivet holes aligned.

**Notice:** Refer to *Fastener Notice* in Cautions and Notices in the WCC Service Manual.

3. Install new ring gear to case rivets.
4. Lubricate the pinion and side gears with axle lubricant. Refer to *Fluid and Lubricant Recommendations* in this supplement.

**Important:** If the same side gears or pinion mates are being used, install them in their original locations.

5. Install the side gear and thrust washer into the differential case half (flange side of ring gear).
6. Install the pinion mates and thrust washers onto the cross shaft.
7. Position the cross shaft into the differential case half (flange side of ring gear).
8. Install the second side gear into the other case half (gear teeth side of ring gear).

9. Lining up the match marks made during disassembly. Place the two differential case halves together.
10. Clean the differential case bolts, then coat the bolt threads with Loctite® #277 (red) or equivalent thread locking compound.
11. Install the differential case bolts.

**Tighten**

Tighten the differential case bolts to 163 N·m (120 lb ft).

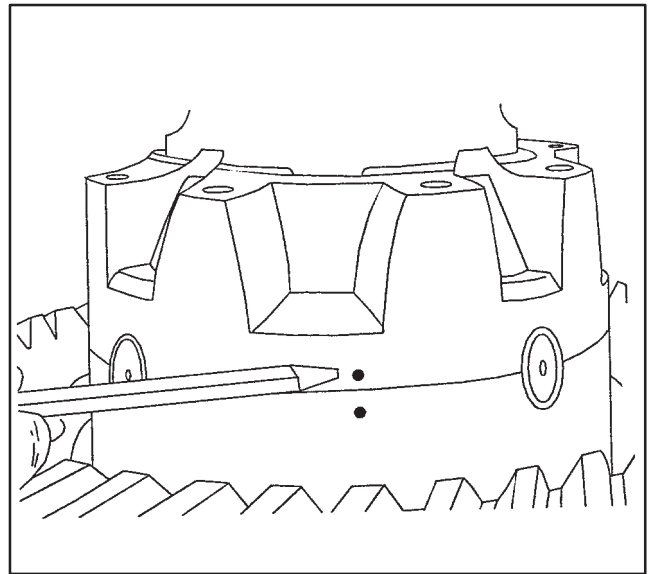

WRK42029

### Differential Side Bearing Preload Adjustment (American Axle 10 1/2 and 11 1/2 Inch)

**Tools Required**

J 24429 Side Bearing Nut Wrench

**Important:**

- The differential side bearing preload is adjusted using the two adjusting nuts installed in the differential bearing bores inside the rear axle housing. The bearing bores and the differential bearing caps provide the mating threads for the adjusting nuts.
- The differential side bearings must be preloaded in order to determine the backlash between the ring gear and the pinion gear teeth. After the backlash has been correctly set, the final differential side bearing preload is adjusted.

**Important:** The rotating torque of the drive pinion must be within specifications before the pinion gear retainer can be installed.

1. Depending on which rear axle is being adjusted, perform one of the following:
  - 1.1. On American Axle 10 1/2 Inch axles install the pinion gear retainer. Refer to *Pinion and Ring Gear Replacement (American Axle 10 1/2 Inch)* in this supplement.
  - 1.2. On American Axle 11 1/2 Inch axles install the drive pinion. Refer to *Pinion and Ring Gear Replacement (American Axle 11 1/2 Inch)* in this supplement.
2. Install the differential side bearings, if necessary. Refer to *Differential Overhaul (American Axle 10 1/2 and 11 1/2 Inch)* in this supplement.
3. Install the differential side bearing adjuster nuts into the rear axle housing differential carrier.
4. Install the selective shim packs. Refer to *Determining Total Shim Pack Size* in the WCC Service Manual.

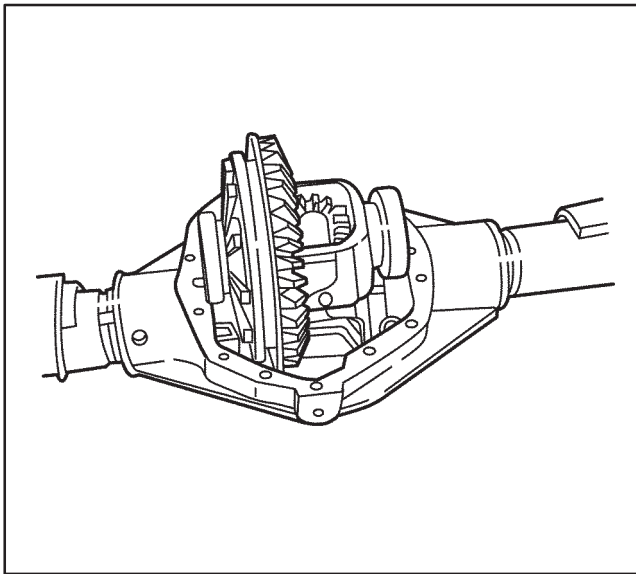

WRK42089

**Important:** Before installation of the differential case, ensure that the side bearing surfaces in the differential carrier are clean and free of burrs. If the original bearings are to be reused, the original bearing cups must also be reused.

5. Place the differential case, with bearing cups installed, into the differential carrier.

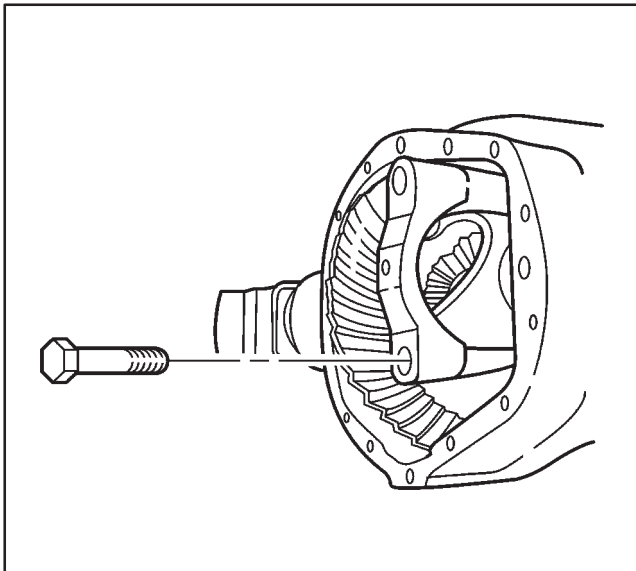

WRK42088

**Important:** If you cannot install the differential case, screw the differential side bearing adjusters into the rear axle housing until the differential case can be installed.

6. Install the differential bearing caps.

**Notice:** Refer to *Fastener Notice* in Cautions and Notices in the WCC Service Manual.

**Important:** Do not torque the bearing cap mounting bolts at this time.

7. Install the differential bearing cap mounting bolts finger tight.

**Important:** Do not force the ring gear into contact with the pinion.

8. Slide the differential case to the right until the ring gear meshes with the drive pinion. This is the zero backlash point.

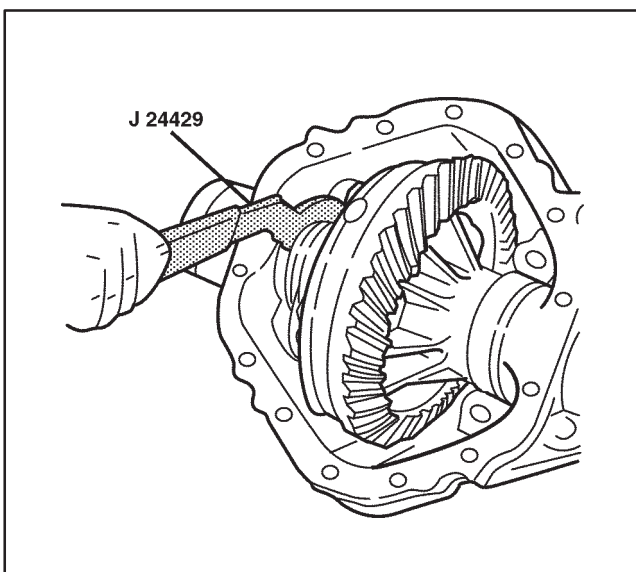

WRK42091

9. If the zero backlash cannot be obtained, turn the right differential side bearing adjuster nut in towards the axle housing using the *J 24429* until the ring gear fully contacts the pinion in order to obtain zero backlash.
10. While holding the ring gear against the pinion, turn the left differential side bearing adjuster out using the *J 24429* until it contacts the differential side bearing cup.
11. Turn the right differential side bearing adjuster nut clockwise, using the *J 24429*, until it contacts the differential side bearing cup.
12. Back off the left differential side bearing adjuster nut approximately two slots using the *J 24429* in order to obtain the initial backlash adjustment.

**Important:** Do not torque the lock bolt at this time.

13. Install the left differential side bearing adjuster nut lock and lock bolt.
14. Firmly tighten the right differential side bearing adjuster nut, using the *J 24429*, until the differential case has a solid contact with the left differential side bearing adjuster nut.
15. Rotate the pinion several times in order to seat the bearings.
16. Loosen the right differential side bearing adjuster nut, using the *J 24429*, until it is free from the differential side bearing cup.
17. Tighten the right differential side bearing adjuster nut, using the *J 24429*, until it contacts the differential side bearing cup.

#### **Tighten**

Tighten the right differential side bearing adjuster nut the following amounts:

- For used bearings, tighten the adjuster nut an additional two slots.
- For new bearings, tighten the adjuster nut an additional three slots.

**Important:** Do not torque the lock bolt at this time.

18. Install the right differential side bearing adjuster nut lock and lock bolt.

#### **Tighten**

Tighten the bearing cap bolts to the following specifications:

- For the 10 1/2 inch axles, tighten the bearing cap bolts to 185 N·m (136 lb ft).
- For the 11 1/2 inch axles, tighten the bearing cap bolts to 207 N·m (153 lb ft).

#### **Tighten**

Tighten the differential side bearing adjuster nut lock bolts to 27 N·m (20 lb ft).

19. Measure the ring gear to pinion backlash and adjust, if necessary. Refer to *Backlash Adjustment (American Axle 10 1/2 and 11 1/2 Inch)*.

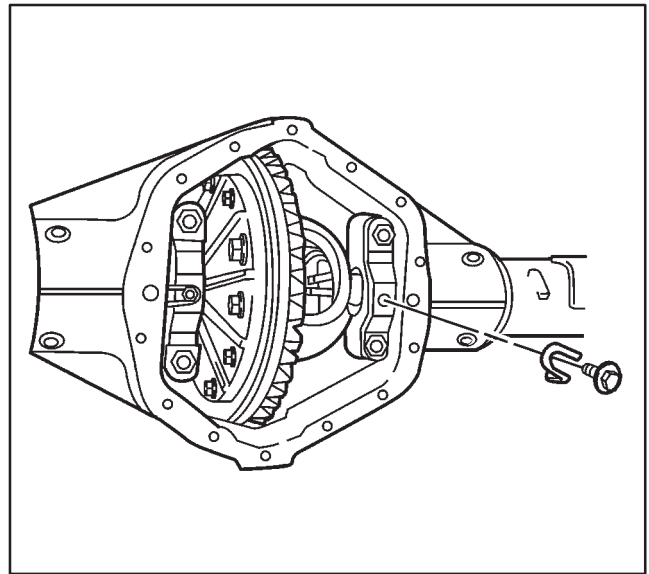

WRK42087

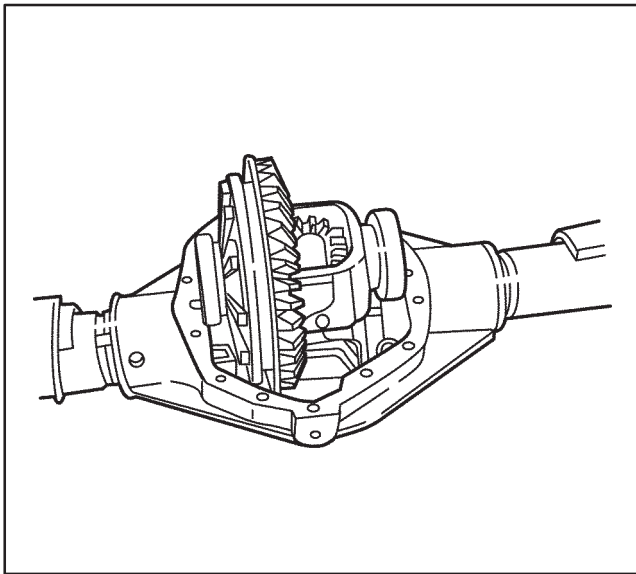

WRK42089

### Backlash Adjustment (American Axle 10 1/2 and 11 1/2 Inch)

#### Tools Required

- J 8001 Dial Indicator Set
- J 23409 Dial Indicator Extension
- J 25588 Side Bearing Shim Installer

1. Place the differential case, with bearing cups installed, into the differential carrier and determine the differential side bearing preload. Refer to *Differential Side Bearing Preload Adjustment (American Axle 10 1/2 and 11 1/2 Inch)* in this supplement.

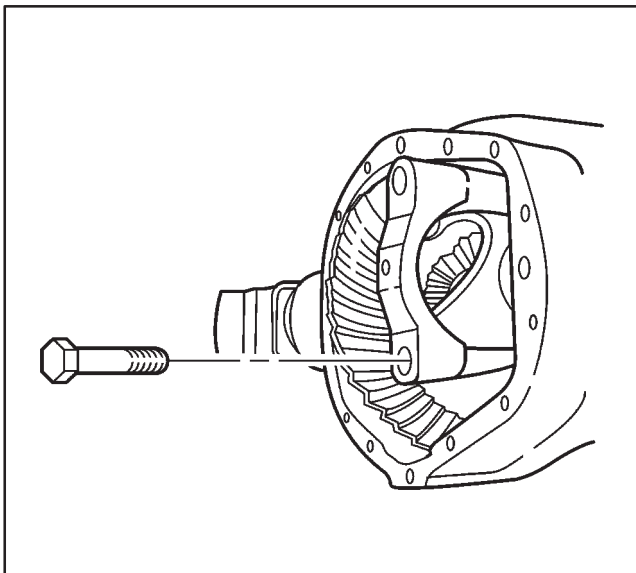

WRK42088

2. Install the differential bearing caps, if removed.

**Notice:** Refer to *Fastener Notice* in Cautions and Notices in the WCC Service Manual.

3. Install the differential bearing cap mounting bolts.

#### Tighten

Tighten the bearing cap bolts to 75 N·m (55 lb ft).

4. Rotate the differential case several times to seat the bearings.

5. Install the *J 8001* and the *J 23409* to the axle housing as shown.
6. Position the indicator stem of the *J 8001* on the heel end of a ring gear tooth.
7. Set the *J 8001* so that the stem is aligned with the gear rotation and perpendicular to the tooth angle.
8. Rotate the housing on the *J 8001* until the needle on the dial face aligns with the zero mark.
9. While holding the pinion stationary, move the ring rear back and forth while observing the dial indicator reading.
10. Record the reading.
11. Repeat steps 8 through 10 at seven more points around the ring gear. The difference between all of the measuring points should not vary by more than 0.05 mm (0.002 in).
12. If the difference between all of the measuring points is more than 0.05 mm (0.002 in), inspect for the following conditions:
  - Burrs on the ring gear or pinion gear teeth
  - A distorted case flange or ring gear
  - Uneven ring gear bolt torque
13. If the difference between all measuring points is within specifications, check that the backlash at all measuring points is between 0.13 mm (0.005 in) and 0.18 mm (0.007 in).

**Important:**

- Do not use the original equipment cast iron shims to adjust the backlash. Use the service shims and spacers instead.
  - Adjust the thickness of the shim pack on each side of the differential in equal amounts. In other words, whatever thickness you subtract from one side, you must add to the other side. This will maintain the correct differential side bearing preload.
  - Moving 0.05 mm (0.002 in) of shim thickness from one side of the differential to the other will change the backlash by 0.03 mm (0.001).
14. If the gear set has too little backlash, increase the backlash as follows:
    - 14.1. Remove the appropriate amount of thickness from the left shim pack. For example to increase the backlash 0.10 mm (0.004 in) remove 0.20 mm (0.008 in) of thickness from the left side shim pack.
    - 14.2. In order to maintain the side bearing preload, add 0.20 mm (0.008 in) of thickness to the right side shim pack.
    - 14.3. Recheck the backlash and adjust as necessary.

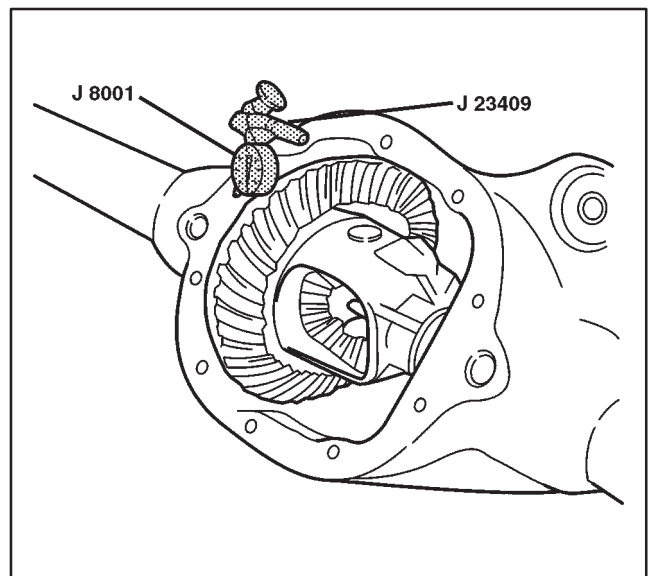

WRK42097



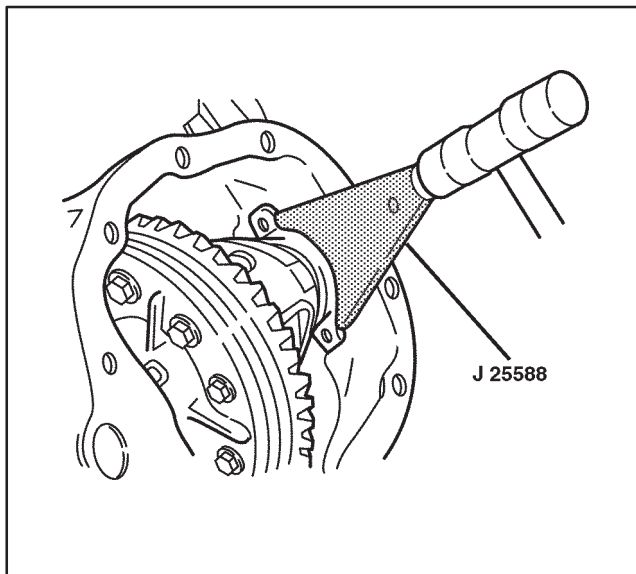

WRK42098

15. If the gear set has too much backlash, decrease the backlash as follows:
  - 15.1. Remove the appropriate amount of thickness from the right shim pack. For example to decrease the backlash 0.10 mm (0.004 in) remove 0.20 mm (0.008 in) of thickness from the right side shim pack.
  - 15.2. In order to maintain the side bearing preload, add 0.20 mm (0.008 in) of thickness to the left side shim pack.
  - 15.3. Recheck the backlash and adjust as necessary.
16. When you have correctly adjusted the backlash, remove the bearing caps and the shim packs. Do not remove the spacers.
17. Select a shim 0.10 mm (0.004 in) thicker than you removed from the left side.
18. Insert this shim between the spacer and the left differential side bearing race.
19. Install the left differential bearing cap and mounting bolts. Do not tighten the mounting bolts at this time.
20. Select a shim 0.10 mm (0.004 in) thicker than you removed from the right side.
21. Insert this shim between the spacer and the right differential side bearing race.
22. Drive the shim into position using the *J 25588* as shown.
23. Install the left differential bearing cap and mounting bolts.
 

**Tighten**  
Tighten the bearing cap bolts to 75 N·m (55 lb ft).
24. Recheck the backlash and adjust as necessary.
25. Once the backlash is correct, perform a gear tooth contact pattern check in order to ensure proper alignment between the ring gear and pinion. Refer to *Gear Tooth Contact Pattern Check (American Axle 10 1/2 and 11 1/2 Inch)* in this supplement.



## Backlash Adjustment (Spicer Dana S135 and S150 14 Inch)

1. With the differential carrier installed in a suitable fixture, remove the adjusting ring lock bolts and the adjusting ring locks.
2. Remove the differential side bearing cap bolts.

**Notice:** Refer to *Fastener Notice* in Cautions and Notices in the WCC Service Manual.

3. Install the bearing cap bolts and tighten them enough to eliminate the visible space between the bearing cap and the differential carrier. Do not torque the bearing cap bolts at this time.
4. Install the adjusting rings in the match marked locations.

**Notice:** The differential assembly must be aligned with the bearing bores before beginning the backlash adjustment or damage to the side bearings is likely to occur.

5. Tighten both adjusting rings with a spanner wrench until the endplay is eliminated and there is backlash between the ring gear and pinion.
6. Loosen the adjusting ring on the gear tooth side of the ring gear one notch and tighten the adjusting ring on the flange tooth side of the ring gear one notch.
7. Repeat step 6 until all backlash between the pinion and the ring gear has been eliminated.

**Important:** The adjustment in step 8 sets both the backlash and the differential side bearing preload.

8. Tighten the adjusting ring on the gear tooth side of the ring gear until the pinion to ring gear backlash is equal to the specification etched on the ring gear.

**Important:** If the backlash varies more than 0.080 mm (0.003 in) in the next step remove the differential and determine the cause.

9. Measure the ring gear and pinion backlash with a dial indicator in four equally spaced positions around the ring gear as shown. The variation in backlash measurements should be within 0.051 mm (0.002) inch.
10. Once the backlash is correct, the bearing cap bolts can be final tightened.

### Tighten

Tighten the bearing cap bolts to 183 N·m (135 lb ft).

11. Recheck the backlash to ensure it is correct and readjust if necessary.
12. Perform a gear tooth contact pattern check. Refer to *Gear Tooth Contact Pattern Check (Spicer Dana S135 and S150 14 Inch)* in this supplement.
13. Install the adjusting locks and lock bolts.

### Tighten

The adjusting lock bolts to 41 N·m (30 lb ft).

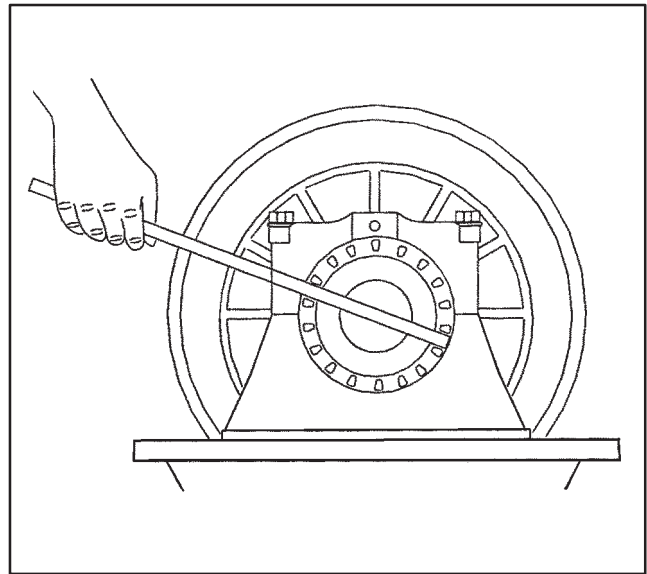

WRK42033

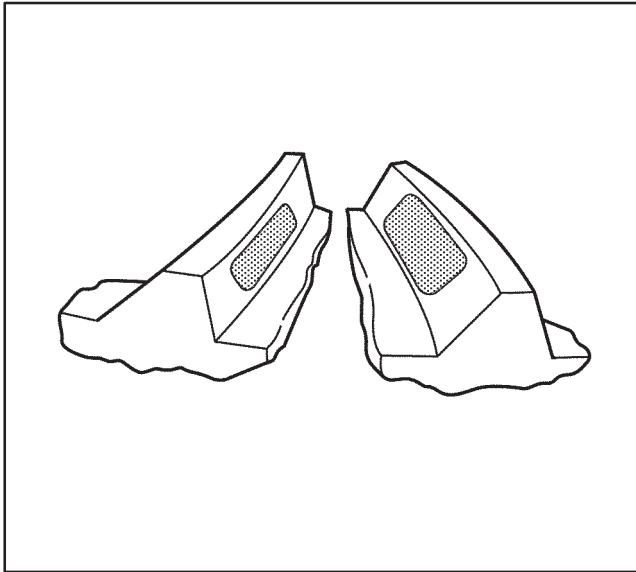

WRK42117

### **Gear Tooth Contact Pattern Check (American Axle 10 1/2 and 11 1/2 Inch)**

**Important:** The gear tooth contact pattern check is not a substitute for adjusting pinion depth and backlash. Use this method in order to verify the correct position of the ring gear and pinion. Gear sets, which are not positioned properly, may be noisy and have a short life span. A pattern check ensures that the best contact has been obtained between the ring gear and the pinion. This will ensure the system will produce low noise and have a long life.

### **Drive Pinion and Ring Gear Identification**

Production drive pinions and ring gears are manufactured using a 2-cut or a 5-cut method. The 2-cut pinions and ring gears can be identified by a groove cut into the outside edge of the ring gear and a ring on the stem of the pinion.

The gear tooth contact patterns that are produced by each type of gear set differ slightly. A 2-cut gear set will produce a diagonal pattern from the toe to the heel on the drive side of each tooth, while a 5-cut style gear set will produce a square pattern from the toe to the heel on the drive side of each tooth.

When diagnosing a gear contact pattern, regardless of which style of gear set is being used, it must be centered within the area of the tooth, from toe to heel and from top to bottom as shown in the illustration.

### Gear Tooth Nomenclature

The side of the ring gear tooth that curves outward, or is convex, is called the drive side of the tooth (4). The side of the ring gear tooth that curves inward, or is concave, is called the coast side of the tooth (3). The end of the tooth nearest the center of the ring gear is called the toe end of the tooth (2) and the end that is farthest away from the center of the ring gear is called the heel end of the tooth (1).

### Adjustments Affecting Tooth Contact

Both the backlash adjustment and the pinion depth adjustment affect tooth contact. While the affects of bearing preload adjustments are not readily apparent on hand-loaded tooth contact pattern tests, bearing preloads should be within specifications before making backlash and pinion depth adjustments.

### Backlash Adjustment

The backlash adjustment is made by varying the thickness of the differential side bearing shims from side to side. This adjustment will move the ring gear closer to or further away from the pinion. In most cases, adjusting the backlash will correct an abnormal gear tooth contact pattern and will also properly set the differential side bearing preload.

When adjusting backlash remember the following:

- Moving shims from the left side of the differential to the right side increases backlash.
- Moving shims from the right side of the differential to the left side decreases backlash.
- Adjust the thickness of the shim pack on each side of the differential in equal amounts. In other words, whatever thickness you subtract from one side, you must add to the other side. This will maintain the correct differential side bearing preload.

### Pinion Depth Adjustment

The pinion depth adjustment increases or decreases the distance between the pinion head and centerline of the ring gear. This distance is adjusted by adding a thicker or thinner selective shim between the pinion inner bearing and the pinion rear face. Installing a thicker shim moves the pinion moves closer to the centerline of the ring gear. Using a thinner shim moves the pinion further away from the centerline of the ring gear.

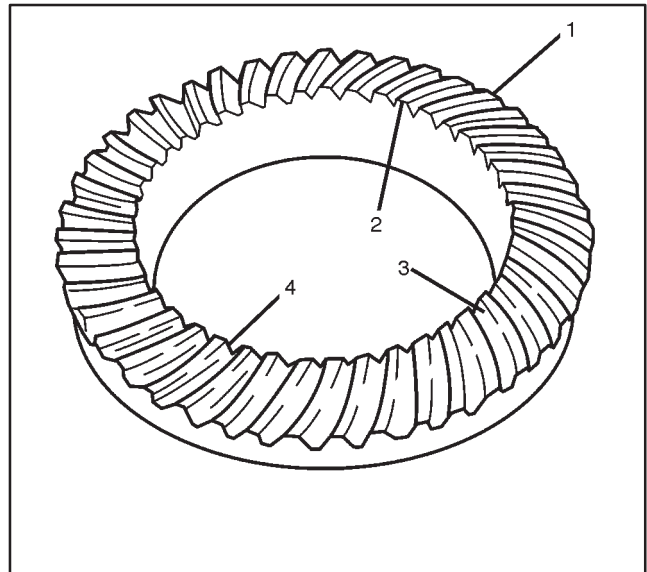

WRK42105

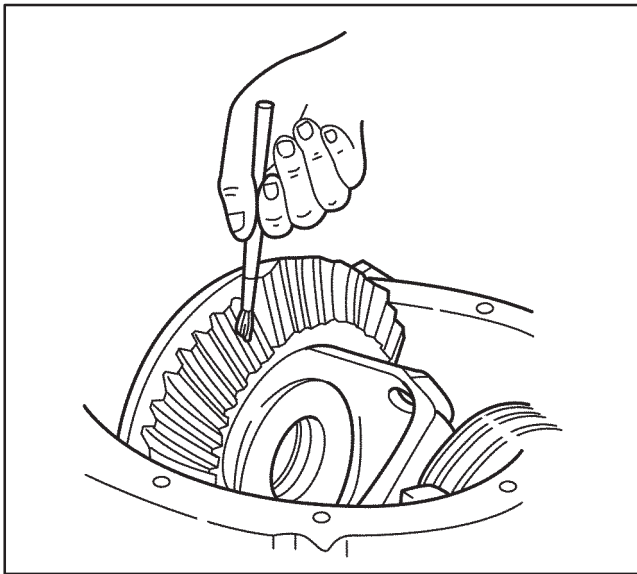

WRK42116

### Gear Tooth Contact Pattern Check Procedure

1. Wipe the differential case, the ring gear, the pinion, and the rear axle housing until they are free of lubricant. Carefully clean the lubricant off of each gear tooth.
2. Using a medium stiff brush apply gear marking compound, GM P/N 1052351 or equivalent, sparingly to all of the ring gear teeth.

#### Tighten

Tighten the differential side bearing cap bolts to the following specifications:

- For the 10 1/2 inch axles, tighten the bearing cap bolts to 185 N·m (136 lb ft).
- For the 11 1/2 inch axles, tighten the bearing cap bolts to 207 N·m (153 lb ft).

**Important:** Performing a gear tooth contact pattern test without loading the gears will not produce a satisfactory result.

3. Have an assistant apply the service brakes until a torque load of 14 N·m (10 lb ft) is required to turn the pinion.

**Important:** Avoid excessive turning of the ring gear.

4. Using a wrench, rotate the pinion flange until the ring gear has turned three full revolutions.
5. Turn the drive pinion flange in the opposite direction until the ring gear has turned three full revolutions.
6. Observe the pattern on the ring gear teeth and compare it to the following illustrations.

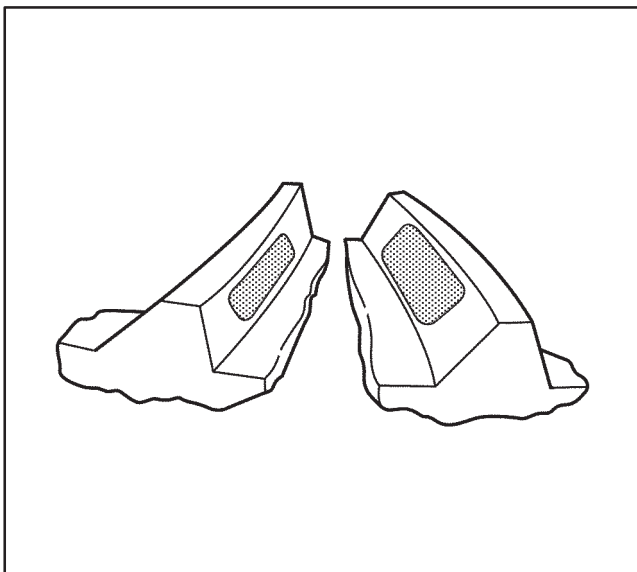

WRK42117

### Correct Contact Pattern

#### Condition

- The backlash is correct.
- The pinion depth is correct.

#### Correction

Correction should not be necessary.

**Drive Side Heel Contact; Coast Side Toe Contact****Condition**

- The backlash is incorrect.
- The ring gear is too far away from the pinion.

**Correction**

Move shims from the right side of the differential to the left side to decrease backlash. Refer to *Backlash Adjustment (American Axle 10 1/2 and 11 1/2 Inch)* in this supplement.

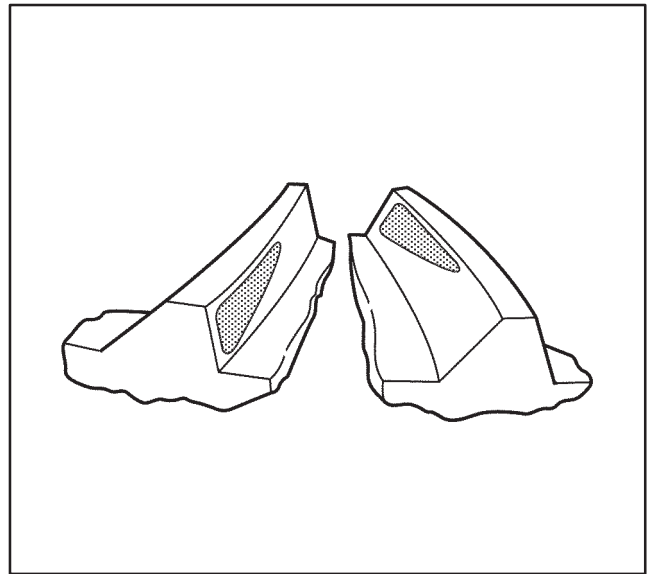

WRK42119

**Drive Side Toe Contact; Coast Side Heel Contact****Condition**

- The backlash is incorrect.
- The ring gear is too close to the pinion.

**Correction**

Move shims from the left side of the differential to the right side to increase backlash. Refer to *Backlash Adjustment (American Axle 10 1/2 and 11 1/2 Inch)* in this supplement.

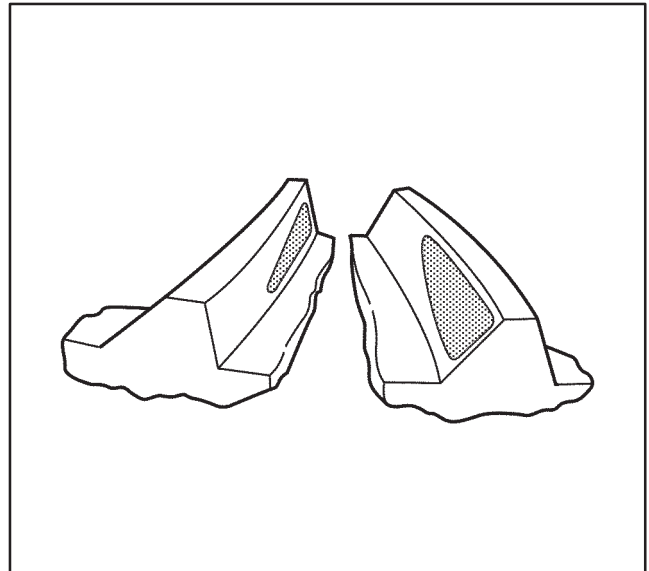

WRK42120

**Drive Side Toe Contact; Coast Side Toe Contact****Condition**

- The backlash is incorrect.
- The ring gear is too far away from the pinion.

**Correction**

Move shims from the right side of the differential to the left side to decrease backlash. Refer to *Backlash Adjustment (American Axle 10 1/2 and 11 1/2 Inch)* in this supplement.

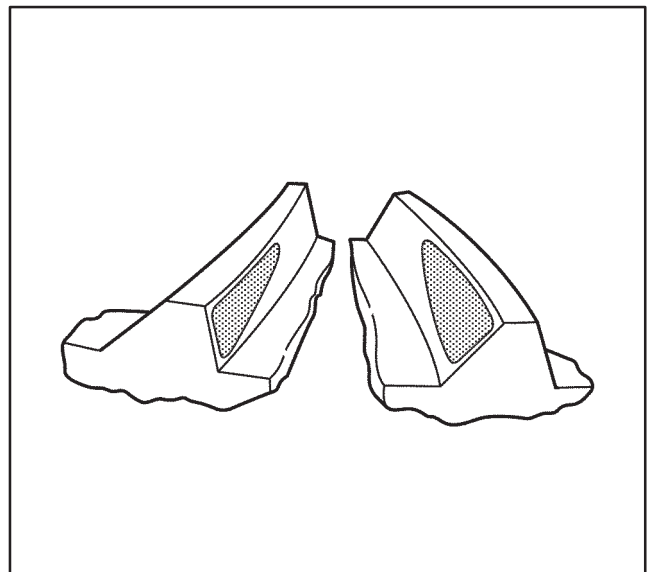

WRK42121

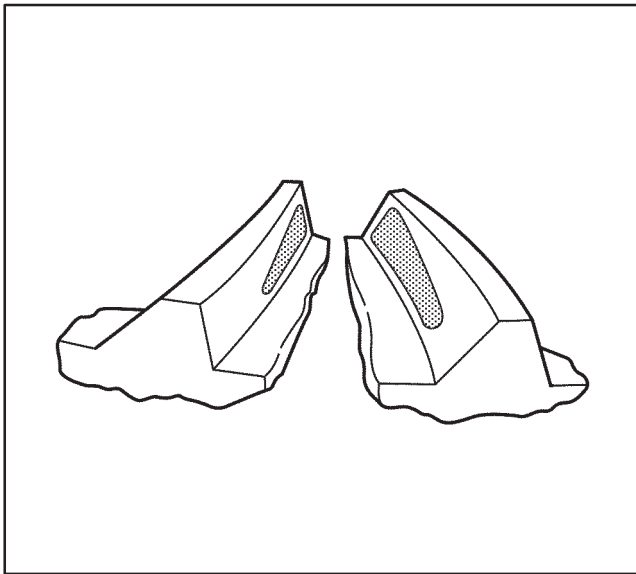

WRK42122

### Drive Side Heel Contact; Coast Side Heel Contact

#### Condition

- The backlash is incorrect.
- The ring gear is too close to the pinion.

#### Correction

Move shims from the left side of the differential to the right side to increase backlash. Refer to *Backlash Adjustment (American Axle 10 1/2 and 11 1/2 Inch)* in this supplement.

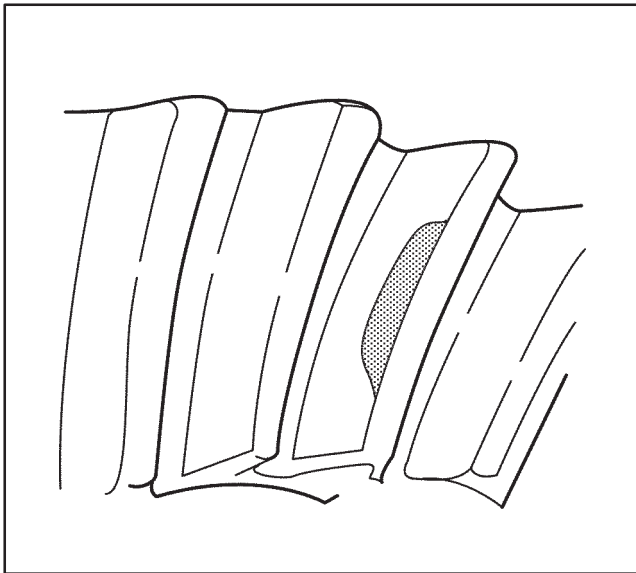

WRK42125

### High Flank Contact Pattern

#### Condition

- The pinion depth is incorrect.
- The pinion is too far away from the ring gear centerline.

#### Correction

Increase the pinion depth by increasing the selective shim thickness. Refer to *Pinion Depth Adjustment* in the WCC Service Manual for 10 1/2 inch axles or *Pinion Depth Adjustment (American Axle 11 1/2)* in this supplement.

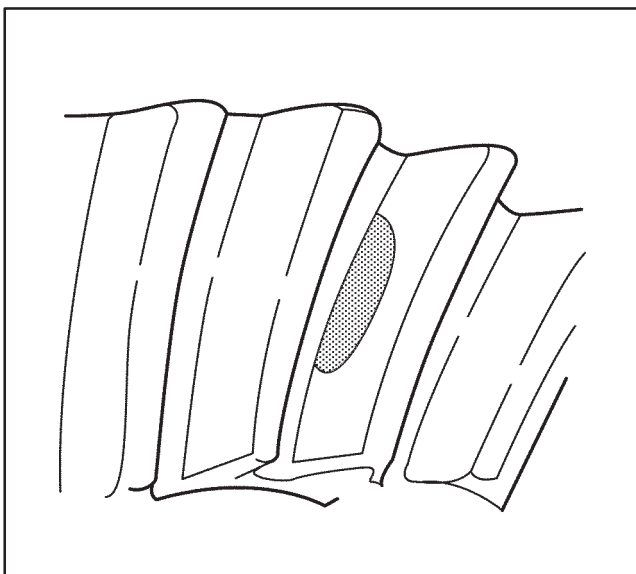

WRK42126

### Low Flank Contact Pattern

#### Condition

- The pinion depth is incorrect.
- The pinion is too close to the ring gear centerline.

#### Correction

Decrease the pinion depth by decreasing the selective shim thickness. Refer to *Pinion Depth Adjustment* in the WCC Service Manual for 10 1/2 inch axles or *Pinion Depth Adjustment (American Axle 11 1/2)* in this supplement.

## Rear Hub and Bearing Replacement (Spicer Dana S135 and S150 14 Inch)

### Tools Required

- J 8092 Driver Handle
- J 41107 Oil Seal Installation Kit

### Removal Procedure

1. Raise and suitably support the vehicle with jack stands. Refer to *Lifting and Jacking the Vehicle* in the WCC Service Manual.
2. Release the parking brake.
3. Remove the tire and wheel assemblies. Refer to *Tire and Wheel Removal and Installation* in the WCC Service Manual.
4. Remove the axle shafts. Refer to *Axle Shaft Replacement (Spicer Dana S135 and S150 14 Inch)* in this supplement.
5. Remove the brake calipers. Refer to *Brake Caliper Replacement (Rear)* in the WCC Service Manual.
6. Remove the outer nut, the nut lock, and the inner nut.
7. Remove the rear hub and rotor assembly from the axle housing.
8. Remove the outer rear wheel bearing cone.
9. Remove the rear wheel bearing seal.
10. Remove the inner rear wheel bearing cone.

**Important:** When installing a new bearing cone the mating cup should always be changed.

11. If the bearing cones are being replaced, drive out the bearing cups using a brass drift.

**Caution:** *Never dry bearings by spinning them with compressed air. The bearings could come apart causing serious injury and may be damaged by a lack of lubrication.*

12. Clean the rear wheel bearing cones in clean mineral spirits.

**Caution:** *When cleaning brake parts, do not create dust using a dry brush or compressed air. Aftermarket brake parts may contain asbestos fibers which may cause serious bodily harm. Clean brake parts with a water dampened cloth, a water based solution, or commercial equipment designed for that purpose to prevent these fibers from becoming airborne.*

13. Clean the rear hub and rotor assembly and the axle housing spindle with brake parts cleaner GM P/N 12345754, or equivalent.
14. Inspect the rear wheel hub, replace if damaged.
15. Inspect the rear wheel studs and axle flange studs for looseness, damaged threads and bends.
16. Inspect the rear wheel bearing cones for excessive wear, chipped edges, and flat spots.
17. Inspect the rear wheel bearing cups for cracks and pits.
18. Inspect the rear axle spindle for stripped threads and other damage.
19. Inspect the rear brake rotor for scoring.

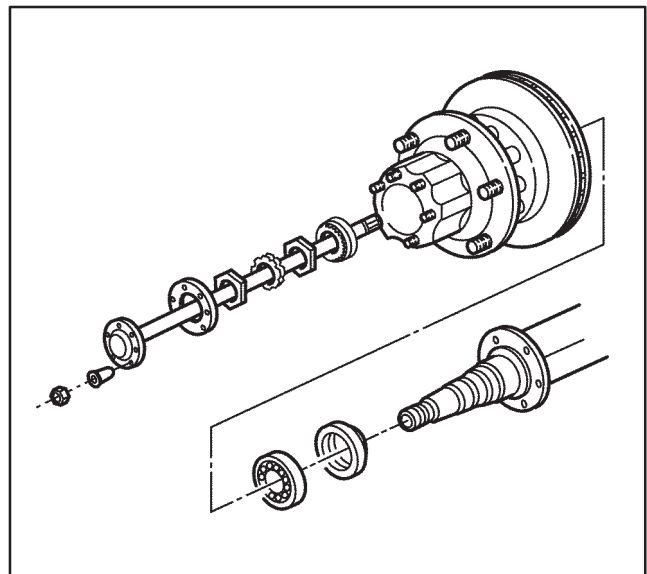

WRK42076



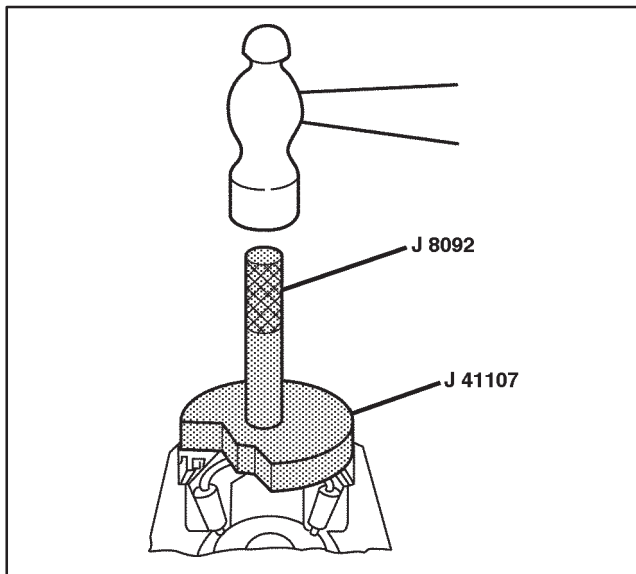

WRK42077

### Installation Procedure

1. Lubricate the wheel bearings, the rear axle housing tubes, the inside of the wheel hub, the rear wheel seal, the rear axle housing spindle sealing surface. Refer to *Lubrication Specifications* in this supplement.

**Important:** The bearing cups must seat squarely against the hub shoulder in order to be able to properly adjust the wheel bearings.

2. If removed, install the bearing cups using a brass drift and a hammer to alternately drive against the outer edges to seat the cups squarely in the hub bore.
3. Install the inner rear wheel bearing cone.

**Notice:** Do not continue to hammer after the rear wheel seal has bottomed evenly all around, as this will cause damage to the seal.

4. Install the rear wheel seal as follows:
  - 4.1. Apply silicone sealer (RTV), or equivalent, to the outside diameter of the seal.
  - 4.2. Place the seal on the hub with the seal lip facing inward.
  - 4.3. Install the seal using the *J 41107* and the *J 8092* by striking a sharp blow with the hammer, then tapping the seal until it seats evenly in the hub bore.

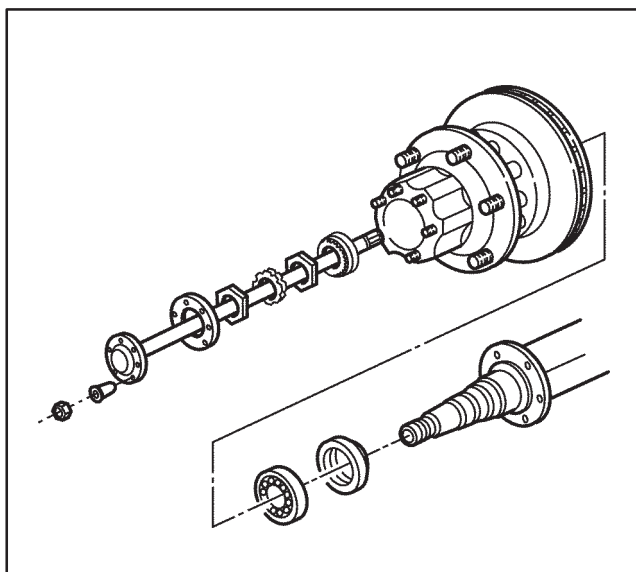

WRK42076

5. Install the hub and rotor assembly.
6. Install the outer rear wheel bearing cone.
7. Install the rear bearing inner nut, the nut lock, and the outer nut.
8. Install the brake calipers. Refer to *Brake Caliper Replacement (Rear)* in the WCC Service Manual.
9. Install the tire and wheel assemblies. Refer to *Tire and Wheel Removal and Installation* in the WCC Service Manual.
10. Adjust the rear wheel bearings. Refer to *Wheel Bearing Adjustment (Disc Brakes)* in the WCC Service Manual.
11. Install the axle shafts. Refer to *Axle Shaft Replacement (Spicer Dana S135 and S150 14 Inch)* in this supplement.
12. Lower the vehicle.



## Axle Replacement (American Axle 11 1/2 Inch)

### Removal Procedure

1. Raise the vehicle and place jack stands under the frame rails for support. Refer to *Lifting and Jacking the Vehicle* in the WCC Service Manual.
2. Place a suitable container under the rear axle housing to catch draining lubricant.
3. Remove the rear axle drain plug and let the lubricant drain into the container.
4. Disconnect the propeller shaft. Refer to *Three Piece Propeller Shaft Replacement* in the WCC Service Manual.
5. Remove the tire and wheel assemblies. Refer to *Tire and Wheel Removal and Installation* in the WCC Service Manual.
6. Remove the axle shafts. Refer to *Axle Shaft Replacement (All Models)* in the WCC Service Manual for 10 1/2 Inch axles or *Axle Shaft Replacement (American Axle 11 1/2 Inch)* in this supplement.
7. Remove the brake calipers. Refer to *Brake Caliper Replacement (Rear)* in the WCC Service Manual for 10 1/2 inch axles or *Brake Caliper Replacement (American Axle 11 1/2 Inch)* in this supplement.
8. Remove the hub and rotor assemblies. Refer to *Hub and Rotor Assembly* in the WCC Service Manual for 10 1/2 inch axles or *Hub and Rotor Assembly (American Axle 11 1/2 Inch)* in this supplement.
9. Remove the brake caliper mounting plates. Refer to *Brake Caliper Mounting Plate Replacement* in the WCC Service Manual.
10. Disconnect the rear brake hose. Refer to *Brake Hose Replacement – Rear* in the WCC Service Manual.
11. Disconnect the rear shock absorbers. Refer to *Shock Absorber Replacement* in the WCC Service Manual.
12. Disconnect the vent hose at the rear axle housing. Refer to *Vent Hose Replacement* in the WCC Service Manual.
13. Disconnect the rear stabilizer shaft. Refer to *Stabilizer Shaft Replacement* in the WCC Service Manual.
14. Support the rear axle assembly with a hydraulic jack.
15. Remove the U-bolts, nuts, washers, spring plates, and spacers from the rear springs. Refer to *Leaf Spring Replacement* in the WCC Service Manual.
16. Lower the jack and move the rear axle assembly out from under the vehicle.

**Important:** Transfer any remaining components, fittings, and hardware and brake lines over to the new rear axle assembly before installation.

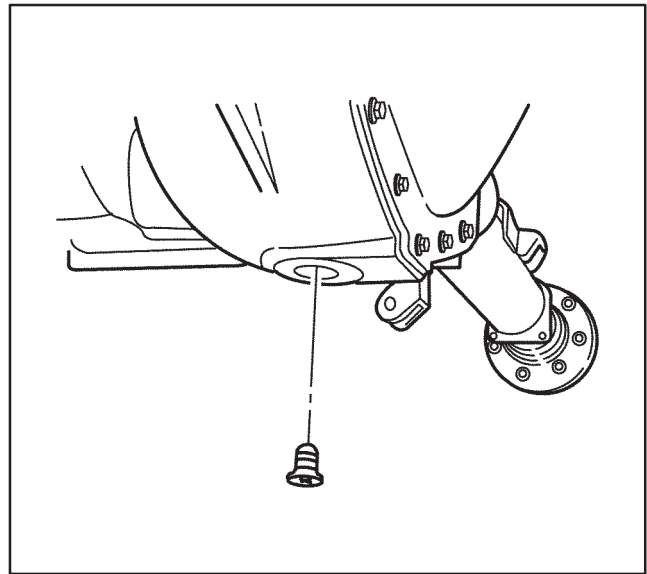

WRK42104

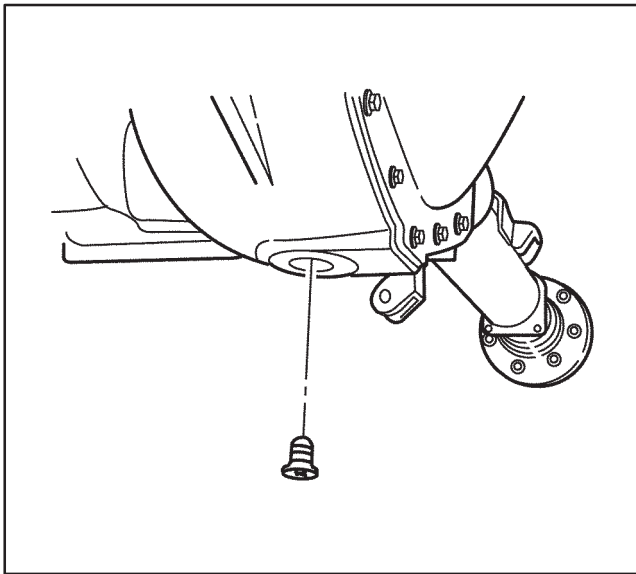

WRK42104

### Installation Procedure

1. Using a hydraulic jack, move the rear axle assembly into position under the vehicle.
2. Align the rear axle assembly with the rear springs.
3. Install the U-bolts, nuts, washers, spring plates, and spacers to the rear springs. Refer to *Leaf Spring Replacement* in the WCC Service Manual.
4. Remove the jack from the rear axle.
5. Connect the rear stabilizer shaft. Refer to *Stabilizer Shaft Replacement* in the WCC Service Manual.
6. Connect the vent hose at the rear axle housing. Refer to *Vent Hose Replacement* in the WCC Service Manual.
7. Connect the rear shock absorbers. Refer to *Shock Absorber Replacement* in the WCC Service Manual.
8. Connect the rear brake hose. Refer to *Brake Hose Replacement – Rear* in the WCC Service Manual.
9. Install the brake caliper mounting plates. Refer to *Brake Caliper Mounting Plate Replacement* in the WCC Service Manual.
10. Install the hub and rotor assemblies. Refer to *Hub and Rotor Assembly* in the WCC Service Manual for 10 1/2 inch axles or *Hub and Rotor Assembly (American Axle 11 1/2 Inch)* in this supplement.
11. Install the brake calipers. Refer to *Brake Caliper Replacement (Rear)* in the WCC Service Manual for 10 1/2 inch axles or *Brake Caliper Replacement (American Axle 11 1/2 Inch)* in this supplement.
12. Install the axle shafts. Refer to *Axle Shaft Replacement (All Models)* in the WCC Service Manual for 10 1/2 Inch axles or *Axle Shaft Replacement (American Axle 11 1/2 Inch)* in this supplement.
13. Install the tire and wheel assemblies. Refer to *Tire and Wheel Removal and Installation* in the WCC Service Manual.
14. Connect the propeller shaft. Refer to *Three Piece Propeller Shaft Replacement* in the WCC Service Manual.

**Notice:** Refer to *Fastener Notice* in Cautions and Notices in the WCC Service Manual.

15. Install the rear axle drain plug.

#### Tighten

- Tighten the rear axle drain plug to 24 N · m (18 lb ft) on 10 1/2 inch axles.
- Tighten the rear axle drain plug to 33 N · m (24 lb ft) on 11 1/2 inch axles.

16. Remove the rear axle fill plug and seal.
17. Fill the rear axle with the proper type and quantity of lubricant. Refer to *Lubrication Specifications and Fluid and Lubricant Recommendations* in the WCC Service Manual for 10 1/2 inch axles or in this supplement for 11 1/2 inch axles.

**Notice:** Refer to *Fastener Notice* in Cautions and Notices in the WCC Service Manual.

18. Install the rear axle fill plug and seal.

**Tighten**

- Tighten the rear axle fill plug to 24 N·m (18 lb ft) on 10 1/2 inch axles.
  - Tighten the rear axle fill plug to 33 N·m (24 lb ft) on 11 1/2 inch axles.
19. Remove the jack stands and lower the vehicle.

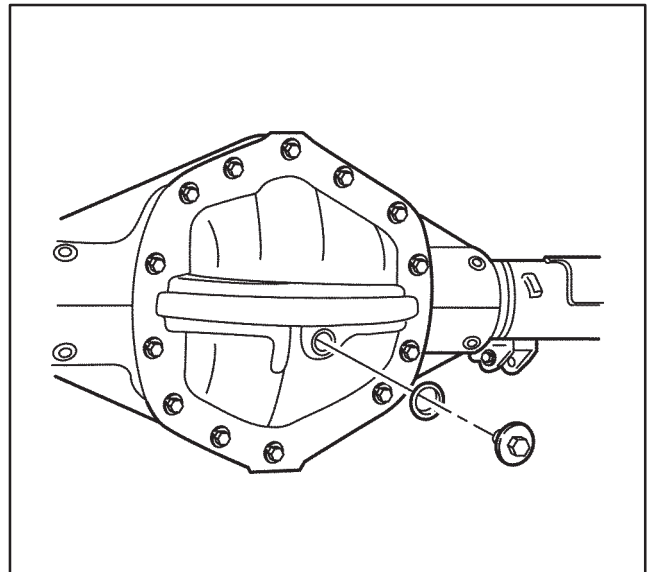

WRK42081

## Axle Replacement (Spicer Dana S135 and S150 14 Inch)

### Removal Procedure

1. Raise the vehicle and place jack stands under the frame rails for support. Refer to *Lifting and Jacking the Vehicle* in the WCC Service Manual.
2. Place a suitable container under the rear axle housing to catch draining lubricant.
3. Remove the rear axle drain plug and let the lubricant drain into the container.
4. Disconnect the propeller shaft. Refer to *Three Piece Propeller Shaft Replacement* in the WCC Service Manual.
5. Remove the tire and wheel assemblies. Refer to *Tire and Wheel Removal and Installation* in the WCC Service Manual.
6. Remove the axle shafts. Refer to *Axle Shaft Replacement (Spicer Dana S135 and S150 14 Inch)* in this supplement.
7. Remove the brake calipers. Refer to *Brake Caliper Replacement (Rear)* in the WCC Service Manual.
8. Remove the hub and rotor assemblies. Refer to *Hub and Bearing Replacement (Spicer Dana S135 and S150 14 Inch)* in this supplement.
9. Remove the brake caliper mounting plates. Refer to *Brake Caliper Mounting Plate Replacement* in the WCC Service Manual.
10. Disconnect the rear brake hose. Refer to *Brake Hose Replacement – Rear* in the WCC Service Manual.
11. Disconnect the rear shock absorbers. Refer to *Shock Absorber Replacement* in the WCC Service Manual.
12. Disconnect the rear stabilizer shaft. Refer to *Stabilizer Shaft Replacement* in the WCC Service Manual.

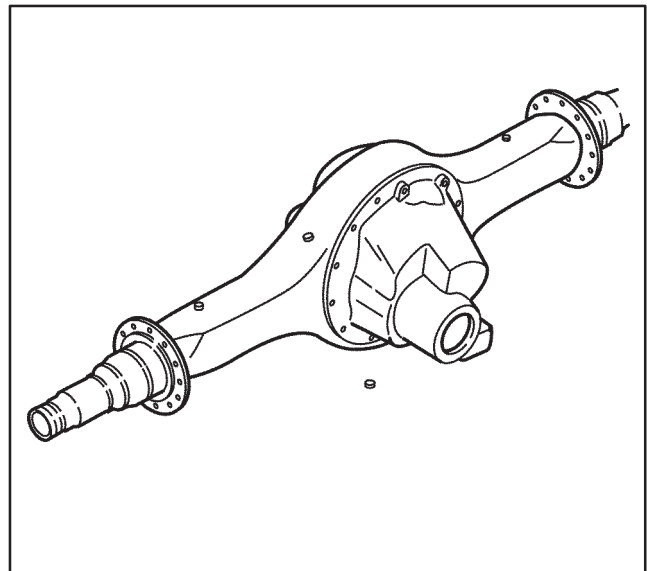

WRK42014

13. Support the rear axle assembly with a hydraulic transmission dolly with adapters.
14. Fasten a chain over the top of the axle and to both sides of the dolly.
15. Remove the U-bolts, nuts, washers, spring plates, and spacers from the rear springs. Refer to *Leaf Spring Replacement* in the WCC Service Manual.
16. Lower the dolly and move the rear axle assembly out from under the vehicle.

**Important:** Transfer any remaining components, fittings, and hardware and brake lines over to the new rear axle assembly before installation.

### **Installation Procedure**

1. Move the rear axle assembly into position under the vehicle.
2. Align the rear axle assembly with the rear springs.
3. Install the U-bolts, nuts, washers, spring plates, and spacers to the rear springs. Refer to *Leaf Spring Replacement* in the WCC Service Manual.
4. Remove the chain and dolly from the rear axle.
5. Connect the rear stabilizer shaft. Refer to *Stabilizer Shaft Replacement* in the WCC Service Manual.
6. Connect the rear shock absorbers. Refer to *Shock Absorber Replacement* in the WCC Service Manual.
7. Connect the rear brake hose. Refer to *Brake Hose Replacement – Rear* in the WCC Service Manual.
8. Install the brake caliper mounting plates. Refer to *Brake Caliper Mounting Plate Replacement* in the WCC Service Manual.
9. Install the hub and rotor assemblies. Refer to *Hub and Bearing Replacement (Spicer Dana S135 and S150 14 Inch)* in this supplement.
10. Install the brake calipers. Refer to *Brake Caliper Replacement (Rear)* in the WCC Service Manual.
11. Install the axle shafts. Refer to *Axle Shaft Replacement (Spicer Dana S135 and S150 14 Inch)* in this supplement.
12. Install the tire and wheel assemblies. Refer to *Tire and Wheel Removal and Installation* in the WCC Service Manual.
13. Connect the propeller shaft. Refer to *Three Piece Propeller Shaft Replacement* in the WCC Service Manual.
14. Fill the rear axle with lubricant. Refer to *Lubricant Change (Spicer Dana S135 and S150 14 Inch)* in this supplement.
15. Remove the jack stands and lower the vehicle.

## Cleaning and Inspection

### Cleaning

**Notice:** Alkaline type solutions may cause damage to machined surfaces and should not be used on any components.

### Cleaning

1. Parts should be cleaned with emulsion cleaners or petroleum base cleaning solvent.
2. Always clean the interior of rear axle housings prior to assembly.
3. Clean all sealing surfaces to prevent the loss of axle lubricant.

### Drying

**Caution:** *Never dry bearings by spinning them with compressed air. The bearings could come apart causing serious injury and may be damaged by a lack of lubrication.*

1. Use soft, clean, lint-free shop towels or rags to dry components after cleaning.
2. After drying, parts should be coated with a light coat of lubricant or rust inhibitor to prevent damage from corrosion.
3. If parts are to be stored for a prolonged period, they should be wrapped in wax paper.

### Inspection

Prior to reassembly, all parts should be inspected for excessive wear or damage. Replacement of excessively worn or damaged parts can prevent premature failure and costly downtime. Inspect all parts following these guidelines:

1. Inspect bearing surfaces for pitting, excessive wear, or evidence of overheating.
2. Inspect thrust washers for scoring and cracking.

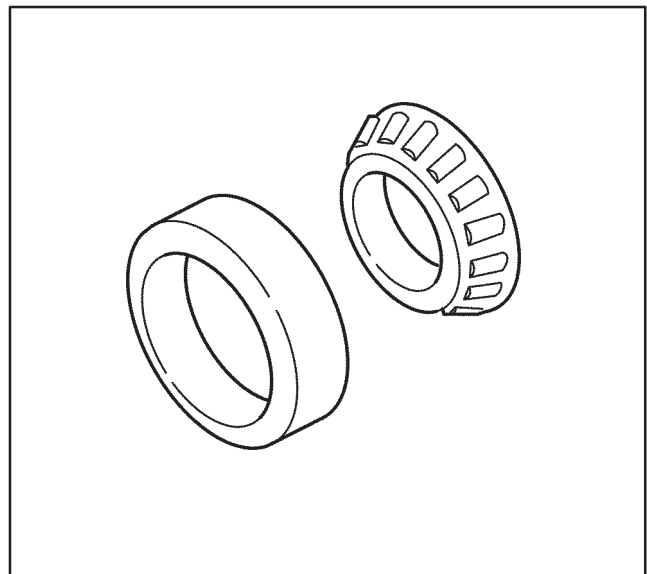

WRK42035

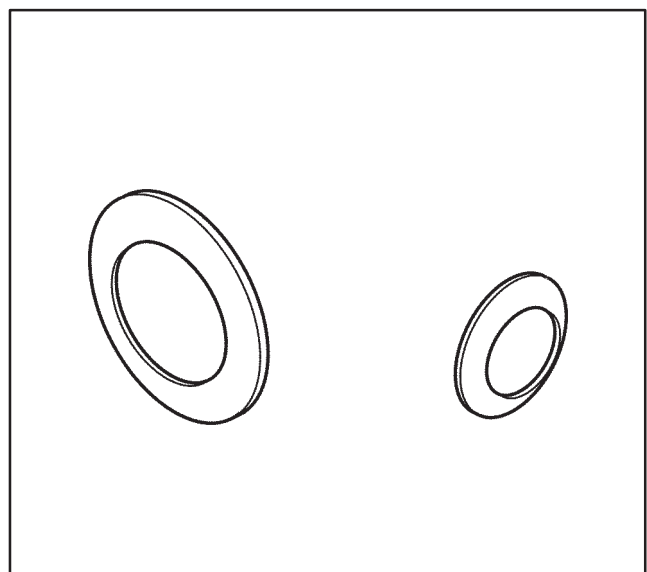

WRK42036

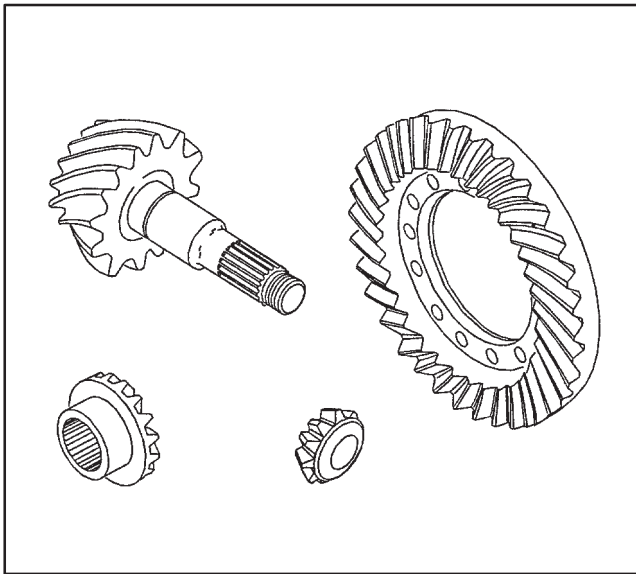

WRK42037

**Important:** Remember to replace gears in sets only.

3. Inspect gears for excessive wear or damage. Replace gears that are pitted, scored, broken, worn, or otherwise damaged.

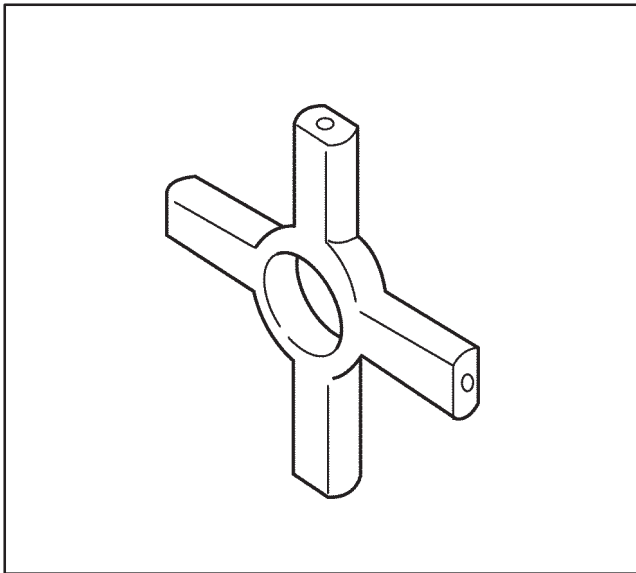

WRK42038

4. Inspect all shafts for nicks, scoring, or other damage.

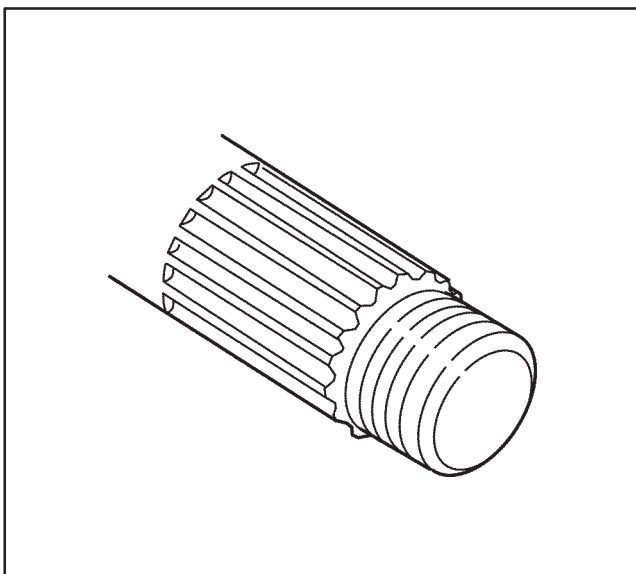

WRK42039

5. Inspect all splines for excessive wear, distortion from twisting, and cracking.

6. Inspect the rear axle housing for stripped threads, cracks and bending fatigue.

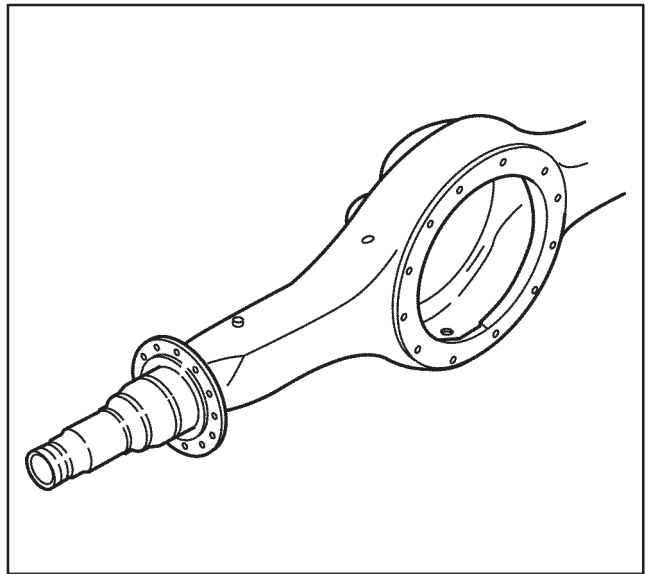

WRK42040

## Description and Operation

### Rear Axle Description

This supplement covers maintenance and rebuild procedures that pertain to the American Axle with an 11 1/2 inch ring gear and the Spicer Dana S135 and S150 Axle with a 14 inch ring gear, plus additional procedures for the American Axle with a 10 1/2 inch ring gear. The axles can be identified by the ring gear size in inches. For procedures on the other axles used by WCC, refer to the WCC Service Manual.

All of these rear axles are single reduction units and employ a hypoid gear and pinion set. They all use a two-bearing overhung pinion mounting. This arrangement eliminates the bearing cage, allowing a one-piece carrier.

### Gear Set Identification (Spicer Dana S135 and S150 14 Inch)

Spicer Dana ring and pinion sets are marked with the following information for easy identification:

(1) Spicer Trademark – Company logo and location of manufacturing facility

(2) Matched Set Number – Spicer ring gear and pinion are manufactured as matched sets. Both the pinion and the ring gear are marked with a corresponding number such as 260, which identifies them as a set.

**Important:** The numbers on the ring gear and pinion must match.

(3) Specified Backlash (etched on ring gear) – Specifies the backlash to be used anytime the differential is assembled.

(4) Manufacturer's Date – The date the gear set was manufactured.

(5) Spicer Trademark – Company logo and location of manufacturing facility.

(6) Heat Code – Type of heat treatment used during manufacturing.

(7) Part number – a typical example is 360GP104.

(8) Tooth Combination – Shows the number of teeth cut on the ring gear and the pinion. For example: 41-11 means 41 teeth on the ring gear and 11 teeth on the pinion. This example results in a ratio of 3.73 to 1.

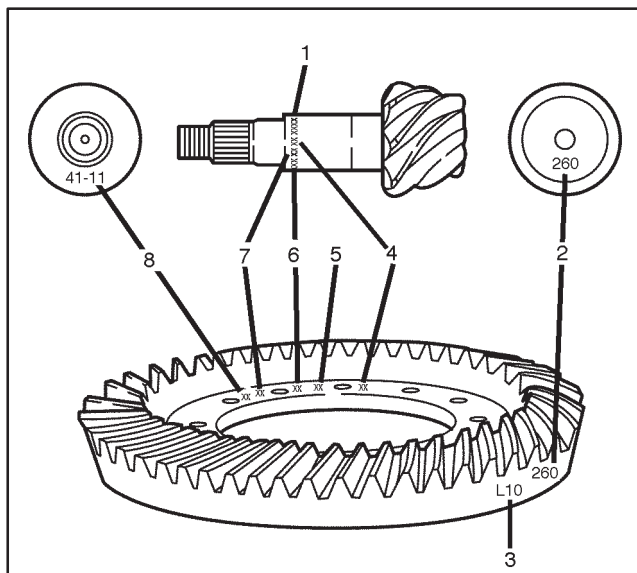

WRK42041



Special Tools and Equipment

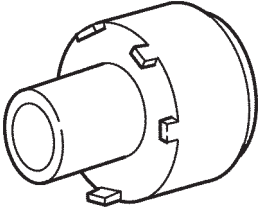

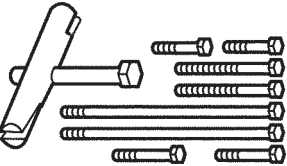
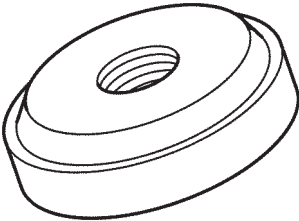
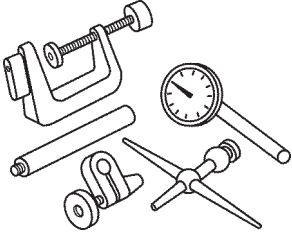

Illustration	Tool Number/ Description
 <p data-bbox="367 554 451 571">WRK42042</p>	<p data-bbox="488 359 748 415">J 2222-C Wheel Bearing Nut Wrench</p>
 <p data-bbox="367 905 451 921">WRK42043</p>	<p data-bbox="561 709 675 766">J 3453 Holding Bar</p>
 <p data-bbox="367 1257 451 1274">WRK42129</p>	<p data-bbox="509 1060 727 1117">J 5590 Pinion Bearing Installer</p>
 <p data-bbox="367 1610 451 1627">WRK42045</p>	<p data-bbox="570 1413 667 1470">J 7804-01 Puller</p>
 <p data-bbox="367 1959 451 1976">WRK42130</p>	<p data-bbox="496 1764 740 1841">J 7818 Outer Pinion Bearing Cup Installer</p>

Illustration	Tool Number/ Description
 <p data-bbox="1062 554 1146 571">WRK42131</p>	<p data-bbox="1235 359 1398 415">J 8001 Dial Indicator Set</p>
 <p data-bbox="1062 905 1146 921">WRK42046</p>	<p data-bbox="1252 709 1382 766">J 8092 Driver Handle</p>
 <p data-bbox="1062 1257 1146 1274">WRK42048</p>	<p data-bbox="1190 1060 1450 1138">J 8608 Outer Pinion Bearing Race Installer</p>
 <p data-bbox="1062 1610 1146 1627">WRK42049</p>	<p data-bbox="1182 1413 1458 1470">J 8614-01 Flange Holder and Remover</p>
 <p data-bbox="1062 1959 1146 1976">WRK42133</p>	<p data-bbox="1190 1764 1450 1820">J 21777-01 Pinion Setting Component</p>

(S1) 4-90 Rear Drive Axle

Driveline/Axle

Illustration	Tool Number/ Description
 WRK42132	J 21777-43 Stud Assembly Bolt
 WRK42051	J 22912-01 Split Plate Bearing Puller
 WRK42134	J 23409 Dial Indicator Extension
 WRK42055	J 24429 Side Bearing Nut Wrench
 WRK42136	J 25588 Side Bearing Shim Installer

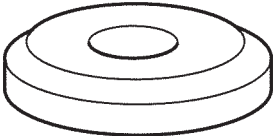
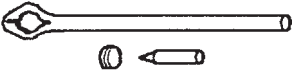
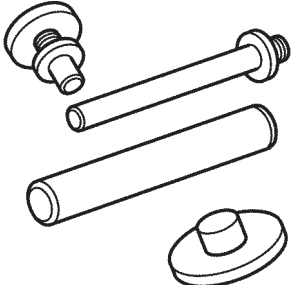
Illustration	Tool Number/ Description
 WRK42137	J 29710 Differential Side Bearing Installer
 WRK42138	J 29721 Universal Bearing Puller
 WRK42139	J 36135 Universal Bearing Cup Installer
 WRK42140	J 39707 Inner Pinion Bearing Cup Installer
 WRK42141	J 39708 Universal Driver Handle

**Driveline/Axle**

**Rear Drive Axle (S1) 4-91**

Illustration	Tool Number/ Description
 <p data-bbox="365 506 451 527">WRK42142</p>	<p data-bbox="511 310 727 367">J 41107 Oil Seal Installation Kit</p>
 <p data-bbox="365 856 451 877">WRK42143</p>	<p data-bbox="511 657 727 714">J 44412 Pinion Bearing Installer</p>
 <p data-bbox="365 1209 451 1230">WRK42144</p>	<p data-bbox="500 1010 738 1087">J 44414 Rear Axle Pinion Oil Seal Installer</p>
 <p data-bbox="365 1562 451 1583">WRK42145</p>	<p data-bbox="500 1362 738 1419">J 44416 Pinion Setting Adapter Kit</p>
 <p data-bbox="365 1913 451 1934">WRK42146</p>	<p data-bbox="500 1715 738 1793">J 44417 Rear Pinion Bearing Race Installer</p>

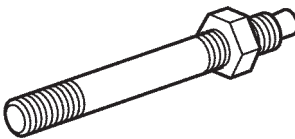
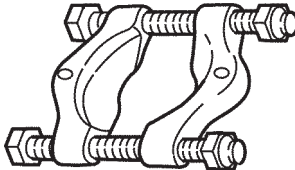
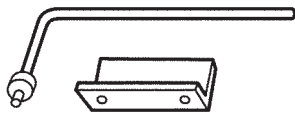
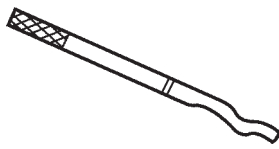
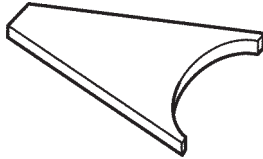
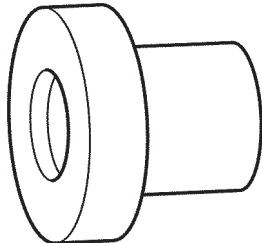
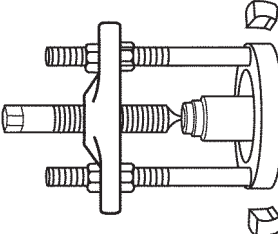
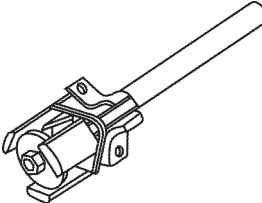
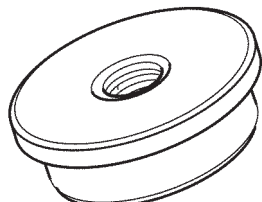
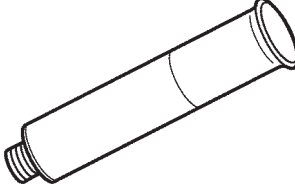
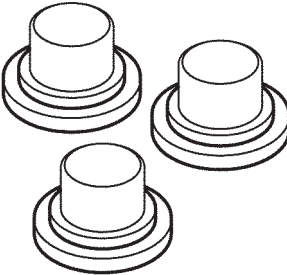
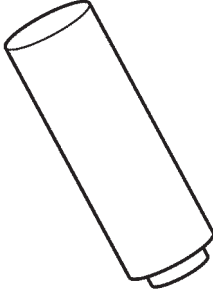
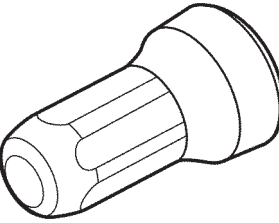
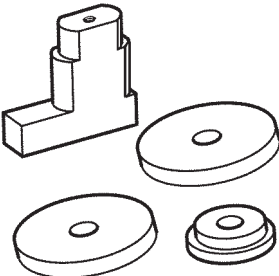
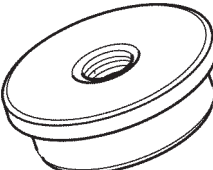
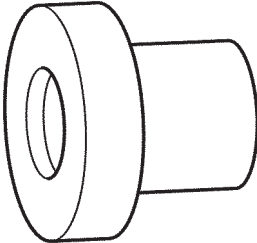
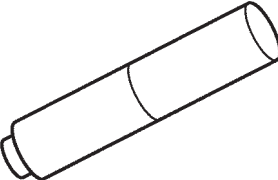
Illustration	Tool Number/ Description
 <p data-bbox="1062 506 1148 527">WRK42137</p>	<p data-bbox="1187 310 1451 388">J 44420 Differential Bearing and Hub Seal Installer</p>
 <p data-bbox="1062 856 1148 877">WRK42135</p>	<p data-bbox="1240 657 1391 714">J 44421 Pinion Remover</p>